



INSTALLATION GUIDE

REDI*ROCK®



The Redi-Rock logo is a registered trademark of Redi-Rock International, LLC of Charlevoix, MI USA.

The Redi-Rock name is a copyright of Redi-Rock International, LLC of Charlevoix, MI USA.

The information contained in the Installation Guide has been compiled by Redi-Rock International, LLC to document the performance of the Redi-Rock products contained therein. It is accurate to the best of our knowledge as of the date of its issue. Information included in the Installation Guide has been prepared in accordance with generally recognized engineering principles and practices. This information should not be used without first securing competent advice with respect to its suitability for any general or specific application. Final determination of the suitability of any design information and the appropriateness of this data for a given design purpose is the sole responsibility of the user.

No warranty of performance by Redi-Rock International, LLC or the DRM authors is expressed or implied by the publishing of the following Installation Guide.

Table of Contents

4 Installing Redi-Rock

34 Block Library

36 Block Textures

40 Isometric Block Drawings

Retaining, Freestanding, Accessories

64 Typical Construction Details





INSTALLING REDI-ROCK

1. PURPOSE

This manual is intended to serve as a guide for the proper installation and construction of a Redi-Rock® retaining wall. The recommendations and guidelines presented here are intended to supplement detailed construction documents, plans, and specifications for the project.

2. RESPONSIBILITIES

Redi-Rock supports a Total Quality Management approach to Quality Assurance and Quality Control (QA/QC) in the planning, design, manufacture, installation, and final acceptance of a Redi-Rock wall. This approach requires the responsible party at each stage of the project ensure that proper procedures are followed for their portion of the work. The responsible parties during the construction phase of a Redi-Rock wall include the Contractor, Engineer or Owner's Representative, and Redi-Rock licensed manufacturer. Their specific responsibilities for compliance are as follows:

CONTRACTOR

The Contractor is responsible for providing construction according to the contract documents, plans, and specifications for the project. The Contractor shall ensure that employees engaged in construction of the Redi-Rock wall understand and follow the project plans and specifications, are familiar with construction methods required, and have adequate safety training.

ENGINEER OR OWNER'S REPRESENTATIVE

The Engineer or Owner's Representative is responsible for construction review to assure that the project is being constructed according to the contract documents (plans and specifications). The representative shall fully understand the project plans and specifications and shall perform adequate field verification checks to ensure construction is in conformance with the project requirements. The presence of the Engineer or Owner's representative does not relieve the Contractor of their responsibilities for compliance with the project plans and specifications.

REDI-ROCK LICENSED MANUFACTURER

Redi-Rock blocks are produced by independently-owned licensed manufacturers. The manufacturer is responsible for the production and delivery of Redi-Rock units to the job site in accordance with published material quality, size tolerances, construction documents, plans, and specifications. The licensed manufacturer is responsible for adherence to any project specific QA/QC requirements for the production of precast concrete retaining wall units. Often, additional services—such as installation training classes—are available through the Redi-Rock manufacturer.

3. PRE-CONSTRUCTION CHECKLIST

Before you start construction of a Redi-Rock wall, take the time to complete necessary planning and preparation. This process will help ensure a safe, efficient, and quality installation. It will also help avoid costly mistakes.

SAFETY

Safety is of primary concern to Redi-Rock International. Redi-Rock walls must be installed in a safe manner. All local, state, and federal safety regulations must be followed. In addition, Redi-Rock International greatly encourages installers to set up company programs to help their people stay safe at work. These programs should address items such as: personal protective equipment, maintaining safe slopes and excavations, fall protection, rigging and lifting, and other safety precautions. Safety-training materials specific to your company can be found at www.osha.gov, by calling 1-800-321-OSHA (6742), or from your local government safety office.

ENGINEERING AND PERMITS

Obtain necessary engineering and permits for your project. Your local building department is an excellent resource to help determine the requirements for your project.

This installation guide is intended to supplement a detailed, site-specific wall design prepared for your project by a Professional Engineer. The construction documents for your project supersede any recommendations presented here.

REVIEW THE PROJECT PLANS

Take the time to review and understand the project plans and specifications. Make sure that the plans take into account current site, soil, and water conditions. Pay close attention to silty or clayey soils and ground water or surface water on the site as these can significantly increase the forces on the wall. A pre-construction meeting with the wall design engineer, construction inspector, wall contractor, and owner or representative is recommended.

CONSTRUCTION PLANNING

Develop a plan to coordinate construction activities on your site. Make sure your plan specifically addresses how to control surface water during construction.

UTILITY LOCATION

Make sure to have underground utilities located and marked on the ground before starting any construction. Call 8-1-1, go online to www.call811.com, or contact your local utility company to schedule utility marking for your project site.

□ MATERIAL STAGING

Store Redi-Rock blocks in a location close to the proposed wall. Blocks should be kept clean and mud free. Blocks should also be stored in a location which will minimize the amount of handling on the project site.

Store geogrid in a clean, dry location close to the proposed wall. Keep the geogrid covered and avoid exposure to direct sunlight.

Be careful where you stockpile excavation and backfill material. Do not stockpile material over buried utility pipes, cables, or near basement walls which could be damaged by the extra weight.

□ MATERIAL VERIFICATION

Material planned for use as drainage aggregate between and behind Redi-Rock blocks and structural backfill material proposed for use in the reinforced soil zone of mechanically stabilized earth walls must be inspected and verified to comply with requirements of the construction documents, plans, and specifications.

□ EQUIPMENT

Make sure you have the proper equipment to handle Redi-Rock blocks and install the wall. Redi-Rock blocks are quite large and heavy. Make sure excavators and other construction equipment are properly sized to handle the blocks safely. **(Figure 1)**

Hand-operated equipment should include, at a minimum: shovels, 2-foot (0.6-meter) level, 4-foot (1.2-meter) level, broom, hammer, tape measure, string, spray paint, laser level, pry or Burke bar, walk-behind vibratory plate compactor (capable of delivering a minimum of 2000 lb (8.9 kN) centrifugal force), and a 16-inch (406-millimeter) concrete cut-off saw. **(Figure 2)**

Personal protective equipment should include, at a minimum: appropriate clothing, steel toe boots with metatarsal protection, eye protection, hard hat, gloves, hearing protection, fall protection rigging, and other items as necessary to ensure a safe working environment.



Figure 1



Figure 2

4. SUBGRADE SOILS

Proper base preparation is a critical element in the construction of your retaining wall. Not only is it important to provide a stable foundation for the wall, but a properly prepared base will greatly increase the speed and efficiency of your wall installation. Proper base preparation starts with the subgrade soils.

Existing soils must be removed to the bottom of the leveling pad elevation for the retaining wall.

The base and back of excavation should expose fresh, undisturbed soil or rock. Remove all organic, unsuitable, and disturbed soils that “fall-in” along the base of the wall or the back of the excavation. Always provide safe excavations in accordance with OSHA requirements.

The subgrade soil (below the leveling pad) should be evaluated by the Engineer or Owner’s Representative to verify that it meets the design requirements and to determine its adequacy to support the retaining wall. Any unsuitable material shall be excavated and replaced as directed by the on-site representative and per the requirements of the contract drawings, plans, and specifications.

Subgrade soils must be compacted to a density as specified in the contract documents, plans, and specifications but not less than 90% maximum density at $\pm 2\%$ optimum moisture content as determined by a modified proctor test (ASTM D1557). **(Figures 3 and 4)**

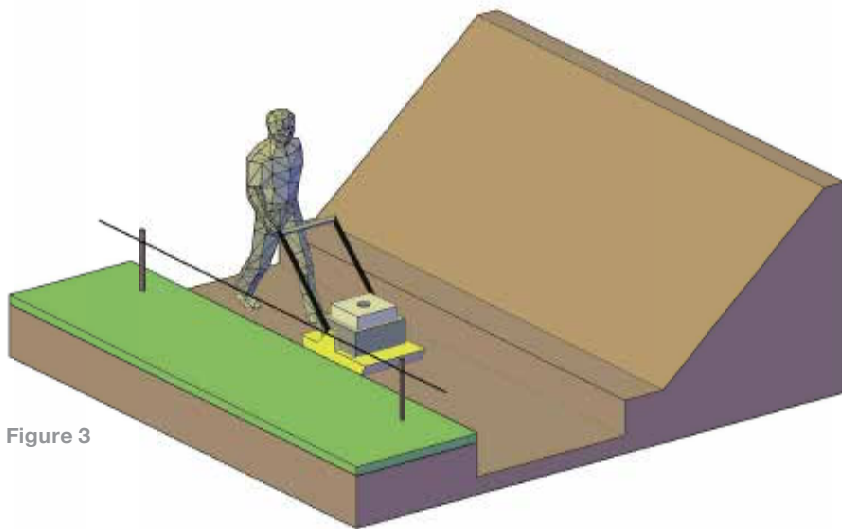

Figure 3

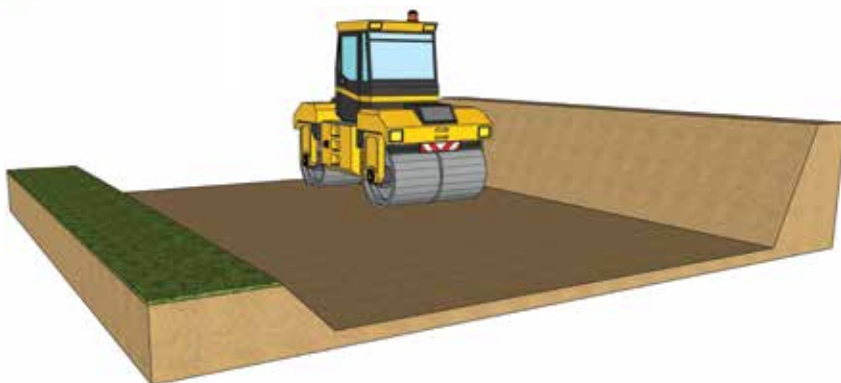

Figure 4

5. LEVELING PAD

Base preparation continues with proper leveling pad construction. Redi-Rock retaining walls can be designed with an open-graded crushed stone, dense-graded crushed stone (GAB), or concrete leveling pad which supports the bottom row of blocks. The choice of which type of leveling pad to use is made by the wall design engineer and depends on several factors including the bearing capacity of the native soil, location of the drain outlet, and conditions at the base of the wall.

Open-graded crushed stone is typically used in cases where the wall drain can outlet to daylight (by gravity) somewhere below the elevation of the bottom of the leveling pad. **(Figure 6A)** The material should be 1-inch (25-millimeter) diameter and smaller stone. A crushed stone meeting the gradation requirements of ASTM No. 57 with no material passing the No. 200 (74 μm) sieve is preferred. The leveling pad thickness shall be as designed by the wall design engineer. A minimum thickness of 6 inches (152 millimeters) or 12 inches (305 millimeters) is common. The leveling pad should extend at least 6 inches (152 millimeter) in front and 12 inches (305 millimeters) behind the bottom block. Make sure to check your construction documents for details.

Dense-graded crushed stone or graded aggregate base (GAB) material is typically used in cases where the wall drain can only outlet to daylight somewhere above the bottom of the leveling pad. **(Figure 6B)** The material should be dense-graded crushed stone with between 8 and 20% “fines” which will pass through a No. 200 (74 μm) sieve. The leveling pad thickness shall be as designed by the wall design engineer. Minimum dimensions are the same as those for an open-graded crushed stone leveling pad.

The leveling pad material should be placed and compacted to provide a uniform, level pad on which to construct the retaining wall. **(Figure 5)** Proper elevation can be established with a laser level or transit. You can also set two 20' (6 m) long grade (screed) pipes to the desired grade and screed the crushed stone material between the pipes.



Figure 5

Place the stone leveling pad in uniform loose lifts a maximum of 6 inches (152 millimeter) thick. Consolidate the stone with a minimum of three passes with a 24-inch (610-millimeter) wide walk-behind vibrating plate compactor capable of delivering at least 2000 pounds (8.9 kN) of centrifugal force. This should achieve 85% relative density of the stone determined in accordance with ASTM D-4253 and D-4254. In place density of the stone fill should be confirmed using ASTM D-6938. If you don't achieve a minimum of 85% relative density, place the stone in smaller lifts or apply more compaction effort until you do achieve desired density of the stone.

Unless specifically included in the design calculations, do NOT place a thin layer of sand between the leveling pad and bottom block. This layer will reduce the sliding resistance between the leveling pad and bottom block.

In some cases, the wall design requires the construction of a concrete leveling pad. **(Figures 6C and 6D)** Construct the leveling pad according to the detailed plans for your project.

Some designs require a shear key in the bottom of the footing and/or a lip in front of the Redi-Rock blocks. These items would be shown in the project plans.

If steel rebar is to be placed in the footing, secure the bars together with wire ties in the pattern shown in the construction documents. Use rebar supports to hold the rebar structure in the proper position in the footing.

Place wood formwork at the front and back of the concrete leveling pad or footing. The top of the formwork should be placed at the elevation of the top of the concrete footing so you can screed the top smooth in preparation for block placement. It is important that the top surface be smooth and level for full contact of the retaining wall blocks. Place concrete as specified in the wall design. Once the concrete has been allowed to cure to the minimum specified strength, place the bottom blocks and continue construction of the retaining wall.

Figure 6

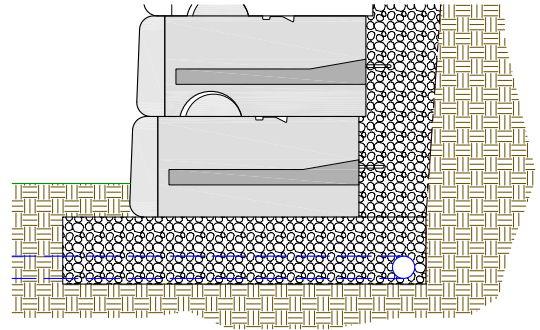

A. Open Graded Stone Leveling Pad

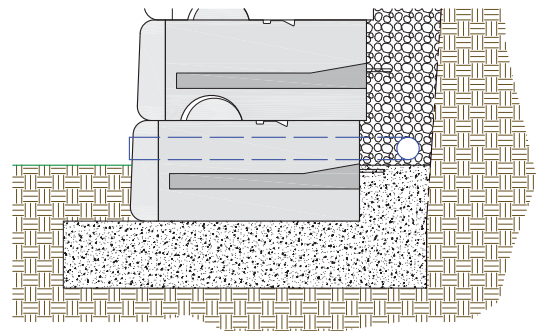

B. Dense Graded Stone Leveling Pad

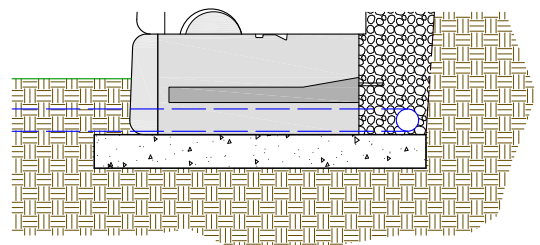

C. Lean Concrete Leveling Pad

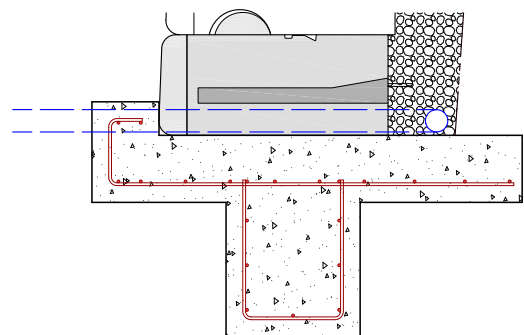

D. Reinforced Concrete Leveling Pad

6. SETTING THE BOTTOM ROW OF WALL BLOCKS

Redi-Rock blocks are typically delivered to the construction site using a flatbed trailer or boom truck. **(Figure 7)** Rubber tired backhoes, loaders, skid steers, or excavators are used to set the retaining wall blocks. **(Figure 8)** Make sure to use the proper sized equipment to handle the large blocks. All lifting chains, rigging, or slings must be OSHA compliant and safety rated for proper working loads.

Properly mark the location of the retaining wall. A string line or offset stakes are typically used to establish horizontal and vertical alignment. If offset stakes are used, the stakes should be placed at least 5 feet (1.5 meters) but no more than 10 feet (3 meters) in front of the face of the retaining wall. A stake should be provided at every elevation change and at a maximum of 50 feet (15 meters) apart.

Wall construction should start at a fixed point such as a building wall, 90° corner, or at the lowest elevation of the wall.

Place the blocks on the prepared leveling pad. Blocks shall be placed in full contact with the leveling pad and other immediately adjacent block units. **(Figure 9)** Block alignment should be established by lining up the “form line” where the face texture meets the steel form finished area at the top of the block, approximately 5 inches (127 millimeters) back from the front face. **(Figure 10)**

Check all blocks for level and alignment as they are placed. Small adjustments to the block location can be made with a large pry or Burke bar. Proper installation of the bottom block course is critical to maintaining the proper installation of all subsequent block courses within acceptable construction tolerance. It also makes installation of the upper rows of blocks much easier and more efficient.

Place and compact backfill in front of the bottom block course prior to placement of subsequent block courses or backfill. This will keep the blocks in place as drainage aggregate and backfill are placed and compacted.



Figure 7



Figure 8

Place an 18 inch x 12 inch (457 millimeter x 305 millimeter) piece of non-woven geotextile fabric in the vertical joint between the blocks to prevent the drainage aggregate and backfill material from migrating through the vertical joints between blocks. **(Figure 11)**

Place washed drainstone or open-graded crushed stone backfill between blocks and at least 12 inch (305 millimeter) behind the wall. A stone meeting the gradation requirements of ASTM No. 57 with no material passing the No. 200 (74 μ m) sieve is preferred. Place the stone in uniform loose lifts a maximum of 6 inches (157 millimeter) thick. Consolidate the stone with a minimum of three passes with a 24-inch (610 millimeter) wide, walk-behind, vibrating plate compactor capable of delivering at least 2000 lb (8.9 kN) of centrifugal force. **(Figure 12)** This should achieve 85% relative density of the stone determined in accordance with ASTM D-4253 and D-4254. In place density of the stone fill should be confirmed using ASTM D-6938. If you don't achieve a minimum of 85% relative density, place the stone in smaller lifts or apply more compaction effort until you do achieve desired density of the stone.

Place non-woven geotextile fabric between the drainstone and the remaining backfill material if specified.

Backfill behind the drainage aggregate with material as specified in the project construction documents. Place the lifts as specified, but not to exceed 9 inches (229 millimeter) maximum. Granular backfill shall be compacted to a minimum of 90% maximum density at $\pm 2\%$ optimum moisture content as determined by a modified proctor test (ASTM D1557). Use proper equipment to insure complete compaction of the backfill material. It may be necessary to wet or dry the backfill material, place the material in smaller lifts, and/or apply more compaction effort to reach 90% maximum density. Do not use any organic, topsoil, frozen, soft, wet, or loose soils when backfilling the wall.

Re-check all units for level and alignment and sweep the top of each course of blocks clean before starting construction of the next course.

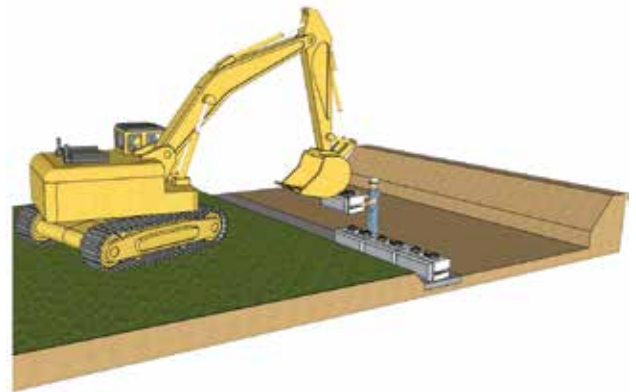

Figure 9

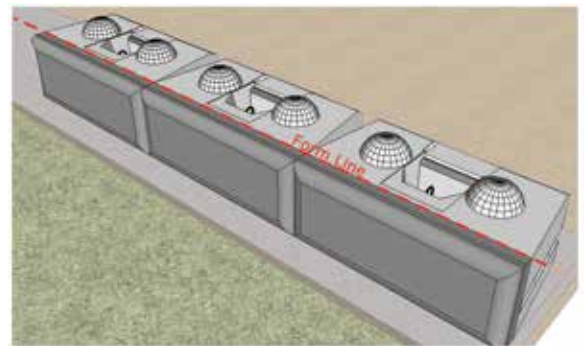

Figure 10

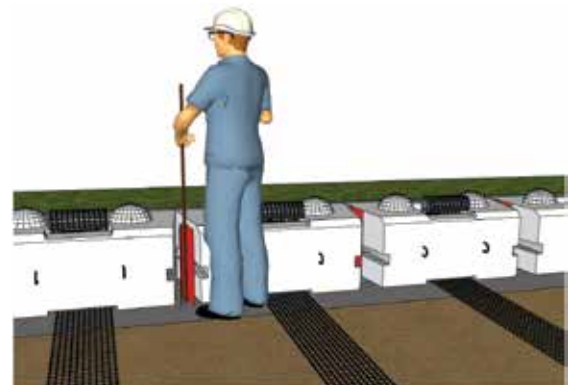

Figure 11



Figure 12

7. INSTALLING THE WALL DRAIN

A drain is placed behind the Redi-Rock wall blocks at the lowest elevation where the pipe can safely outlet to daylight. Drainage aggregate should be placed to the bottom of the drain as shown in the construction documents. A 4-inch (102 millimeter) perforated sock drain is commonly used for the drain pipe. Often the drain is encapsulated with drainage aggregate and wrapped with a non-woven geotextile fabric. The drain should run the entire length of the wall and needs to have proper outlets on the ends and at regularly spaced points along the wall. Solid pipe should be used for weep hole outlets through the face or under the retaining wall. **(Figure 13)**

Care needs to be taken during installation to avoid crushing or damaging the drain pipe or outlets.

8. SETTING UPPER ROWS OF WALL BLOCKS

Once the backfill is fully placed and compacted for the block course below, place the next row of blocks in a running bond configuration with the vertical joint of the lower block units centered under the mid-point of the block units above. If needed, a half block can be used at the end of every other row to maintain a running bond. **(Figure 14)**

Push the Redi-Rock blocks forward until the groove on the bottom of the block comes in full contact with the knobs on the blocks below. Adjacent blocks shall be placed with their front edges tightly abutted together.

Place non-woven geotextile fabric in the vertical joint between the blocks, and place and compact the drainage aggregate and backfill material the same way you did for the bottom row.

Never install more than one course of blocks without placing and compacting drainage aggregate and backfill to the full height of the block units. Placing multiple courses of blocks without backfill will prevent the proper placement and consolidation of the drainage aggregate between the blocks.

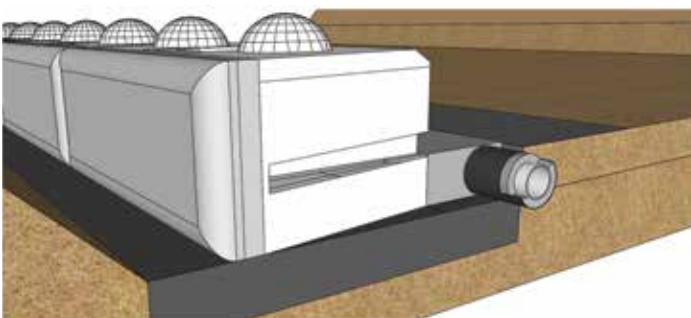

Figure 13

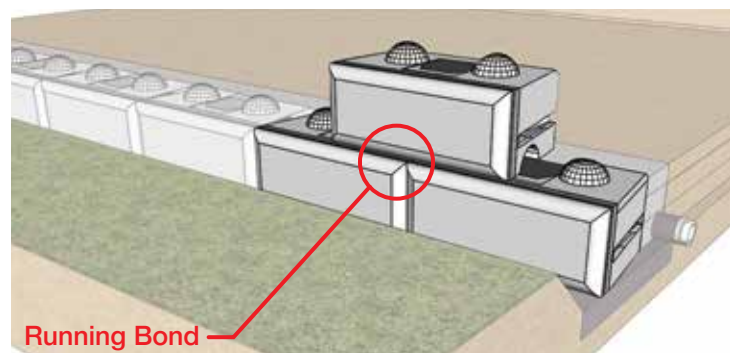

Figure 14

9. INSTALLING GEOGRID FOR MECHANICALLY STABILIZED EARTH WALLS

Redi-Rock blocks are designed to allow you to build relatively tall non-reinforced (or gravity) walls which use the weight of the blocks to provide stability. However, for some projects you may need to build even taller walls. In these cases, mechanically stabilized earth (MSE) retaining walls can be built with the Redi-Rock Positive Connection (PC) System.

The geogrid used in Redi-Rock PC System walls are 12-inch (305-millimeter) wide strips of PVC coated polyester geogrid that wrap through a vertical core slot cast into the block and extend full length into the reinforced soil zone on both the top and bottom of the block.

It is critical that you only use factory cut strips of Mirafi geogrid that are certified by TenCate Mirafi for width and strength. Field cutting strips of geogrid from larger rolls can significantly degrade the capacity of the wall system and is not allowed. Geogrid strips are only available through a Redi-Rock Manufacturer. (Figure 15)

Verify that you have the correct geogrid material and then cut the individual strips to the required length. The distance a geogrid strip must extend into the reinforced soil zone (design length) is measured from the back of the block to the end of the geogrid. Since the geogrid wraps through the block, the actual cut length of a given geogrid strip is two (2) times the design length plus enough additional geogrid to wrap through the block. For the Redi-Rock 28-inch (710-millimeter) PC blocks, the cut length is two (2) times the design length plus 3 feet (0.9 meters).

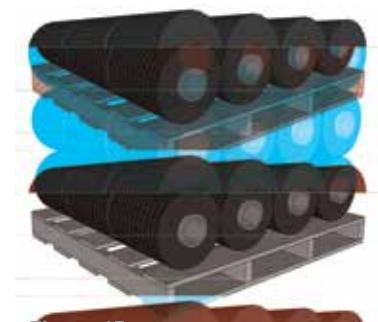

Figure 15

Inspect the Redi-Rock PC blocks for any concrete flashing or sharp edges in the slot and groove through the block. Remove any flashing and grind smooth any sharp edges which could damage the geogrid reinforcement.

Place the geogrid strip in the vertical core slot from the bottom of the block and pull approximately half of the length of the strip up through the core slot. Measure from the back of the block unit to the required design length and pin the bottom leg of the geogrid strip with staples, stakes, or other appropriate methods. Pull the geogrid strip tight to remove any slack, wrinkles, or folds. Secure the geogrid firmly in place by putting a pin through the geogrid and the steel lifting insert which is located in the recessed area on the top of the PC block (Figure 16) or placing drainage aggregate in the vertical core slot.

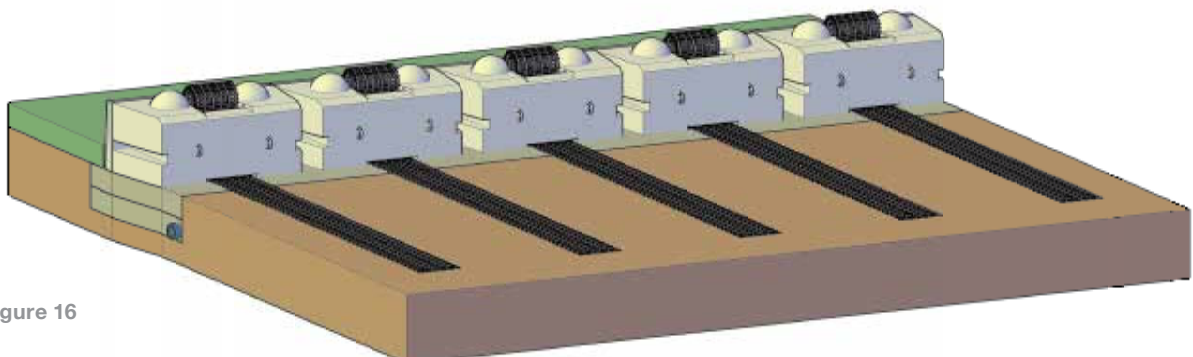

Figure 16

Place drainage aggregate between and behind the blocks. **(Figure 17)** Place the stone in uniform loose lifts as required in the project plans and specifications. Consolidate the stone between the blocks by hand tamping. Make sure to tamp stone into the ends of the groove on the bottom of the Redi-Rock PC blocks. Consolidate the stone behind the blocks with a minimum of three passes with a 24-inch (610-millimeter) wide walk-behind vibrating plate compactor capable of delivering at least 2000 lb (8.9 kN) of centrifugal force. Provide further compaction if needed to meet the density specified in the contract documents, but not less than 85% relative density of the stone determined in accordance with ASTM D-4253 and D-4254.

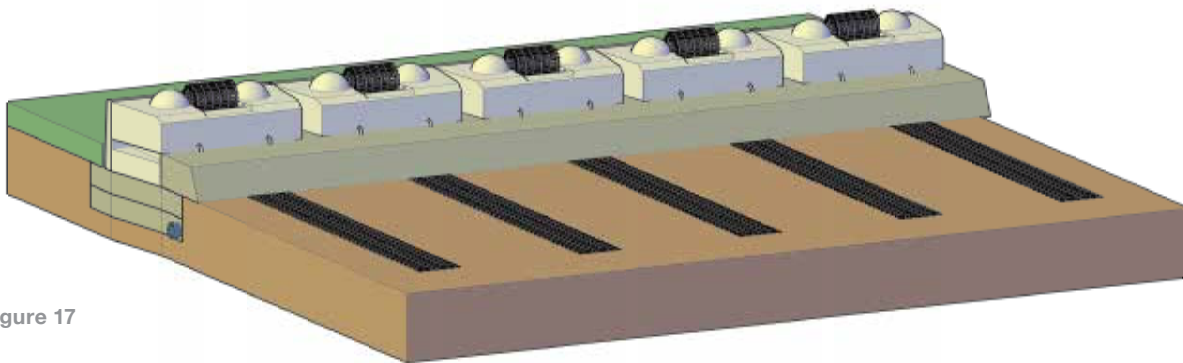

Figure 17

Place a strip of non-woven geotextile fabric between the drainage aggregate and the reinforced soil zone if specified.

Place the reinforced soil zone material in uniform loose lifts as required in the project plans and specifications. Reinforced soil zone material must be compacted to a density as specified in the contract documents, plans, and specifications but not less than 90% maximum density as determined by a modified proctor test (ASTM D1557).

Begin compaction at the back of the wall blocks and proceed to the embedded end of the geogrid strip using care to maintain the reinforcement strip in a level, taut condition oriented perpendicular to the back of the block unit to which it is attached.

Use hand operated compaction equipment within 3 feet (1 meter) of the back of the PC blocks. Heavier equipment can be used beyond 3 feet (1 meter) away from the PC blocks. Tracked construction equipment must not be operated directly on the geogrid strip reinforcement. A minimum fill thickness of 6 inches (150 millimeter) is required for the operation of tracked vehicles over the geogrid strips. Turning of tracked vehicles should be kept to a minimum to prevent displacement of the fill and the geogrid strips. Rubber-tired vehicles may pass over the geogrid strips at a slow speed of less than 5 mph (8 km/hr). Sudden braking and sharp turning should be avoided.

After placing and properly compacting backfill to the elevation of the geogrid strip at the top of the block, extend the top leg of the geogrid strip to the design length required. Pull the geogrid strip tight to remove any slack, wrinkles, or folds. **(Figure 18)** Pin the top leg of the geogrid strip with staples, stakes, or other appropriate methods to hold it in place and keep the geogrid strip taut.

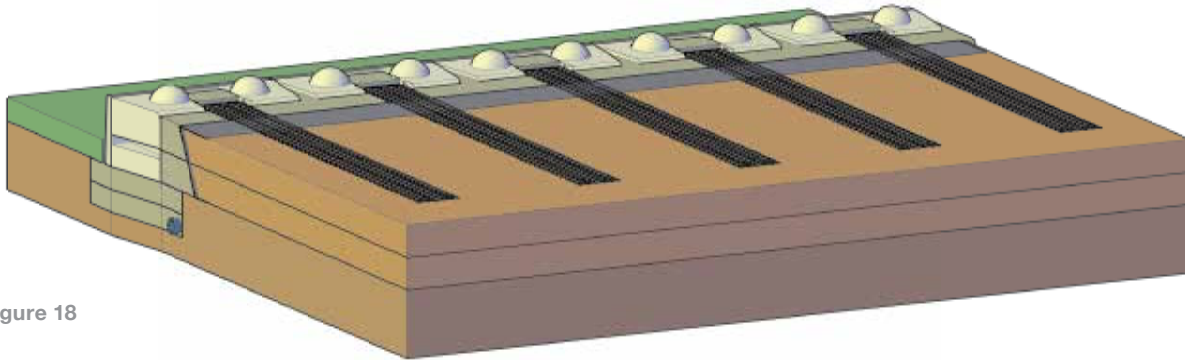

Figure 18

Fill the center slot in the PC blocks with drainage aggregate. Be careful to keep the grid flat against the back of the slot in the PC block and prevent any stone from lodging between the geogrid and the concrete block. Fill the vertical core slot completely with drainage aggregate. Consolidate the drainage aggregate by hand tamping. Use a broom to sweep clean the top of the blocks. Do not operate a walk behind vibratory plate compactor on top of the Redi-Rock PC blocks.

Place retained soil immediately between the end of the reinforced soil zone (identified as the embedded end of the geogrid reinforcement strips) and the back of the excavation. Compact retained soil to a density as specified in the contract documents, plans, and specifications but not less than 90% maximum density at $\pm 2\%$ optimum moisture content as determined by a modified proctor test (ASTM D1557). Maximum differential elevation between the reinforced fill and the retained soil fill should never exceed 18 inches (457 millimeters).

Continue construction in a similar fashion to the top of the wall. **(Figure 19)**

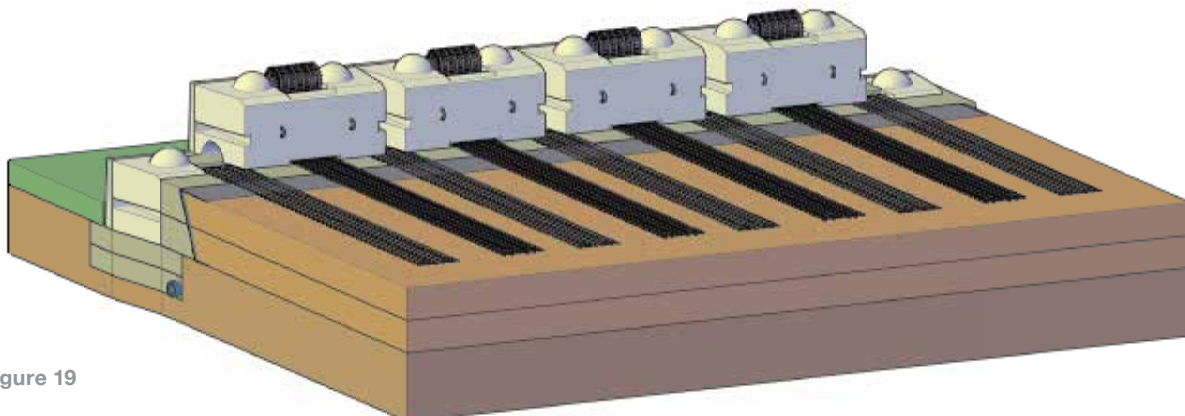

Figure 19

10. XL HOLLOW-CORE RETAINING BLOCKS

The greater width of XL blocks allows gravity walls to be built to greater height, while the greater individual block heights means that each block creates more area of wall face. XL block retaining wall installation generally follows the procedures of other Redi-Rock products, with a few differences.

Following the general procedures of sections 1 to 9, prepare the subgrade soils and place the leveling pad. The required leveling pad thickness will depend on the design by the wall design engineer, but will generally be a minimum of 12 inches (305 mm) thick.

Use appropriately-rated rigging fastened to the three lift hooks (one in the middle and two in the back of the blocks) and suitable heavy equipment to lift blocks into place. Place the first row of blocks to the correct line and grade. Just as with other Redi-Rock products, extra attention to ensure the first row of blocks is level and installed to the correct line and grade will save effort later as the installation proceeds.

Place two 18-inch (457 mm) by 18-inch (457 mm) pieces of non-woven geotextile fabric in each vertical joint between blocks – one on the upper half of the joint and one in the lower, wedge-shaped portion of the joint - to prevent the drainage aggregate and backfill material from migrating through the vertical joints at the blocks' face. Place washed drainstone or open-graded crushed stone backfill into the hollow cores of the blocks and between blocks in lifts of no more than 9 inches (230 mm) deep. Compact each lift by tamping until no further consolidation occurs with a soil tamper or other similar method. Strike off the top and sweep the upper surface of the blocks so the next row will sit cleanly on the lower row.

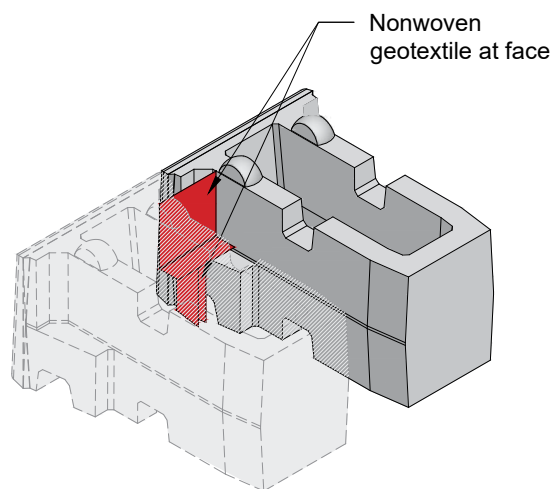

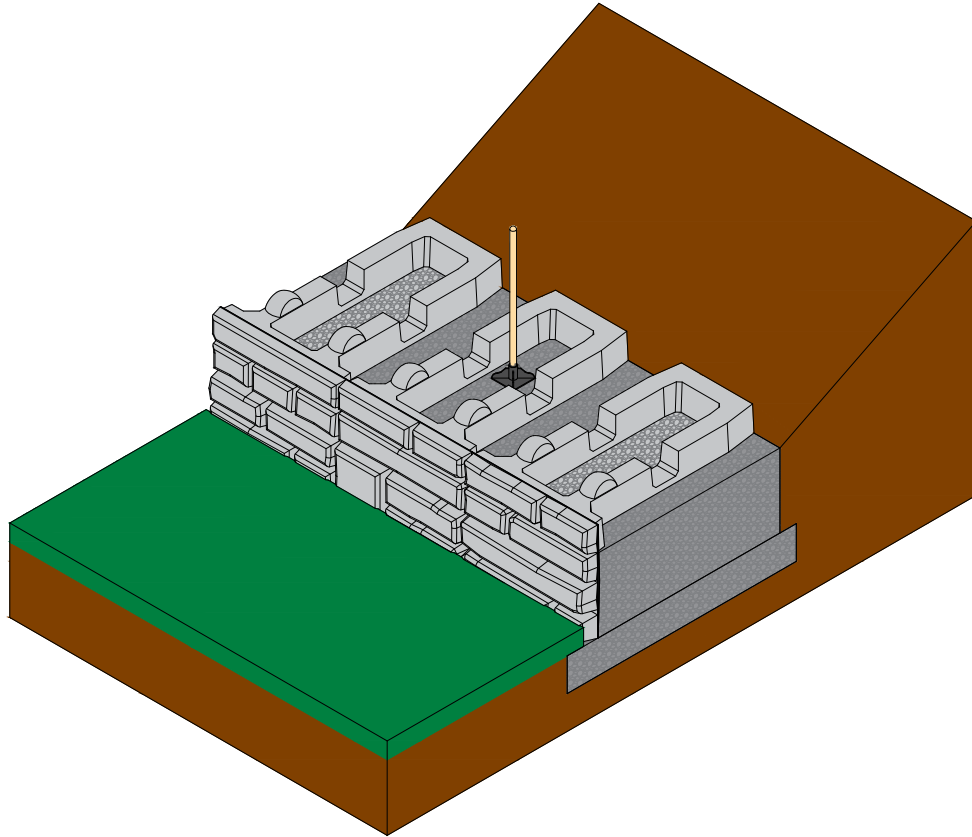

Due to the high percentage of open-graded stone within and between blocks, a drainage course behind the blocks is not required, but may be desirable to ease compaction of backfill and improve drainage. Place a layer of nonwoven geotextile fabric between the back of blocks (or drainstone layer, if used) and retained backfill.

Place and compact backfill as described above and repeat as necessary to reach the required height. Finish the top of wall with one or more rows of 18-inch (457 mm) high retaining blocks or freestanding blocks.

11. SPECIAL FEATURES

Some walls require special features such as curves, corners, top of wall details, details for elevated groundwater applications, and other details. Refer to the construction documents, plans, and specifications for details to construct these features. Additional general reference construction details are available on the Redi-Rock website, redi-rock.com.



Figure 21



Figure 22



Figure 23

12. IMPORTANT NOTES

Best practice dictates that wall construction should continue without interruption or delays. This will help expedite construction and minimize the time the excavation is open.

The construction site should be graded and maintained to direct surface water runoff away from the retaining wall throughout the entire construction process.

Do not exceed the allowable construction tolerances specified in the contract documents, plans, and specifications. At no time should tolerances at the wall face exceed 1° vertically and 1" in 10' (1:120) horizontally.

Immediately report the following site conditions, if encountered, to the Engineer or Owner's representative to determine the corrective action needed:

- Any observed groundwater seepage.
- Surface water run-off directed toward the retaining wall during construction.
- Erosion or scour of material near the wall.
- Ponded water near the wall.
- Wet, soft, or easily compressible soils in the foundation zone.
- Existing rock that differs in location from that shown on the project plans or rock located above the elevation of the bottom of the leveling pad.
- Existing or proposed toe or crest slopes that differ from typical cross-sections shown in the project plans.
- Any other items not specifically mentioned which raise questions or cause concerns during wall construction.

Immediately implement any corrective action before resuming wall construction.

13. FREESTANDING WALLS

Redi-Rock freestanding wall blocks have facing texture on two or three sides. They are used in applications where two or three sides of the wall are visible. Freestanding blocks can be installed as “stand alone” walls, such as perimeter walls or fences. They can also be designed and installed as the finishing top courses on a Redi-Rock retaining wall.

Freestanding wall installation is similar to that for Redi-Rock retaining walls. The main exception is that there is typically no backfill material behind the freestanding walls. Even though there is no backfill acting on the walls, freestanding walls need to be properly engineered. They require adequate stability at the base of the wall and they need to resist any applied forces such as wind loads or forces from railings or fences.

If you are building a “stand alone” freestanding wall, prepare the subgrade soils and leveling pad as described previously. Place bottom blocks on the leveling pad. A 6 inch (152 millimeter) minimum bury on the bottom block is typical. Extra bury may be required for some projects. Middle and top blocks are placed directly on top of the bottom blocks with no batter.

If you are building a freestanding wall on the top of a Redi-Rock retaining wall, end the last row of retaining wall blocks with a middle block. The size of the knob on top of the last row of retaining wall blocks will establish the setback for the first row of freestanding blocks. Retaining blocks with a 10-inch (254-millimeter) diameter knob will produce a 2 7/8 inch (73 millimeter) setback between the retaining block and the first freestanding block. If the retaining blocks have a 7 ½ inch (190 millimeter) diameter knob, the setback between the retaining block and the first freestanding block will be 1 5/8 inches (41 millimeters). Be sure to contact your local Redi-Rock manufacturer to determine availability of blocks with different knob sizes.

Begin and end freestanding walls with full or half Corner blocks.

Freestanding walls are installed plumb with no batter.



Figure 24

Variable radius freestanding blocks with a 4 inch x 12 inch (102 millimeter x 305 millimeter) pocket in one or two ends of the block are used to make curved walls. Field cut the relatively thin face texture on the ends of the variable radius blocks as needed to make the desired radius for your wall. **(Figure 24)**

Colored foam “Backer Rod” can be used to fill any small gaps which may occur between the blocks when installing walls. Backer rods can be purchased from concrete supply centers. Call your local Redi-Rock manufacturer for help locating foam backer rods for your project.

14. MAGIC BLOCK HOLLOW-CORE FREESTANDING WALLS

Redi-Rock Magic Block freestanding hollow-core units are stacked, similar to other Redi-Rock freestanding blocks, but then filled with concrete. Freestanding Hollow-Core Blocks work well for freestanding barriers, and can also be utilized for cantilever retaining walls.

CANTILEVERED WALLS

For many applications, the Freestanding Hollow-Core Blocks will be supported by a reinforced concrete footing. Prior to placing the footing, layout the wall to determine the locations of the open cores in the staggered rows of hollow-core units. This will help determine where rebar should be placed in the footing. When determining vertical rebar placement, consider the equipment that will be used to set the block to help avoid conflicts. Number and size of rebar will depend upon the engineer's structural design.

Construct the footing on a competent subgrade per the design drawings. Once the footing has cured, use a stringline to mark the alignment of the blocks (usually the inside of the block). Begin setting blocks. A scissors-type clamp works well. **(Figure 25)** Alternatively, straps looped around the interior ribs can be used, as well.



Figure 25

Corners can be constructed in the wall using hollow-core corner blocks. These blocks have texture on three sides. For a tight fit between blocks, the texture on the corner block can be trimmed by 2 or 3 inches where it abuts the adjacent block. If the design requires continuous rebar, cut a section out of the side of the corner block aligned with the hollow core of the adjacent block. **(Figure 26)**

Place horizontal rebar in the blocks, supported in the grooves on the interior structural ribs. Place the vertical rebar, lapping and tying, as required.

Stack the next row of block, making sure to carefully align the blocks and staggering the joints to create a running bond. We recommend stacking no more than three courses of block without filling the core.

Prior to infilling the wall, we suggest grouting the joints between blocks with non-shrink standard grout. This helps prevent leakage during infilling, and provides an aesthetic element.

Infill the hollow core of the wall with ready-mix concrete meeting the requirements of the design. Place the concrete carefully to prevent misalignment of the rebar. While filling, use an internal concrete vibrator to ensure consolidation and eliminate voids.



Figure 26

COPING

Magic Block Freestanding Hollow-Core Blocks can be placed on Redi-Rock PC-series walls to create a free-standing coping. The connection uses a No. 3 rebar hook to tie the coping to the upper PC blocks.

Install a No. 3 rebar hook through the lifting hook in each PC block and let the hook lay on the shear knob.

Install PC geogrid strips, if required. Fill the PC core with stone to the recess area. Place plastic sheeting over the geogrid exposed in the PC core.

Set the Freestanding Hollow-Core Blocks in place on the PC blocks.

Install the horizontal and vertical reinforcing steel, as required by the design. Pull the rebar hooks up into the Freestanding Hollow-Core Blocks core and engage with the horizontal rebar. Fill the hollow cores with concrete.

(Figures 27 & 28)



Figure 27

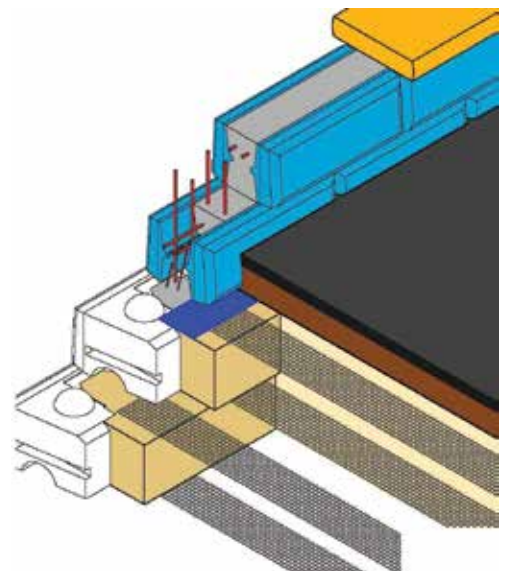

Figure 28

WATER CONTROL APPLICATIONS

A few additional details can be incorporated into Freestanding Hollow-Core walls to improve their water-tightness for flood control and other water-related applications. **(Figure 29)**

Prior to constructing the footing, perform any subgrade preparation, soil improvements, and/or drainage installation as required by the design.

Install an appropriate waterstop at the joint between the footing and the bottom of the wall, following the waterstop manufacturer's recommendations.

When using a ribbed center bulb strip, install it prior to pouring concrete for the footing such that it will be half embedded in the footing. Commonly, it will require attaching to the footing rebar with wire ties.

A bentonite/butyl rubber expandable waterstop can be installed on top of the footing prior to installing the first row of blocks. Be sure to protect the strip from damage and keep it clean.

A keyway can be cast into the footing if required by the design.

Avoid block-to-block joints where structural ribs from adjacent blocks will be in contact, as this will result in a joint with little, if any, cast-in-place concrete available to resist water flow. If necessary, remove one of the offending ribs with a concrete saw.

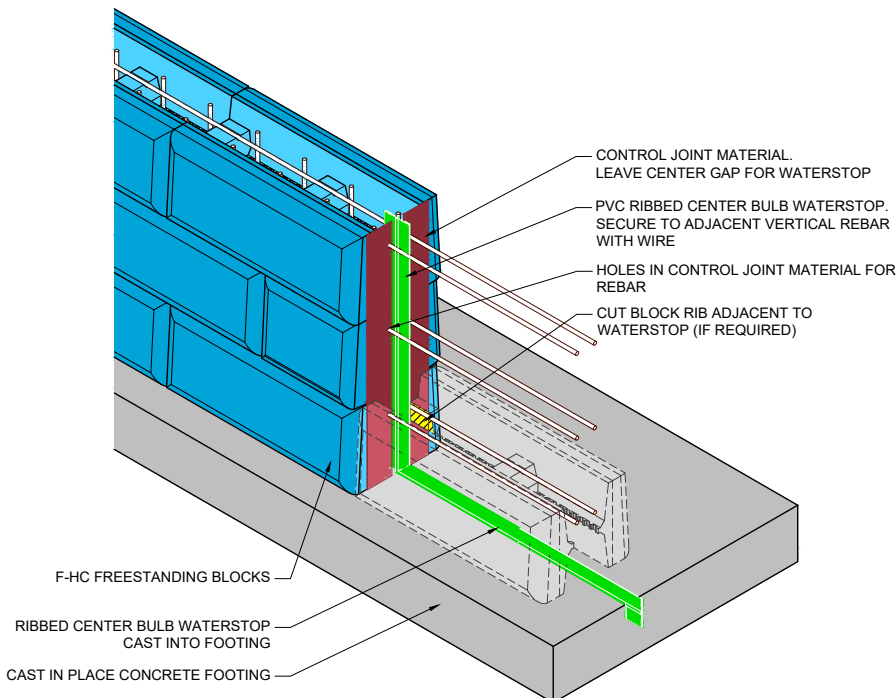

Figure 29

When placing concrete, extra care should be taken to fully consolidate the concrete to eliminate voids which could become conduits for water. Integral crystalline waterproofing admixtures are available that can reduce permeability and seal small cracks. Additional measures, such as sealing exposed joints with non-shrink grout and/or mastic and casting a slab against the wall can also be used to reduce water penetration. Foundation waterproofing experts should be consulted to select and assist with the installation of any performance improvement measures.

15. CAP INSTALLATION

Cap or step blocks are commonly used on top of freestanding walls to provide a finished look. **(Figure 30)**

Mark the center of the freestanding blocks to monitor the correct running bond spacing.

Secure the cap with construction adhesive, polyurethane sealant, or mortar. If construction adhesive is used, it should meet the requirements of ASTM D3498 and C557 and HUD/FHA Use of Materials Bulletin #60. Two examples are Titebond Heavy Duty Construction Adhesive by Franklin International or PL Premium Construction Adhesive. If polyurethane sealant is used, it should be one-component, highly-flexible, non-priming, gun-grade, high-performance elastomeric polyurethane sealant with movement of $\pm 25\%$ per ASTM C719, tensile strength greater than 200 psi (1.4 MPa) per ASTM D412, and adhesion to peel on concrete greater than 20 PLI per ASTM C794.

Adhesive or sealants should be applied in 1.5 inch (38 millimeter) diameter round “Hershey Kiss” shaped dollops located in two rows at the top of the freestanding blocks at 8 inches (203 millimeter) on center.

Caps can be cut as needed for proper alignment. If desired, grout the joints between cap blocks after installation with a non-shrink grout.



Figure 30

16. FORCE PROTECTION WALLS

Install a threaded termination end on the end of the cable. Electroline M Series terminations manufactured by *Esmet, Inc.* work well.

Thread cable with a termination end through all the blocks. It is important that the cable is placed in each course of blocks prior to placing the next course.

Pull the cable through the block on the far end of the wall until approximately 2 inches (51 millimeters) of threads protrude beyond the end of the blocks. The exposed threads will provide room to place for a 5/8 inch x 6 inch x 9 inch (16 millimeter x 152 millimeter x 229 millimeter) steel plate over the exposed threads and start the nut.

Mark and cut the cable at the starting end of the wall so that 4 inches (102 millimeter) of cable protrudes beyond the block, providing room a 5/8 inch x 6 inch x 9 inch (16 millimeter x 152 millimeter x 229 millimeter) steel plate and ferrule termination fitting.

After the cable has been cut, slide the entire cable several feet (meters) towards the ferrule end so that you will have room to work. Install a steel plate and ferrule termination end on the cable.

Pull the cable snug so that the ferrule is against the steel plate. There will be 2 inches (51 millimeters) of thread exposed at the far end of the wall which has the termination end on the cable.

Place the steel plate over the threads and start the nut. The nut can be tightened to the desired tension.

Force Protection Coping With J-Bolts and Post-Tensioned Cable

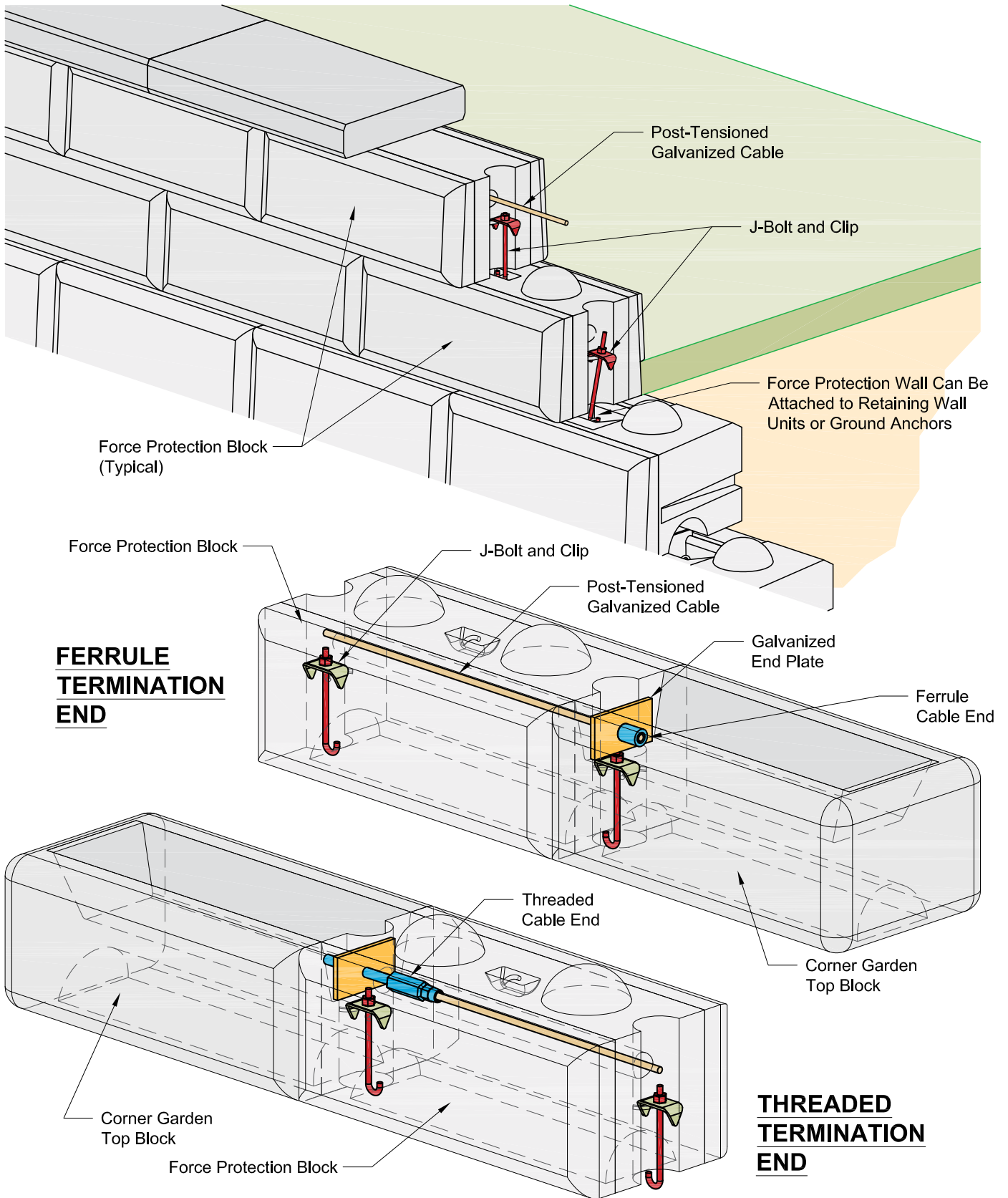

- This drawing is for reference only.
- **Final designs for construction must be prepared by a registered Professional Engineer** using the actual conditions of the proposed site.
- **Final wall design must address both internal and external drainage and shall be evaluated by the Professional Engineer who is responsible for the wall design.**

Force Protection Coping With J-Bolts

- This detail can be installed with either a single or multiple rows of Force Protection blocks.
- J-Bolts and clips are used to connect the top row of retaining blocks and all Force Protection blocks together.
- J-Bolt installation is not intended for traffic impact loads.
- Force Protection blocks can be attached to retaining wall blocks or ground anchors.

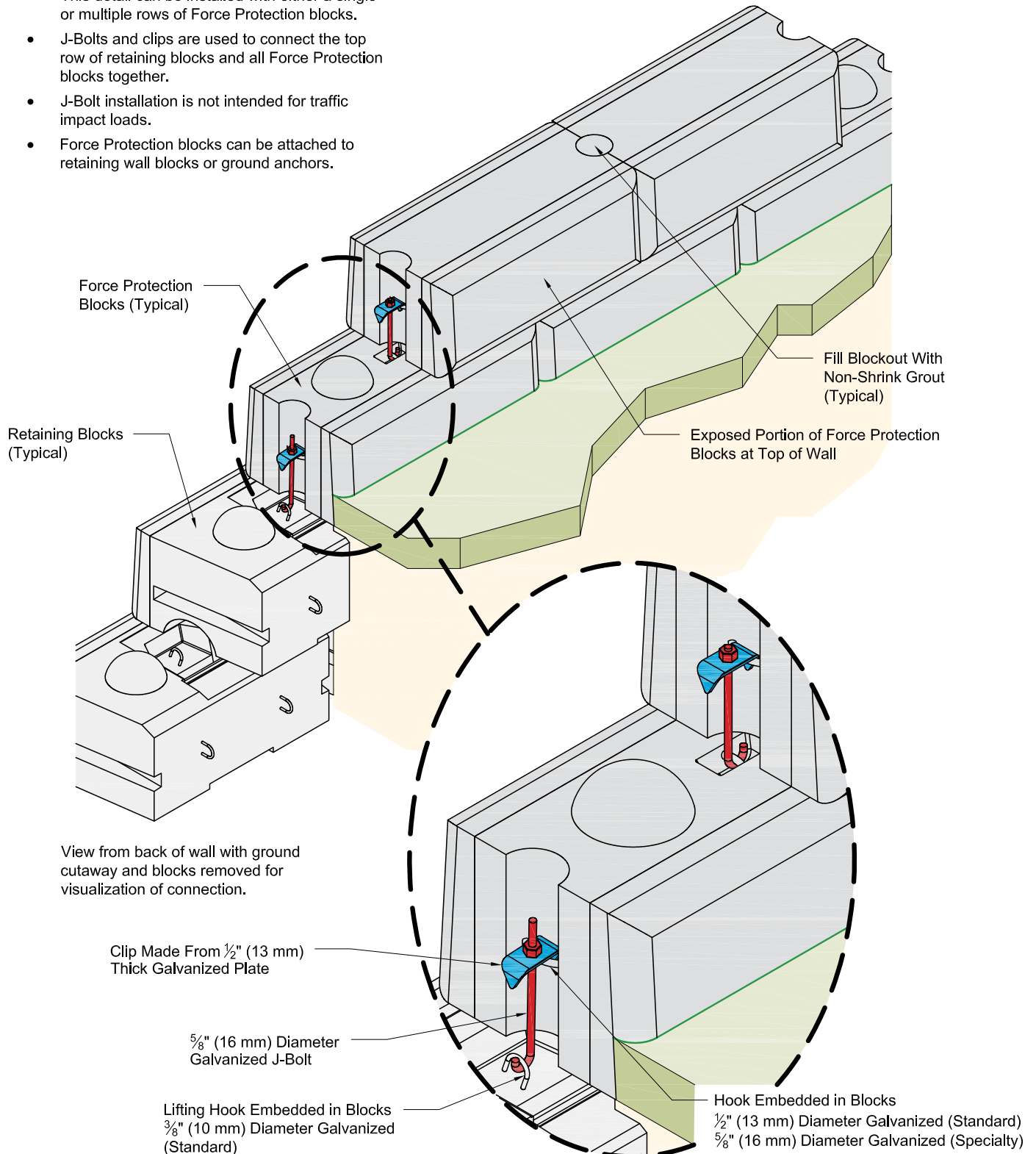

- *This drawing is for reference only.*
- **Final designs for construction must be prepared by a registered Professional Engineer** using the actual conditions of the proposed site.
- **Final wall design must address both internal and external drainage and shall be evaluated by the Professional Engineer who is responsible for the wall design.**

J-BOLT INSTALLATION

J-Bolts can be used to secure force protection walls to the top row of retaining wall blocks (when used on the top of a Redi-Rock wall) or to concrete anchors set in the ground (for a stand alone wall).

Set force protection blocks with the ends centered on ground anchors or the center of Redi-Rock middle retaining wall blocks immediately below.

Place a clip between blocks in hooks provided in the middle of the block on each end.

Place a J-bolt through center of the clip, thread a nut on the J-bolt, and tighten.

Repeat for all remaining courses of force protection blocks.

17. REDI-ROCK COLUMNS

Redi-Rock column blocks are available to complement Redi-Rock walls. Columns can be installed by themselves or with fences or gates.

Column blocks can be placed on properly prepared aggregate or concrete leveling pads or directly on Redi-Rock retaining wall blocks, depending on the specific design for your project.

Column blocks can be manufactured with pockets for concrete or split wood fence rails.

Concrete adhesive or polyurethane sealant can be used between stacked column blocks.

Install a cap on the top of a column. Adjust the cap position until all sides are equidistant and square to the column. Secure the column cap with construction adhesive or polyurethane sealant.

Special inserts are available for mounting gates or similar features to Redi-Rock columns.

Column blocks are available with 4 inch (102 millimeter) or tapered 8 inch (203 millimeter) diameter cores which can be filled with stone or concrete and steel rebar reinforcement.

A conduit can be left through the core if needed for lighting or other features.



Minimum Turning Radius

Convex curves can easily be incorporated into a Redi-Rock wall. Redi-Rock blocks are tapered $7\frac{1}{2}^\circ$ on each side. The smallest radius that can be made with Redi-Rock blocks (without cutting the blocks) occurs when the blocks are placed together with their sides touching. This minimum radius for full size

blocks is 14 feet - 6 inches (4.42 m) from the face of the blocks.

Block to block setback will cause the radius for each succeeding row to be smaller than the row below. To ensure the minimum radius for the top row of blocks in a wall, start with the minimum radius and then

add 2" (51 mm) per course for each standard setback block 18-inch high block, 10" (254 mm) per course for each 9" (230 mm) setback block, and 17" (432 mm) per course for each planter block in the wall below the top row of blocks. For 36-inch high XL blocks, add 4" (101.6 mm) per row.

MINIMUM RADIUS FOR BOTTOM ROW OF BLOCKS

Height of Wall	18-INCH (457 mm) HIGH BLOCKS	36-INCH (914 mm) HIGH XL BLOCKS
	Radius From Face of Block	Radius From Face of Block
1'-6" (0.46 m)	14'-6" (4.42 m)	
3'-0" (0.91 m)	14'-8" (4.47 m)	
4'-6" (1.37 m)	14'-10" (4.52 m)	
6'-0" (1.83 m)	15'-0" (4.57 m)	15'-0" (4.57 m)
7'-6" (2.29 m)	15'-2" (4.62 m)	15'-2" (4.62 m)
9'-0" (2.74 m)	15'-4" (4.67 m)	15'-4" (4.67 m)
10'-6" (3.20 m)	15'-6" (4.72 m)	15'-6" (4.72 m)
12'-0" (3.66 m)	15'-8" (4.78 m)	15'-8" (4.78 m)
13'-6" (4.11 m)	15'-10" (4.83 m)	15'-10" (4.83 m)
15'-0" (4.57 m)	16'-0" (4.88 m)	16'-0" (4.88 m)
16'-6" (5.03 m)		16'-2" (** m)
18'-0" (5.49 m)		6'-4" (4.98 m)
19'-6" (5.94 m)		16'-6" (5.03 m)
21'-0" (6.4 m)		16'-8" (95.08 m)

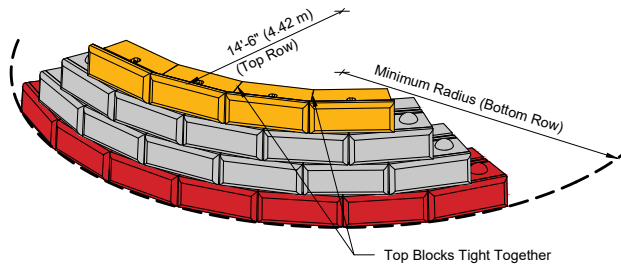

Concave curves may be installed at varying radii. The blocks should be placed tight together to make a smooth curve. Although there is no fixed minimum radius, smaller radii lengths of less than 14'6" (4.42 m) will result in exposing more of the untextured top face of the blocks in the underlying layer.

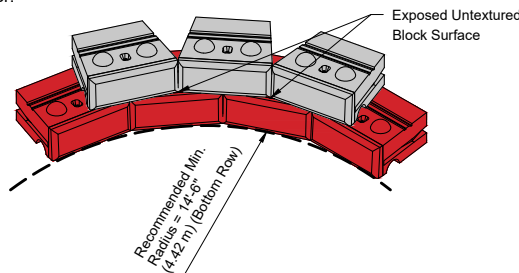

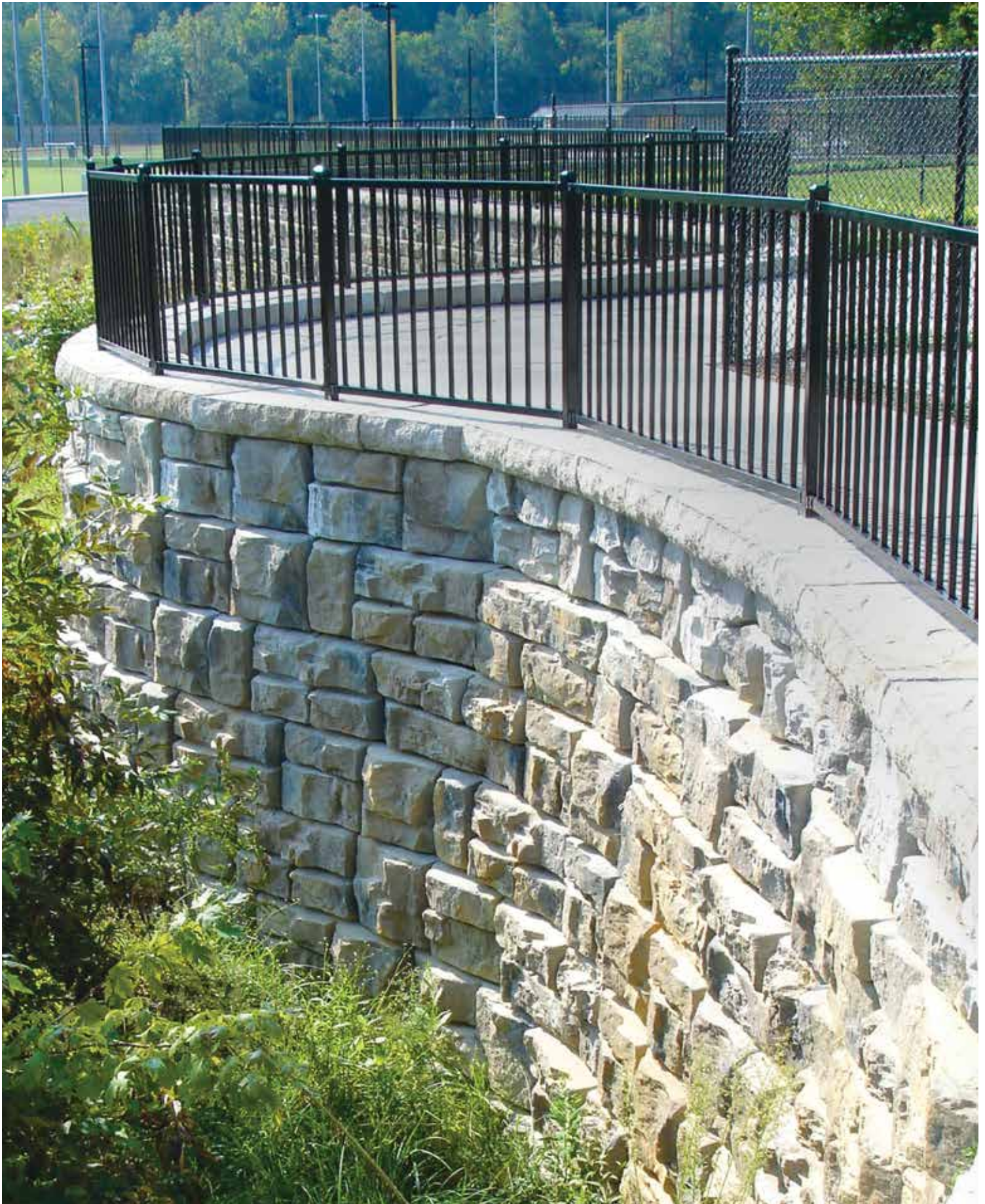





BLOCK LIBRARY

One System, Four Textures, Endless Solutions

The Redi-Rock system is robust, and each of the components can be seamlessly integrated into a cohesive retaining wall design. With the ability to get any block in the Redi-Rock arsenal in four, natural stone textures, it means that technical agility comes with just the right aesthetic touch.

Each local manufacturer produces Redi-Rock in colors that match their natural terrain using molds crafted from real stone and first-use, architectural-grade, precast concrete. That means Redi-Rock walls have detail, durability, and design power—a combination that's hard to come by.

Check out the faces of
Redi-Rock's endless solutions:
LEDGESTONE, COBBLESTONE,
LIMESTONE, AND KINGSTONE.





LEDGESTONE

The rugged relief of Ledgestone blocks give projects a random, stacked stone appearance. With up to 115 square feet (10.5 square meters) of non-repeating texture, it'll be tough to tell all that large block power is behind that pretty face. It's a win-win.



COBBLESTONE

When it comes to classic good looks, Cobblestone is where it's at. Each one-ton block features the appearance of six smaller blocks, creating a timeless aesthetic. Sometimes, the linear appeal of a smaller stacked stone provides the enduring impact you're looking for in a wall.



Ledgestone



Cobblestone

LIMESTONE

The six square feet (0.5 square meters) of face per Limestone block leaves a large, lasting impression. Crafted from real split limestone, the quarried stone texture means there's no need to sacrifice on style for function—you can get both at a grand scale!



KINGSTONE

Striking a balance between the grandiose scale of Limestone and rugged relief of Ledgestone, Kingstone appears weathered by water and time like the crown of a natural stone outcropping. With each Redi-Rock block looking like a large, quarried stone, Kingstone will transform retaining walls into castle-worthy walls.



Limestone



Kingstone

RETAINING BLOCKS (FINISHED TEXTURE ON ONE FACE)

The Redi-Rock Retaining wall blocks come in multiple widths and configurations. The defining characteristic is that Retaining blocks have an aesthetic texture cast into only ONE face, and the textured face is the only side exposed to view in the finished wall. These blocks are machine-placed, wet-cast, precast modular block units manufactured from first purpose, non-reconstituted concrete and intended for constructing dry-stacked modular retaining wall systems. The block units are manufactured from structural-grade concrete mixes in accordance with ASTM C94 or ASTM C685 that produce a finished unit with excellent resistance to freeze-thaw, deicing chemical exposure, and submerged conditions in both fresh water and salt water applications. All Redi-Rock blocks are manufactured and distributed through an international network of individually-owned, licensed precast concrete manufacturers.

CONCRETE MIX PROPERTIES ⁽¹⁾

FREEZE THAW EXPOSURE CLASS ⁽²⁾	MINIMUM 28 DAY COMPRESSIVE STRENGTH ⁽³⁾	MAXIMUM WATER CEMENT RATIO	NOMINAL MAXIMUM AGGREGATE SIZE ⁽¹⁰⁾	AGGREGATE CLASS DESIGNATION ⁽⁴⁾	AIR CONTENT ⁽⁵⁾
MODERATE	4,000 psi (27.6 MPa)	0.45	1.0 (25)	3M	4.5% ± 1.5%
SEVERE	4,000 psi (27.6 MPa)	0.45	1.0 (25)	3S	6.0% ± 1.5%
VERY SEVERE	4,500 psi (30.0 MPa)	0.40	1.0 (25)	4S	6.0% ± 1.5%
MAXIMUM WATER-SOLUBLE CHLORIDE ION (Cl ⁻) CONTENT IN CONCRETE, PERCENT BY WEIGHT OF CEMENT ^(6,7)					0.15
MAXIMUM CHLORIDE AS Cl ⁻ CONCENTRATION IN MIXING WATER, PARTS PER MILLION					1000
MAXIMUM PERCENTAGE OF TOTAL CEMENTITIOUS MATERIALS BY WEIGHT ^(8,10) (VERY SEVERE EXPOSURE CLASS ONLY)					
FLY ASH OR OTHER POZZOLANS PER ASTM C618		25	TOTAL ASH, POZZOLANS, SLAG, AND SILICA FUME ⁽⁹⁾		50
SLAG CONFORMING TO ASTM C989		50	TOTAL ASH, POZZOLANS, AND SILICA FUME ⁽⁹⁾		35
SILICA FUME CONFORMING TO ASTM C1240		10	ALKALI-AGGREGATE REACTIVITY MITIGATION PER ACI 201		

REFERENCE DIMENSIONS:

HEIGHT = VERTICAL DIMENSION OF TEXTURED FACE
 LENGTH = HORIZONTAL DIMENSION PARALLEL TO TEXTURED FACE
 WIDTH = HORIZONTAL DIMENSION PERPENDICULAR TO TEXTURED FACE

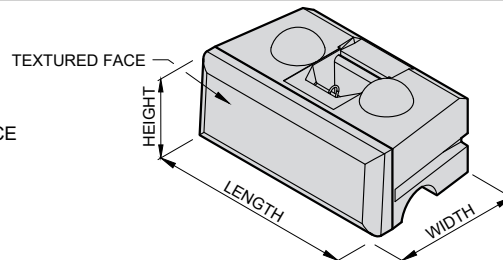

DIMENSIONAL TOLERANCES ^{(11) (12)}

HEIGHT	ALL BLOCKS	18 ± 3/16 (457 ± 5) or 36 ± 3/16 (914 ± 5)
LENGTH	FULL BLOCKS	46 5/8 ± 1/2 (1172 ± 13)
	HALF BLOCKS	22 3/16 ± 1/2 (579 ± 13)
WIDTH	28" (710) BLOCKS	22 5/8 ± 1/2 (575 ± 13) FORM LINE TO BACK OF BLOCK, PLUS APPROXIMATELY 5 3/8 (136) FACE TEXTURE
	41" (1030) BLOCKS	35 5/8 ± 1/2 (892 ± 13) FORM LINE TO BACK OF BLOCK, PLUS APPROXIMATELY 5 3/8 (136) FACE TEXTURE
	60" (1520) BLOCKS	54 5/8 ± 1/2 (1387 ± 13) FORM LINE TO BACK OF BLOCK, PLUS APPROXIMATELY 5 3/8 (136) FACE TEXTURE
	52" (1320) XL BLOCKS	46 5/8 ± 1/2 (1184 ± 13) FORM LINE TO BACK OF BLOCK, PLUS APPROXIMATELY 5 3/8 (136) FACE TEXTURE
	72" (1830) XL BLOCKS	66 5/8 ± 1/2 (1692 ± 13) FORM LINE TO BACK OF BLOCK, PLUS APPROXIMATELY 5 3/8 (136) FACE TEXTURE
	96" (2440) XL BLOCKS	90 5/8 ± 1/2 (2302 ± 13) FORM LINE TO BACK OF BLOCK, PLUS APPROXIMATELY 5 3/8 (136) FACE TEXTURE

⁽¹⁾ Concrete mix properties are in general accordance with ACI 318 durability requirements. Research has shown that concrete manufactured to these standards demonstrates good durability and performance. When these requirements are followed, specific freeze-thaw testing of the concrete is typically NOT required.

⁽²⁾ Exposure class is as described in ACI 318.

⁽³⁾ Test method ASTM C39.

⁽⁴⁾ Defined in ASTM C33 Table 3 *Limits for Deleterious Substances and Physical Property Requirements of Coarse Aggregate for Concrete*.

⁽⁵⁾ Test method ASTM C231.

⁽⁶⁾ Test method ASTM C1218 at age between 28 and 42 days.

⁽⁷⁾ Where used in high sulfate environments or where alkali-silica reactivity is an issue, water-soluble chloride shall be limited to no more than trace amounts (from impurities in concrete-making components, not intended constituents.)

⁽⁸⁾ The total cementitious material also includes ASTM C150, C595, C845, and C1157 cement. The maximum percentages shall include:

(a) Fly ash or other pozzolans in type IP, blended cement, ASTM C595, or ASTM C1157.

(b) Slag used in the manufacture of an IS blended cement, ASTM C595, or ASTM C1157.

(c) Silica fume, ASTM C1240, present in a blended cement.

⁽⁹⁾ Fly ash or other pozzolans and silica fume shall constitute no more than 25 and 10 percent, respectively, of the total weight of the cementitious materials.

⁽¹⁰⁾ Prescriptive limits shown may be waived for concrete mixes that demonstrate excellent freeze-thaw durability in a detailed and current testing program.

⁽¹¹⁾ All dimensions are shown in units of inches (mm).

⁽¹²⁾ Permissible defects: Chips smaller than 1.5" (38mm) in its largest dimension and cracks not wider than 0.012" (0.305mm) and not longer than 25% of the nominal height of the block; bug holes in the architectural face smaller than 0.75" (19mm); and bug holes, water marks, and color variation on non-architectural faces.

RETAINING BLOCKS

Block Library

R-28T 28" (710mm) TOP			R-28HT 28" (710mm) HALF TOP		
Face Texture:	Cobble / Limestone	Kingstone / Ledgestone	Face Texture:	Cobble / Limestone	Kingstone / Ledgestone
Block Weight:	1230 lb (557 kg)	1160 lb (530 kg)	Block Weight:	570 lb (260 kg)	540 lb (240 kg)
Block Volume:	8.57 ft ³ (0.243 m ³)	8.07 ft ³ (0.229 m ³)	Block Volume:	4.01 ft ³ (0.113 m ³)	3.76 ft ³ (0.106 m ³)
Center of Gravity:	14.9" (378mm)	14.2" (362mm)	Center of Gravity:	15.3" (389 mm)	14.7" (373 mm)

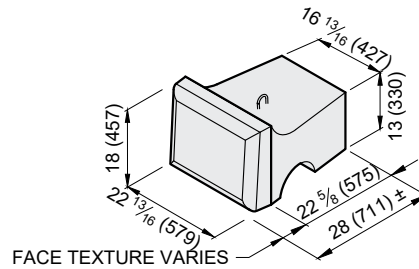
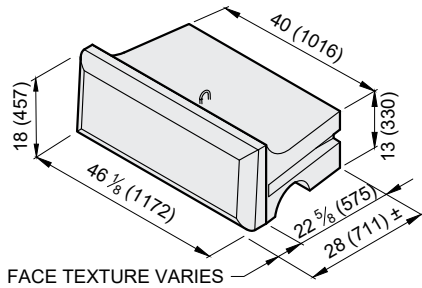

R-28M 28" (710mm) MIDDLE			R-28HM 28" (710mm) HALF MIDDLE		
Face Texture:	Cobble / Limestone	Kingstone / Ledgestone	Face Texture:	Cobble / Limestone	Kingstone / Ledgestone
Block Weight:	1610 lb (730 kg)	1540 lb (700 kg)	Block Weight:	750 lb (340 kg)	710 lb (320 kg)
Block Volume:	11.28 ft ³ (0.319 m ³)	10.78 ft ³ (0.305 m ³)	Block Volume:	5.23 ft ³ (0.148 m ³)	4.98 ft ³ (0.141 m ³)
Center of Gravity:	13.9" (354 mm)	13.4" (340 mm)	Center of Gravity:	14.3" (364 mm)	13.8" (350 mm)

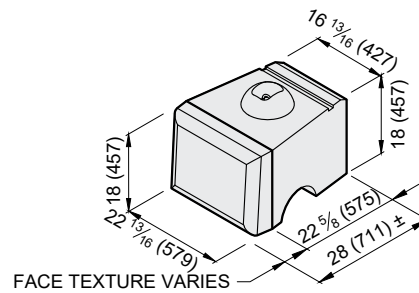
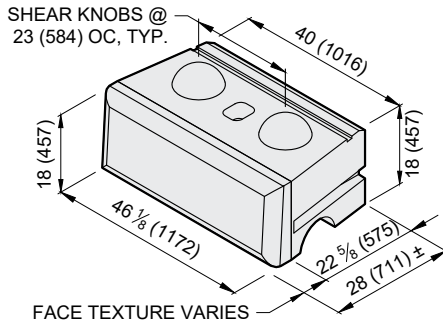

R-28B 28" (710mm) BOTTOM			R-28HB 28" (710mm) HALF BOTTOM		
Face Texture:	Cobble / Limestone	Kingstone / Ledgestone	Face Texture:	Cobble / Limestone	Kingstone / Ledgestone
Block Weight:	1740 lb (790 kg)	1670 lb (760 kg)	Block Weight:	810 lb (370 kg)	770 lb (350 kg)
Block Volume:	12.19 ft ³ (0.345 m ³)	11.70 ft ³ (0.331 m ³)	Block Volume:	5.66 ft ³ (0.160 m ³)	5.41 ft ³ (0.153 m ³)
Center of Gravity:	14.0" (355 mm)	13.5" (343 mm)	Center of Gravity:	14.3" (364 mm)	13.8" (352 mm)

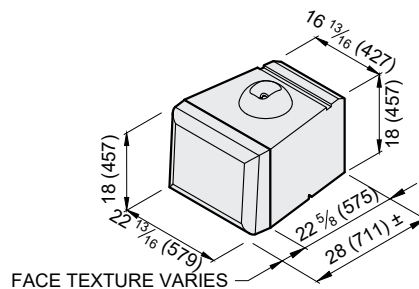
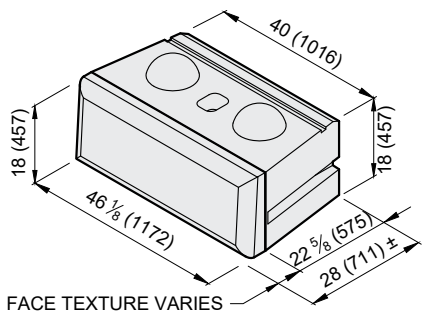

- Units for dimensions are inches (mm), typical unless noted otherwise.
- Block production varies with each licensed Redi-Rock manufacturer. Confirm availability before Specifying or Ordering.
- Center of Gravity is measured from the back of block.
- Actual block volumes and weights may vary.
- Weights are based upon a concrete density of 143 lb/ft³ (2291kg/m³).
- Half blocks contain a fork slot on only one side of the block.
- Interface Shear knobs are typically 10" (254mm) diameter by 4" (102mm) tall. Smaller knob diameters are available.

RETAINING BLOCKS

Block Library

R-41T 41" (1030mm) TOP *			R-41HT 41" (1030mm) HALF TOP *		
Face Texture:	Cobble / Limestone	Kingstone / Ledgestone	Face Texture:	Cobble / Limestone	Kingstone / Ledgestone
Block Weight:	1750 lb (790 kg)	1680 lb (760 kg)	Block Weight:	770 lb (350 kg)	740 lb (330 kg)
Block Volume:	12.22 ft ³ (0.346 m ³)	11.73 ft ³ (0.332 m ³)	Block Volume:	5.38 ft ³ (0.15 m ³)	5.14 ft ³ (0.15 m ³)
Center of Gravity:	21.3" (540 mm)	20.6" (522 mm)	Center of Gravity:	22.4" (568 mm)	21.6" (550 mm)

SPECIALITY BLOCK

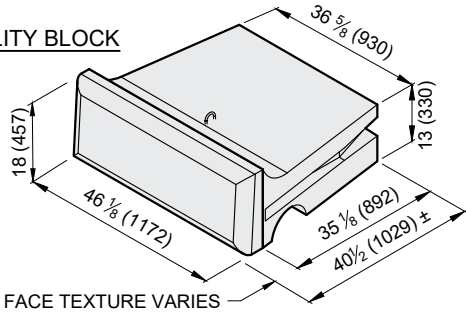

SPECIALITY BLOCK

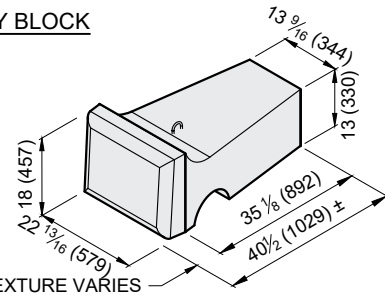

R-41M 41" (1030mm) MIDDLE			R-41HM 41" (1030mm) HALF MIDDLE		
Face Texture:	Cobble / Limestone	Kingstone / Ledgestone	Face Texture:	Cobble / Limestone	Kingstone / Ledgestone
Block Weight:	2310 lb (1050 kg)	2240 lb (1020 kg)	Block Weight:	1020 lb (460 kg)	990 lb (450 kg)
Block Volume:	16.14 ft ³ (0.457 m ³)	15.65 ft ³ (0.443 m ³)	Block Volume:	7.14 ft ³ (0.20 m ³)	6.90 ft ³ (0.20 m ³)
Center of Gravity:	20.4" (518 mm)	19.8" (504 mm)	Center of Gravity:	21.4" (543 mm)	20.8" (528 mm)

SHEAR KNOBS @ 23 (584) OC, TYP.

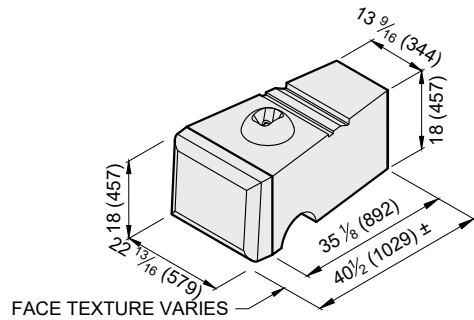
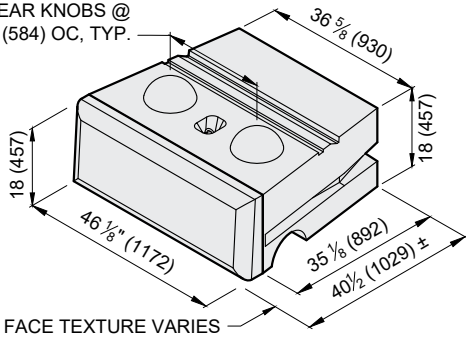

R-41B 41" (1030mm) BOTTOM			R-41HB 41" (1030mm) HALF BOTTOM		
Face Texture:	Cobble / Limestone	Kingstone / Ledgestone	Face Texture:	Cobble / Limestone	Kingstone / Ledgestone
Block Weight:	2440 lb (1110 kg)	2370 lb (1070 kg)	Block Weight:	1080 lb (490 kg)	1050 lb (480 kg)
Block Volume:	17.06 ft ³ (0.483 m ³)	16.56 ft ³ (0.469 m ³)	Block Volume:	7.58 ft ³ (0.21 m ³)	7.33 ft ³ (0.21 m ³)
Center of Gravity:	20.7" (527 mm)	20.2" (514 mm)	Center of Gravity:	21.7" (551 mm)	21.2" (538 mm)

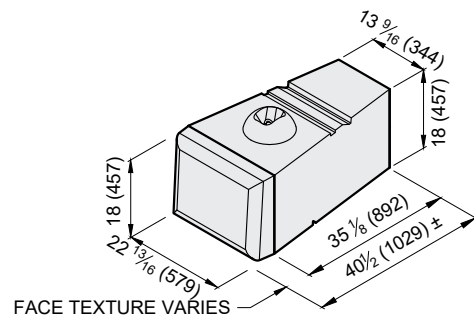
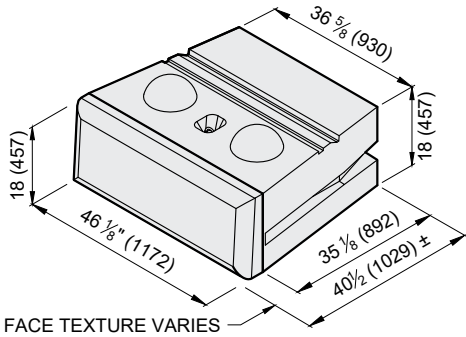

- Units for dimensions are inches (mm), typical unless noted otherwise.
- Block production varies with each licensed Redi-Rock manufacturer. Confirm availability before Specifying or Ordering.
- Center of Gravity is measured from the back of block.
- Actual block volumes and weights may vary.
- Weights are based upon a concrete density of 143 lb/ft³ (2291kg/m³).
- Half blocks contain a fork slot on only one side of the block.
- Interface Shear knobs are typically 10" (254mm) diameter by 4" (102mm) tall. Smaller knob diameters are available.
- * 41" (1030mm) Top blocks are not typical and used in limited applications.

RETAINING BLOCKS

Block Library

R-60M 60" (1520mm) MIDDLE			R-60HM 60" (1520mm) HALF MIDDLE		
Face Texture:	Cobble / Limestone	Kingstone / Ledgestone	Face Texture:	Cobble / Limestone	Kingstone / Ledgestone
Block Weight:	3290 lb (1490 kg)	3220 lb (1460 kg)	Block Weight:	1340 lb (610 kg)	1300 lb (590 kg)
Block Volume:	23.00 ft ³ (0.651 m ³)	22.49 ft ³ (0.637 m ³)	Block Volume:	9.34 ft ³ (0.264 m ³)	9.09 ft ³ (0.258 m ³)
Center of Gravity:	31.0" (786 mm)	30.4" (772 mm)	Center of Gravity:	33.7" (856 mm)	33.1" (840 mm)

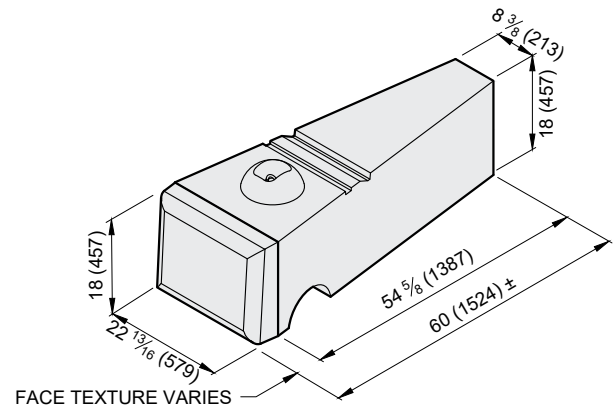
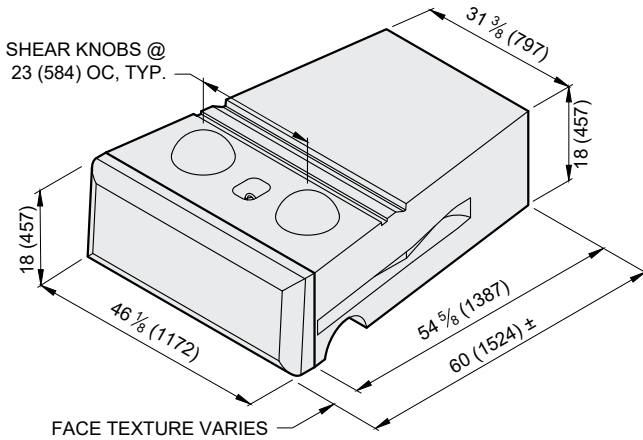

R-60B 60" (1520mm) BOTTOM			R-60HB 60" (1520mm) HALF BOTTOM		
Face Texture:	Cobble / Limestone	Kingstone / Ledgestone	Face Texture:	Cobble / Limestone	Kingstone / Ledgestone
Block Weight:	3420 lb (1550 kg)	3350 lb (1520 kg)	Block Weight:	1400 lb (630 kg)	1360 lb (620 kg)
Block Volume:	23.90 ft ³ (0.677 m ³)	23.40 ft ³ (0.663 m ³)	Block Volume:	9.77 ft ³ (0.277 m ³)	9.52 ft ³ (0.270 m ³)
Center of Gravity:	31.6" (802 mm)	31.0" (788 mm)	Center of Gravity:	34.3" (871 mm)	33.7" (856 mm)

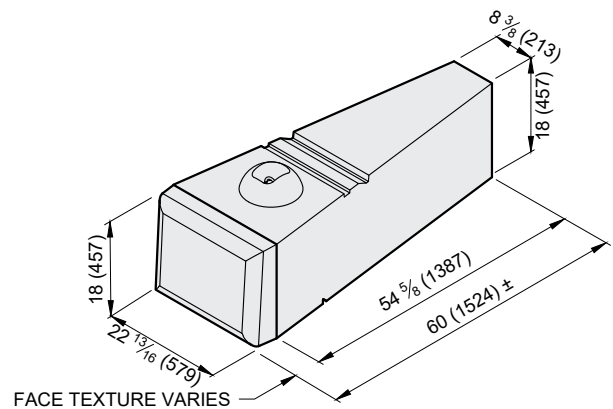
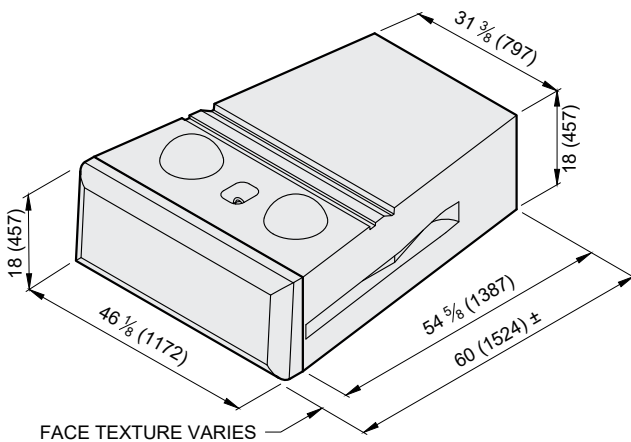

1. Units for dimensions are inches (mm), typical unless noted otherwise.
2. Block production varies with each licensed Redi-Rock manufacturer. Confirm availability before Specifying or Ordering.
3. Center of Gravity is measured from the back of block.
4. Actual block volumes and weights may vary.

5. Weights are based upon a concrete density of 143 lb/ft³ (2291kg/m³).
6. 60" (1520 mm) are typically used at the bottom of taller walls.
7. Half blocks contain a fork slot on only one side of the block.
8. Interface Shear knobs are typically 10" (254mm) diameter by 4" (102mm) tall. Smaller knob diameters are available.

RETAINING BLOCKS

Block Library

R-5236HC 52" (1320 mm) XL Hollow-Core

Face Texture:	Ledgestone
Block Weight:	3330 lb (1510 kg)
Block Volume:	23.29 ft ³ (0.660 m ³)
Infill Volume:	22.88 ft ³ (0.648 m ³)
Center of Gravity:	29.0" (737 mm)

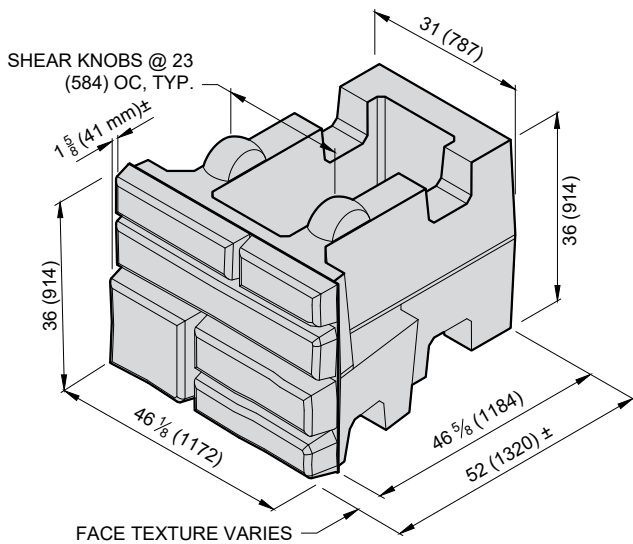

R-7236HC 72" (1830 mm) XL Hollow-Core

Face Texture:	Ledgestone
Block Weight:	4160 lb (1890 kg)
Block Volume:	29.10 ft ³ (0.824 m ³)
Infill Volume:	36.29 ft ³ (1.028 m ³)
Center of Gravity:	39.9" (1013 mm)

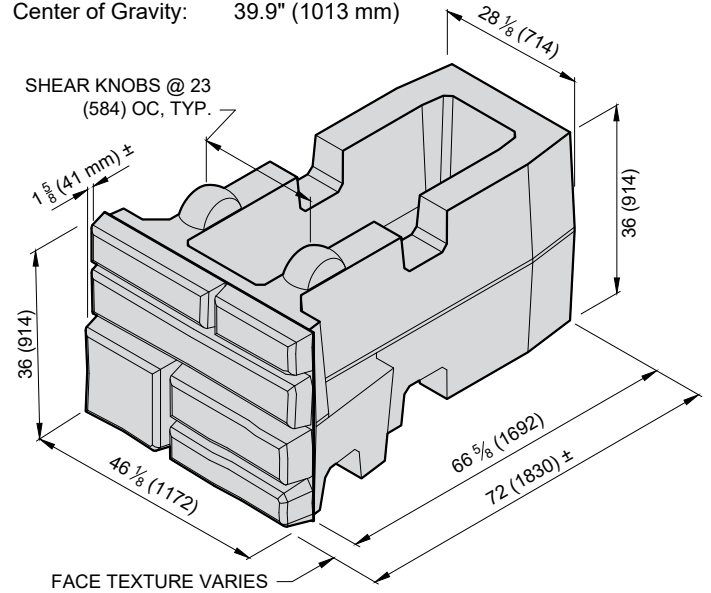

R-9636HC 96" (2440 mm) XL Hollow-Core

Face Texture:	Ledgestone
Block Weight:	4840 lb (2190 kg)
Block Volume:	33.83 ft ³ (0.958 m ³)
Infill Volume:	54.63 ft ³ (1.547 m ³)
Center of Gravity:	55.3" (1405 mm)

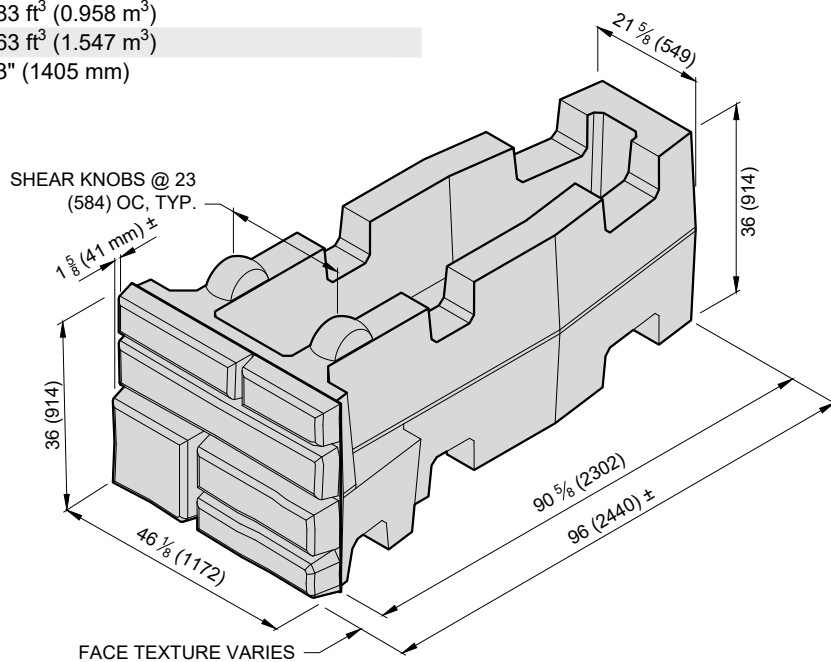

- Units for dimensions are inches (mm), typical unless noted otherwise.
- Block production varies with each licensed Redi-Rock manufacturer. Confirm availability before Specifying or Ordering.
- Center of Gravity is measured from the back of block, excluding stone infill.
- Actual block volumes and weights may vary.
- Weights are based upon a concrete density of 143 lb/ft³ (2291kg/m³).
- Interface Shear knobs are nominally 10" (254mm) diameter by 4" (102 mm) tall.

RETAINING BLOCKS

Block Library

R-419M		41" (1030mm) MIDDLE 9" (230mm) SETBACK		R-419HM	
Face Texture:	Cobble / Limestone	Kingstone / Ledgestone	Face Texture:	Cobble / Limestone	Kingstone / Ledgestone
Block Weight:	2320 lb (1050 kg)	2250 lb (1020 kg)	Block Weight:	1030 lb (470 kg)	1000 lb (450 kg)
Block Volume:	16.21 ft ³ (0.46 m ³)	15.72 ft ³ (0.44 m ³)	Block Volume:	7.20 ft ³ (0.20 m ³)	6.96 ft ³ (0.20 m ³)
Center of Gravity:	20.2" (514 mm)	19.7" (500 mm)	Center of Gravity:	21.3" (540 mm)	20.7" (525 mm)

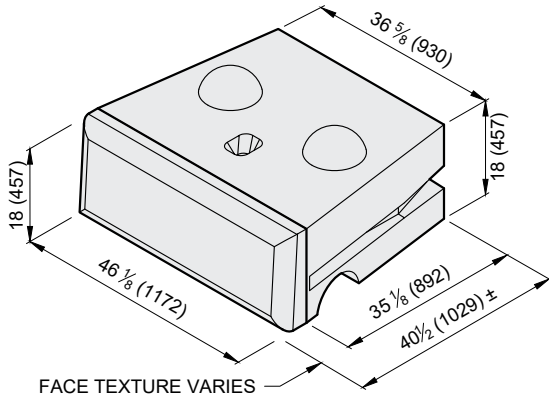

FULL MIDDLE

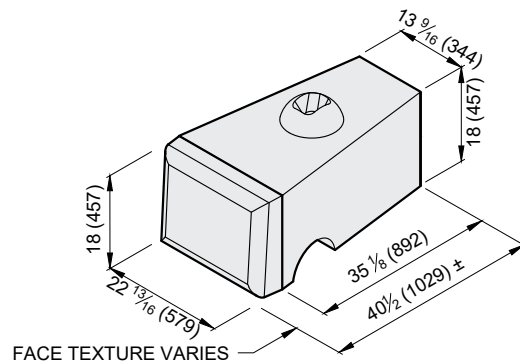

HALF MIDDLE

R-419B		41" (1030mm) BOTTOM 9" (230mm) SETBACK		R-419HB	
Face Texture:	Cobble / Limestone	Kingstone / Ledgestone	Face Texture:	Cobble / Limestone	Kingstone / Ledgestone
Block Weight:	2450 lb (1110 kg)	2380 lb (1080 kg)	Block Weight:	1090 lb (500 kg)	1060 lb (480 kg)
Block Volume:	17.13 ft ³ (0.48 m ³)	16.63 ft ³ (0.47 m ³)	Block Volume:	7.63 ft ³ (0.22 m ³)	7.39 ft ³ (0.21 m ³)
Center of Gravity:	20.6" (523 mm)	20.1" (510 mm)	Center of Gravity:	21.6" (548 mm)	21.0" (534 mm)

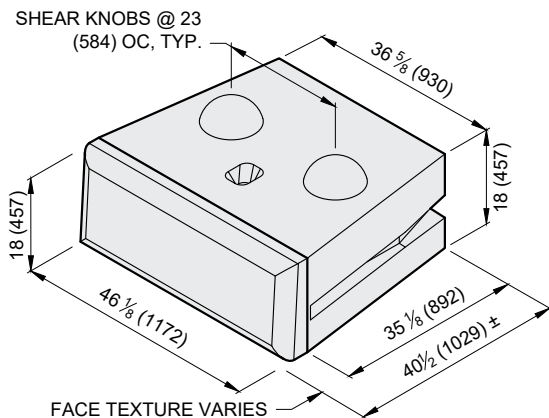

FULL BOTTOM

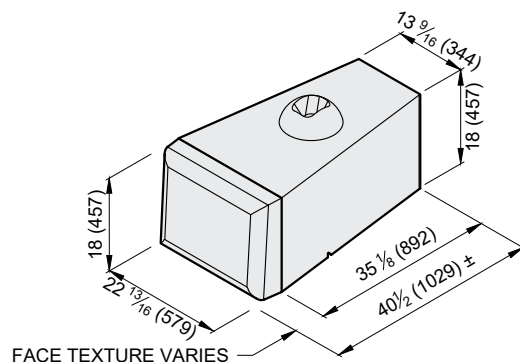

HALF BOTTOM

- Units for dimensions are inches (mm), typical unless noted otherwise.
- Block production varies with each licensed Redi-Rock manufacturer. Confirm availability before Specifying or Ordering.
- Center of Gravity is measured from the back of block.
- Actual block volumes and weights may vary.
- Weights are based upon a concrete density of 143 lb/ft³ (2291kg/m³).
- Half blocks contain a fork slot on only one side of the block.
- Interface Shear knobs are typically 10" (254mm) diameter by 4" (102 mm) tall.

RETAINING BLOCKS

Block Library

R-609M	60" (1520mm) MIDDLE 9" (230mm) SETBACK		R-609HM		
Face Texture:	Cobble / Limestone	Kingstone / Ledgestone	Face Texture:	Cobble / Limestone	Kingstone / Ledgestone
Block Weight:	3300 lb (1500 kg)	3230 lb (1460 kg)	Block Weight:	1340 lb (610 kg)	1310 lb (590 kg)
Block Volume:	23.06 ft ³ (0.65 m ³)	22.56 ft ³ (0.64 m ³)	Block Volume:	9.37 ft ³ (0.26 m ³)	9.12 ft ³ (0.26 m ³)
Center of Gravity:	30.9" (785 mm)	30.3" (770 mm)	Center of Gravity:	33.6" (855 mm)	33.0" (839 mm)

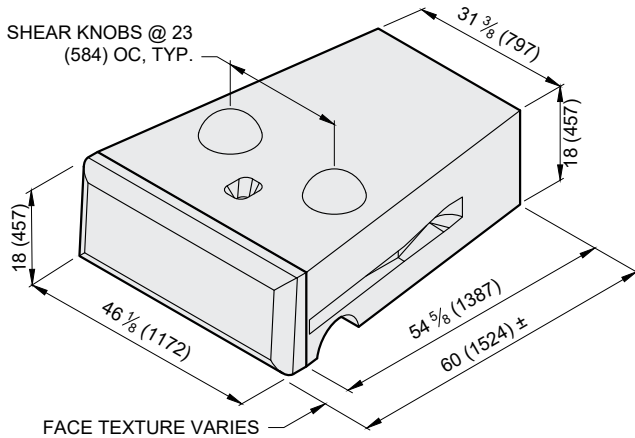

FULL MIDDLE

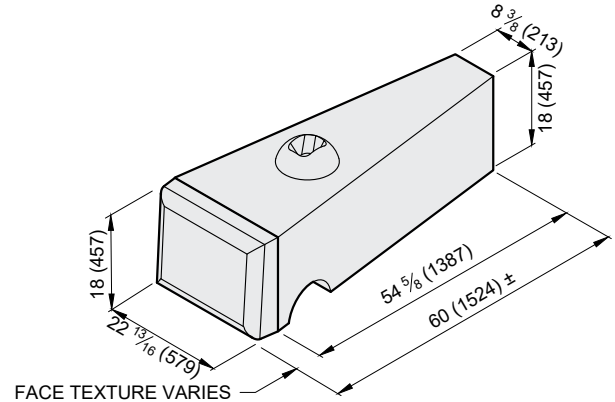

HALF MIDDLE

R-609B	60" (1520mm) BOTTOM 9" (230mm) SETBACK		R-609HB		
Face Texture:	Cobble / Limestone	Kingstone / Ledgestone	Face Texture:	Cobble / Limestone	Kingstone / Ledgestone
Block Weight:	3430 lb (1550 kg)	3360 lb (1520 kg)	Block Weight:	1400 lb (640 kg)	1370 lb (620 kg)
Block Volume:	23.97 ft ³ (0.68 m ³)	23.47 ft ³ (0.66 m ³)	Block Volume:	9.80 ft ³ (0.28 m ³)	9.55 ft ³ (0.27 m ³)
Center of Gravity:	31.5" (800 mm)	30.9" (786 mm)	Center of Gravity:	34.2" (869 mm)	33.6" (854 mm)

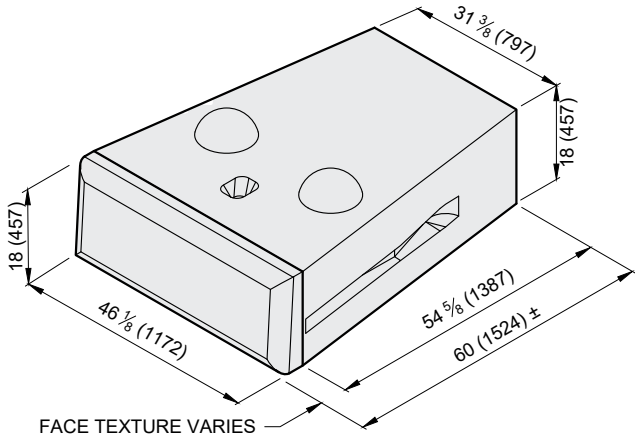

FULL BOTTOM

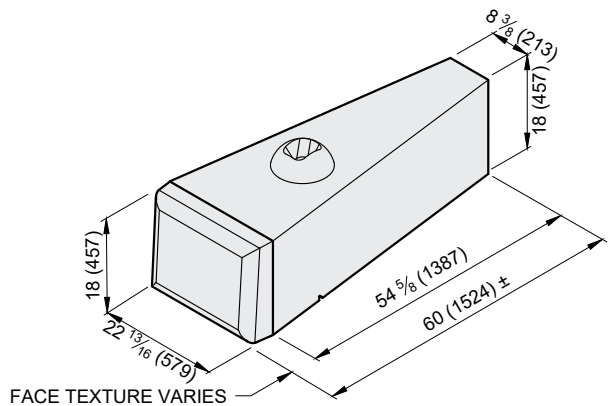

HALF BOTTOM

1. Units for dimensions are inches (mm), typical unless noted otherwise.
2. Block production varies with each licensed Redi-Rock manufacturer. Confirm availability before Specifying or Ordering.
3. Center of Gravity is measured from the back of block.
4. Actual block volumes and weights may vary.
5. Weights are based upon a concrete density of 143 lb/ft³ (2291kg/m³).
6. Half blocks contain a fork slot on only one side of the block.
7. Interface Shear knobs are typically 10" (254mm) diameter by 4" (102 mm) tall.
8. 60" (1520 mm) Blocks are typically used at the bottom of taller walls.

RETAINING BLOCKS

Block Library

R-28PCT 28" (710mm) PC TOP

Face Texture:	Cobble / Limestone	Kingstone / Ledgestone
Block Weight:	1170 lb (530 kg)	1100 lb (500 kg)
Block Volume:	8.16 ft ³ (0.231 m ³)	7.66 ft ³ (0.217 m ³)
Center of Gravity:	15.3" (388 mm)	14.6" (372 mm)

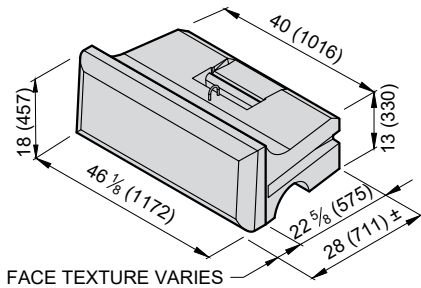

R-41PCT 41" (1030mm) PC TOP

Face Texture:	Cobble / Limestone	Kingstone / Ledgestone
Block Weight:	1630 lb (740 kg)	1560 lb (710 kg)
Block Volume:	11.38 ft ³ (0.32 m ³)	10.88 ft ³ (0.31 m ³)
Center of Gravity:	21.8" (554 mm)	21.1" (536 mm)

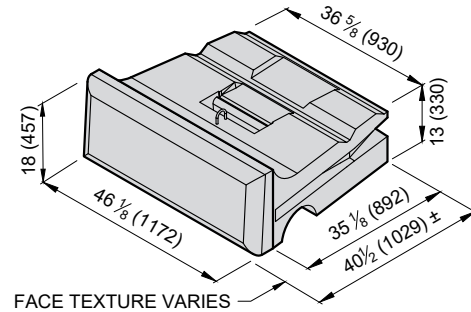

R-28PCM 28" (710mm) PC MIDDLE

Face Texture:	Cobble / Limestone	Kingstone / Ledgestone
Block Weight:	1520 lb (690 kg)	1450 lb (660 kg)
Block Volume:	10.62 ft ³ (0.301 m ³)	10.12 ft ³ (0.287 m ³)
Center of Gravity:	14.2" (360 mm)	13.6" (346 mm)

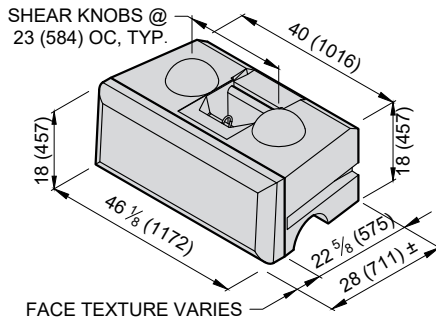

R-41PCM 41" (1030mm) PC MIDDLE

Face Texture:	Cobble / Limestone	Kingstone / Ledgestone
Block Weight:	2170 lb (990 kg)	2100 lb (950 kg)
Block Volume:	15.2 ft ³ (0.43 m ³)	14.69 ft ³ (0.42 m ³)
Center of Gravity:	20.6" (522 mm)	20.0" (508 mm)

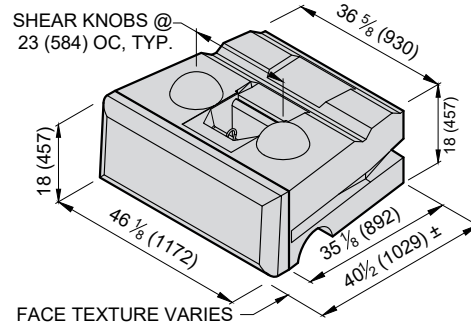

R-28PCB 28" (710mm) PC BOTTOM

Face Texture:	Cobble / Limestone	Kingstone / Ledgestone
Block Weight:	1620 lb (740 kg)	1550 lb (700 kg)
Block Volume:	11.34 ft ³ (0.321 m ³)	10.85 ft ³ (0.307 m ³)
Center of Gravity:	14.2" (362 mm)	13.7" (349 mm)

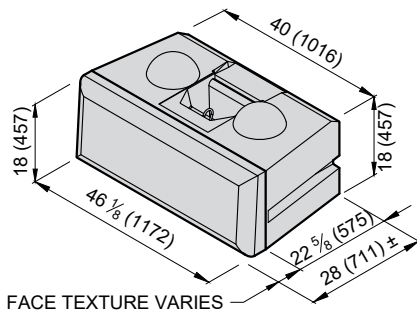

R-41PCB 41" (1030mm) PC BOTTOM

Face Texture:	Cobble / Limestone	Kingstone / Ledgestone
Block Weight:	2280 lb (1030 kg)	2210 lb (1000 kg)
Block Volume:	15.92 ft ³ (0.45 m ³)	15.42 ft ³ (0.44 m ³)
Center of Gravity:	20.2" (514mm)	19.7" (501mm)

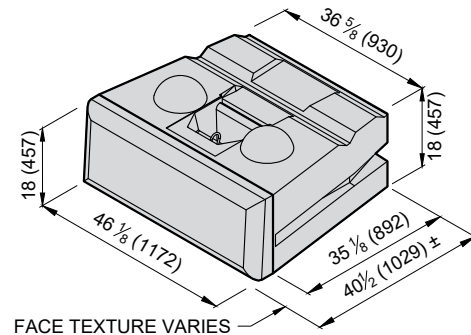

1. Units for dimensions are inches (mm), typical unless noted otherwise.
2. Block production varies with each licensed Redi-Rock manufacturer. Confirm availability before Specifying or Ordering.
3. Center of Gravity is measured from the back of block.
4. Actual block volumes and weights may vary.

5. Weights are based upon a concrete density of 143 lb/ft³ (2291kg/m³).
6. Blocks contain a vertical slot for a 12" (300 mm) strip of geogrid soil reinforcement.
7. Interface Shear knobs are typically 10" (254mm) diameter by 4" (102 mm) tall. Smaller knob diameters are available.

RETAINING BLOCKS

Block Library

R-41PL 41" (1030mm) PLANTER			R-41HPL 41" (1030mm) HALF PLANTER		
Face Texture:	Cobble / Limestone	Kingstone / Ledgestone	Face Texture:	Cobble / Limestone	Kingstone / Ledgestone
Block Weight:	2010 lb (910 kg)	1930 lb (880 kg)	Block Weight:	880 lb (400 kg)	840 lb (380 kg)
Block Volume:	14.02 ft ³ (0.40 m ³)	13.53 ft ³ (0.38 m ³)	Block Volume:	6.14 ft ³ (0.17 m ³)	5.89 ft ³ (0.17 m ³)
Center of Gravity:	19.1" (485 mm)	18.4" (468 mm)	Center of Gravity:	20.2" (513 mm)	19.5" (495 mm)

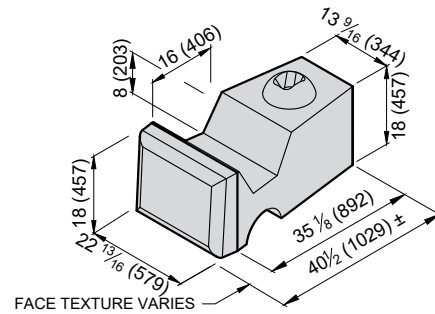
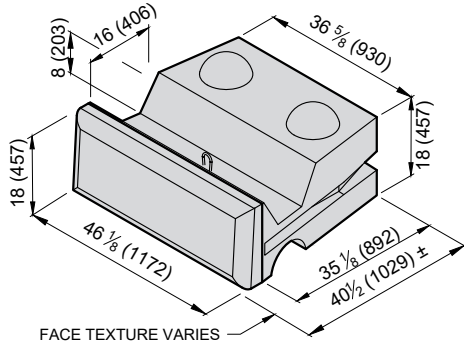

R-MT MODIFIED TOP			R-MHT MODIFIED HALF TOP		
Face Texture:	Cobble / Limestone	Kingstone / Ledgestone	Face Texture:	Cobble / Limestone	Kingstone / Ledgestone
Block Weight:	1200 lb (540 kg)	1130 lb (510 kg)	Block Weight:	710 lb (320 kg)	640 lb (290 kg)
Block Volume:	8.38 ft ³ (0.24 m ³)	7.88 ft ³ (0.22 m ³)	Block Volume:	4.95 ft ³ (0.14 m ³)	4.45 ft ³ (0.13 m ³)
Center of Gravity:	17.9" (455 mm)	17.2" (438 mm)	Center of Gravity:	20.7" (527 mm)	19.8" (504 mm)

SPECIALITY BLOCK

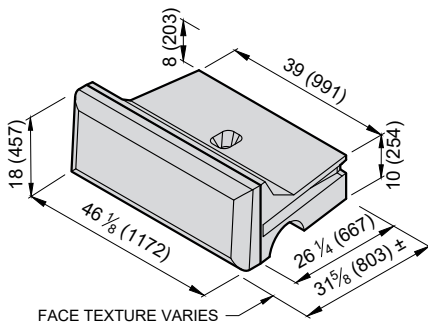

SPECIALITY BLOCK

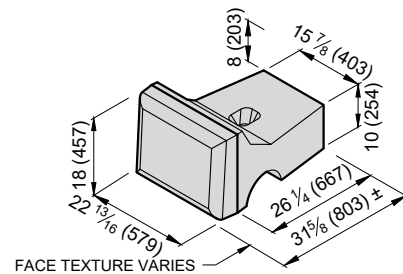

1. Units for dimensions are inches (mm), typical unless noted otherwise.
2. Block production varies with each licensed Redi-Rock manufacturer. Confirm availability before Specifying or Ordering.
3. Center of Gravity is measured from the back of block.
4. Actual block volumes and weights may vary.

5. Weights are based upon a concrete density of 143 lb/ft³ (2291kg/m³).
6. Half blocks contain a fork slot on only one side of the block.
7. Interface Shear knobs are typically 10" (254 mm) diameter by 4" (102 mm) tall.

RETAINING BLOCKS

Block Library

R-AB ANCHOR BOTTOM			R-AM ANCHOR MIDDLE		
Face Texture:	Cobble / Limestone	Kingstone / Ledgestone	Face Texture:	Cobble / Limestone	Kingstone / Ledgestone
Block Weight:	2370 lb (1070 kg)	2290 lb (1040 kg)	Block Weight:	2240 lb (1010 kg)	2160 lb (980 kg)
Block Volume:	16.54 ft ³ (0.47 m ³)	16.04 ft ³ (0.45 m ³)	Block Volume:	15.63 ft ³ (0.44 m ³)	15.13 ft ³ (0.43 m ³)
Center of Gravity:	21.0" (533 mm)	20.4" (519 mm)	Center of Gravity:	20.6" (523 mm)	20.0" (509 mm)

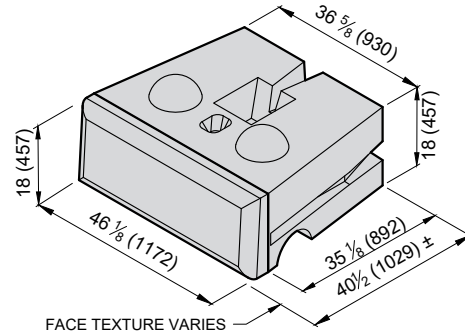
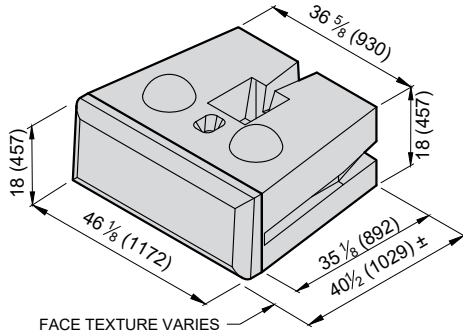

R-SM SHORT MIDDLE			R-ST SHORT TOP		
Face Texture:	Cobble / Limestone	Kingstone / Ledgestone	Face Texture:	Cobble / Limestone	Kingstone / Ledgestone
Block Weight:	2140 lb (970 kg)	2080 lb (940 kg)	Block Weight:	1110 lb (500 kg)	1050 lb (480 kg)
Block Volume:	14.95 ft ³ (0.42 m ³)	14.51 ft ³ (0.41 m ³)	Block Volume:	7.77 ft ³ (0.22 m ³)	7.33 ft ³ (0.21 m ³)
Center of Gravity:	19.7" (499mm)	19.2" (487mm)	Center of Gravity:	13.7" (349mm)	13.2" (336mm)

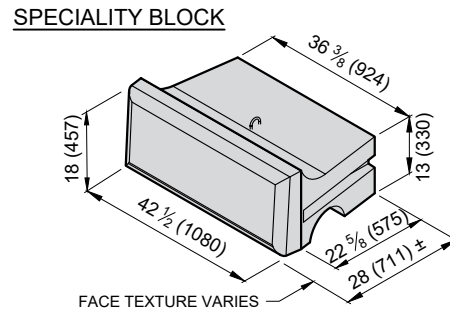
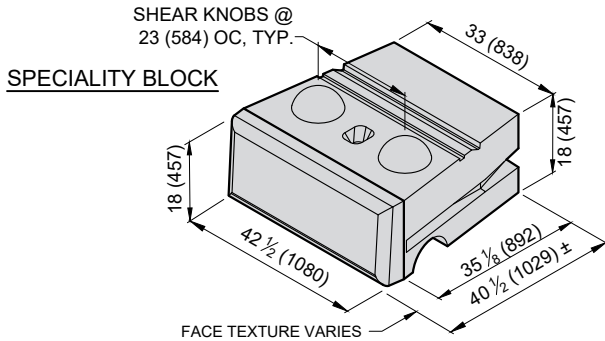

R-419SM 9" (230mm) SETBACK SHORT MID			R-419ST 9" (230mm) SETBACK SHORT TOP		
Face Texture:	Cobble / Limestone	Kingstone / Ledgestone	Face Texture:	Cobble / Limestone	Kingstone / Ledgestone
Block Weight:	1280 lb (580 kg)	1240 lb (560 kg)	Block Weight:	710 lb (320 kg)	660 lb (300 kg)
Block Volume:	8.96 ft ³ (0.25 m ³)	8.66 ft ³ (0.24 m ³)	Block Volume:	4.94 ft ³ (0.14 m ³)	4.64 ft ³ (0.13 m ³)
Center of Gravity:	20.0" (507mm)	19.5" (494mm)	Center of Gravity:	13.9" (352mm)	13.3" (339mm)

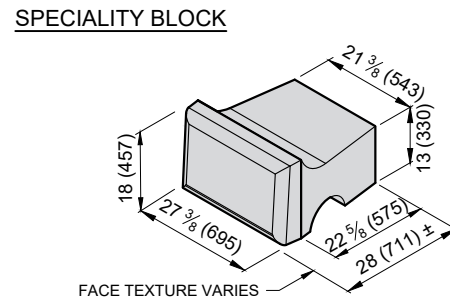
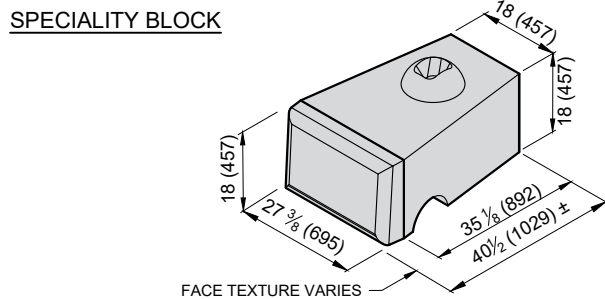

- Units for dimensions are inches (mm), typical unless noted otherwise.
- Block production varies with each licensed Redi-Rock manufacturer. Confirm availability before Specifying or Ordering.
- Center of Gravity is measured from the back of block.
- Actual block volumes and weights may vary.
- Weights are based upon a concrete density of 143 lb/ft³ (2291kg/m³).
- 27" (695) wide blocks contain a fork slot on only one side of the block. These are speciality blocks and may have limited availability and is only used in double 90 degree corner applications.
- Interface Shear knobs are typically 10" (254mm) diameter by 4" (102 mm) tall. Smaller knob diameters are available.

RETAINING BLOCKS

Block Library

R-28SDT		9" (230 mm) STEPDOWN TOP		R-41SDT	
Face Texture:	Cobble / Limestone	Kingstone / Ledgestone	Face Texture:	Cobble / Limestone	Kingstone / Ledgestone
Block Weight:	600 lb (270 kg)	500 lb (230 kg)	Block Weight:	840 lb (380 kg)	740 lb (340 kg)
Block Volume:	4.2 ft ³ (0.12 m ³)	3.4 ft ³ (0.10 m ³)	Block Volume:	5.9 ft ³ (0.17 m ³)	5.1 ft ³ (0.14 m ³)

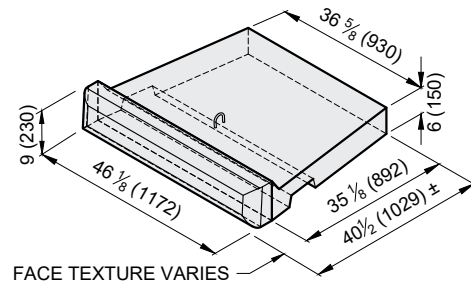
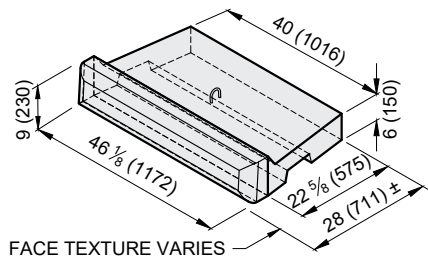

1. Units for dimensions are inches (mm), typical unless noted otherwise.
2. Block production varies with each licensed Redi-Rock manufacturer. Confirm availability before Specifying or Ordering.
3. Architectural faces on the blocks have varying texture.
4. Actual block volumes and weights may vary.
5. Weights are based upon a concrete density of 143 lb/ft³ (2291 kg/m³).

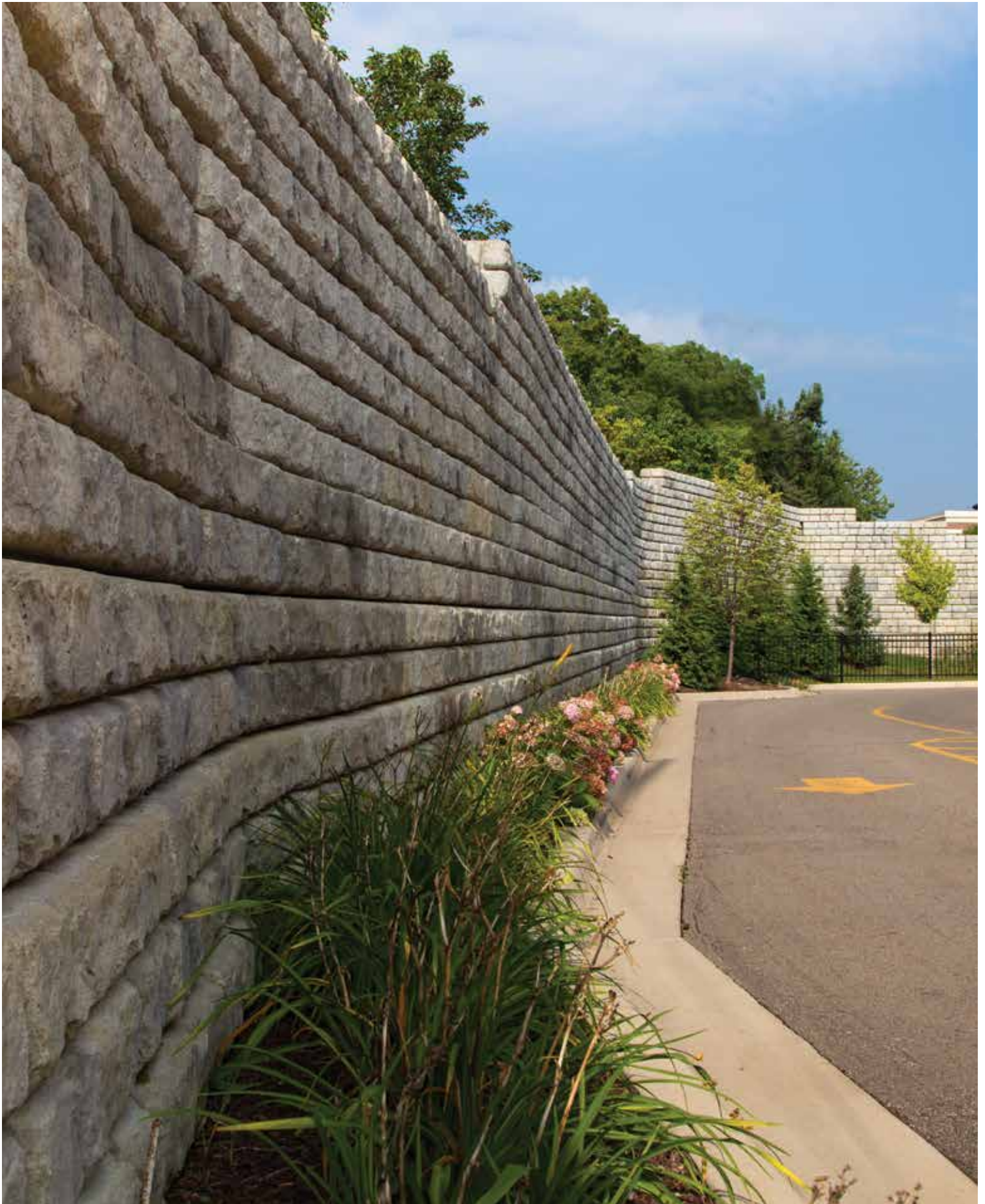

FREESTANDING BLOCKS (FINISHED TEXTURE ON MORE THAN ONE FACE)

The Redi-Rock Freestanding blocks come in one width and stack in a vertical manner. The defining characteristic is that freestanding blocks have an aesthetic texture cast into multiple faces; the textured face is on at least the two longitudinal vertical faces, and also as required on one end or the top of the blocks. These blocks are machine-placed, wet-cast, precast modular block units manufactured from first purpose, non-reconstituted concrete and intended for constructing dry-stacked modular retaining wall systems. The block units are manufactured from structural-grade concrete mixes in accordance with ASTM C94 or ASTM C685 that produce a finished unit with excellent resistance to freeze-thaw, deicing chemical exposure, and submerged conditions in both fresh water and salt water applications. All Redi-Rock blocks are manufactured and distributed through an international network of individually-owned, licensed precast concrete manufacturers.

CONCRETE MIX PROPERTIES ⁽¹⁾

FREEZE THAW EXPOSURE CLASS ⁽²⁾	MINIMUM 28 DAY COMPRESSIVE STRENGTH ⁽³⁾	MAXIMUM WATER CEMENT RATIO	NOMINAL MAXIMUM AGGREGATE SIZE ⁽¹⁰⁾	AGGREGATE CLASS DESIGNATION ⁽⁴⁾	AIR CONTENT ⁽⁵⁾
MODERATE	4,000 psi (27.6 MPa)	0.45	1.0 (25)	3M	4.5% ± 1.5%
SEVERE	4,000 psi (27.6 MPa)	0.45	1.0 (25)	3S	6.0% ± 1.5%
VERY SEVERE	4,500 psi (30.0 MPa)	0.40	1.0 (25)	4S	6.0% ± 1.5%
MAXIMUM WATER-SOLUBLE CHLORIDE ION (Cl ⁻) CONTENT IN CONCRETE, PERCENT BY WEIGHT OF CEMENT ^(6,7)					0.15
MAXIMUM CHLORIDE AS Cl ⁻ CONCENTRATION IN MIXING WATER, PARTS PER MILLION					1000
MAXIMUM PERCENTAGE OF TOTAL CEMENTITIOUS MATERIALS BY WEIGHT ^(8,10) (VERY SEVERE EXPOSURE CLASS ONLY)					
FLY ASH OR OTHER POZZOLANS PER ASTM C618		25	TOTAL ASH, POZZOLANS, SLAG, AND SILICA FUME ⁽⁹⁾		50
SLAG CONFORMING TO ASTM C989		50	TOTAL ASH, POZZOLANS, AND SILICA FUME ⁽⁹⁾		35
SILICA FUME CONFORMING TO ASTM C1240		10	ALKALI-AGGREGATE REACTIVITY MITIGATION PER ACI 201		

REFERENCE DIMENSIONS:

HEIGHT = VERTICAL DIMENSION OF TEXTURED FACE
 LENGTH = LONGER HORIZONTAL DIMENSION PARALLEL TO TEXTURED FACES
 WIDTH = HORIZONTAL DIMENSION PERPENDICULAR TO LONGER TEXTURED FACES

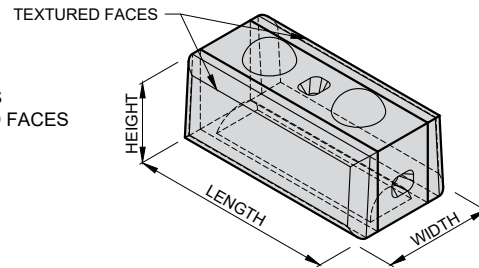

DIMENSIONAL TOLERANCES ^{(11) (12)}

HEIGHT	ALL BLOCKS	18 ± 3/16 (457 ± 5)
LENGTH	FULL BLOCKS	46 1/8 ± 1/2 (1172 ± 13)
	HALF BLOCKS	22 3/16 ± 1/2 (579 ± 13)
WIDTH	23 -24 (584-610)	13 ± 1/2 (330 ± 13) FORM LINE TO FORM LINE, PLUS APPROX. 5/8 (136) FACE TEXTURE ON LONG SIDES

- ⁽¹⁾ Concrete mix properties are in general accordance with ACI 318 durability requirements. Research has shown that concrete manufactured to these standards demonstrates good durability and performance. When these requirements are followed, specific freeze-thaw testing of the concrete is typically NOT required.
- ⁽²⁾ Exposure class is as described in ACI 318.
- ⁽³⁾ Test method ASTM C39.
- ⁽⁴⁾ Defined in ASTM C33 Table 3 *Limits for Deleterious Substances and Physical Property Requirements of Coarse Aggregate for Concrete*.
- ⁽⁵⁾ Test method ASTM C231.
- ⁽⁶⁾ Test method ASTM C1218 at age between 28 and 42 days.
- ⁽⁷⁾ Where used in high sulfate environments or where alkali-silica reactivity is an issue, water-soluble chloride shall be limited to no more than trace amounts (from impurities in concrete-making components, not intended constituents.)
- ⁽⁸⁾ The total cementitious material also includes ASTM C150, C595, C845, and C1157 cement. The maximum percentages shall include:
 - (a) Fly ash or other pozzolans in type IP, blended cement, ASTM C595, or ASTM C1157.
 - (b) Slag used in the manufacture of an IS blended cement, ASTM C595, or ASTM C1157.
 - (c) Silica fume, ASTM C1240, present in a blended cement.
- ⁽⁹⁾ Fly ash or other pozzolans and silica fume shall constitute no more than 25 and 10 percent, respectively, of the total weight of the cementitious materials.
- ⁽¹⁰⁾ Prescriptive limits shown may be waived for concrete mixes that demonstrate excellent freeze-thaw durability in a detailed and current testing program.
- ⁽¹¹⁾ All dimensions are shown in units of *inches (mm)*.
- ⁽¹²⁾ Permissible defects: Chips smaller than 1.5 (38) in its largest dimension and cracks not wider than 0.012 (0.305) and not longer than 25% of the nominal height of the block; bug holes in the architectural face smaller than 0.75 (19); and bug holes, water marks, and color variation on non-architectural faces.

FREESTANDING BLOCKS

Block Library

F-SM STRAIGHT MIDDLE

Face Texture:	Cobble / Limestone	Kingstone / Ledgestone
Block Weight:	1410 lb (640 kg)	1260 lb (570 kg)
Block Volume:	9.84 ft ³ (0.279 m ³)	8.84 ft ³ (0.250 m ³)

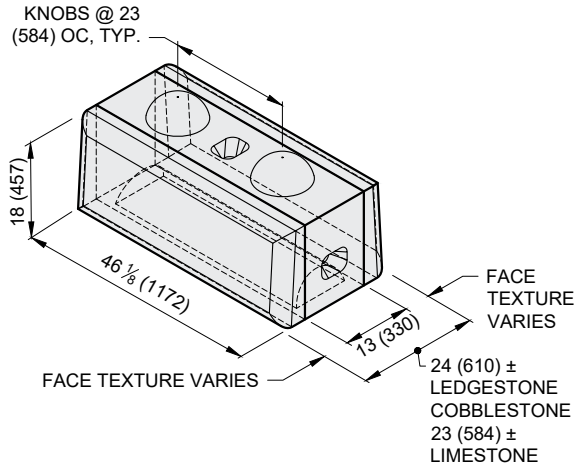

F-SG STRAIGHT GARDEN TOP

Face Texture:	Cobble / Limestone	Kingstone / Ledgestone
Block Weight:	1050 lb (480 kg)	910 lb (410 kg)
Block Volume:	7.35 ft ³ (0.208 m ³)	6.35 ft ³ (0.180 m ³)

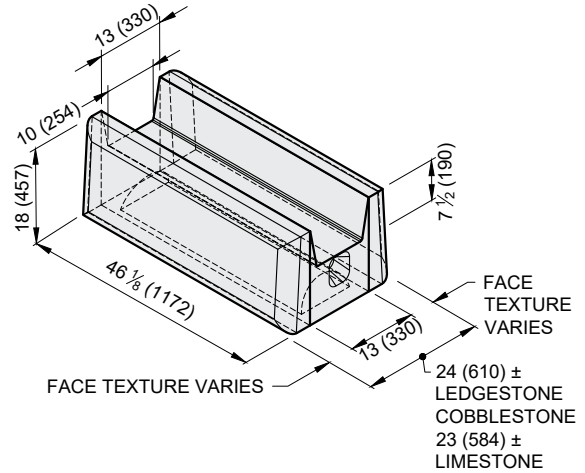

F-SB STRAIGHT BOTTOM

Face Texture:	Cobble / Limestone	Kingstone / Ledgestone
Block Weight:	1520 lb (690 kg)	1380 lb (630 kg)
Block Volume:	10.65 ft ³ (0.302 m ³)	9.66 ft ³ (0.273 m ³)

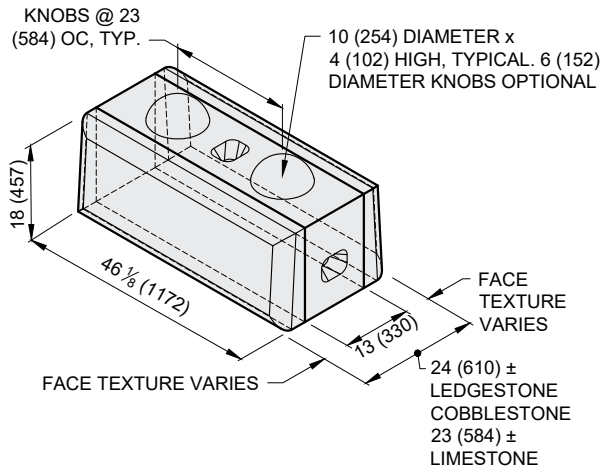

F-ST STRAIGHT TOP

Face Texture:	Cobble / Limestone	Kingstone / Ledgestone
Block Weight:	1380 lb (620 kg)	1230 lb (560 kg)
Block Volume:	9.61 ft ³ (0.272 m ³)	8.62 ft ³ (0.244 m ³)

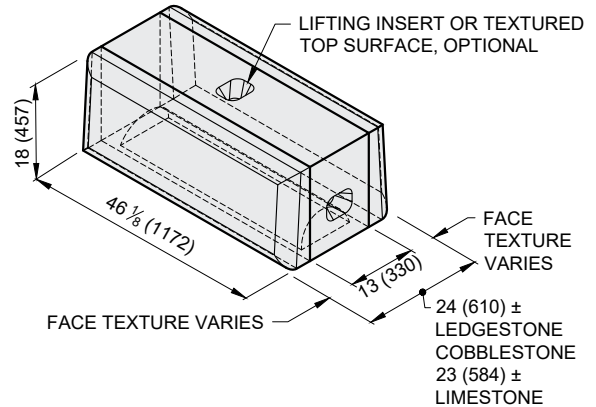

1. Units for dimensions are inches (mm), typical unless noted otherwise.
2. Block production varies with each licensed Redi-Rock manufacturer. Confirm availability before Specifying or Ordering.
3. Architectural faces on the blocks have varying texture.
4. Actual block volumes and weights may vary.

5. Weights are based upon a concrete density of 143 lb/ft³ (2291 kg/m³).
6. 6" (152 mm) diameter vertical semi-cylindrical voids at the ends of the block for mechanical tie-down are available, refer to Force Protection blocks for additional information.
7. Knobs are typically 10" (254mm) diameter by 4" (102 mm) tall. Smaller knobs are available.

FREESTANDING BLOCKS

Block Library

F-VM VARIABLE RADIUS MIDDLE

Face Texture:	Cobble / Limestone	Kingstone / Ledgestone
Block Weight:	1270 lb (570 kg)	1120 lb (510 kg)
Block Volume:	8.86 ft ³ (0.251 m ³)	7.86 ft ³ (0.223 m ³)

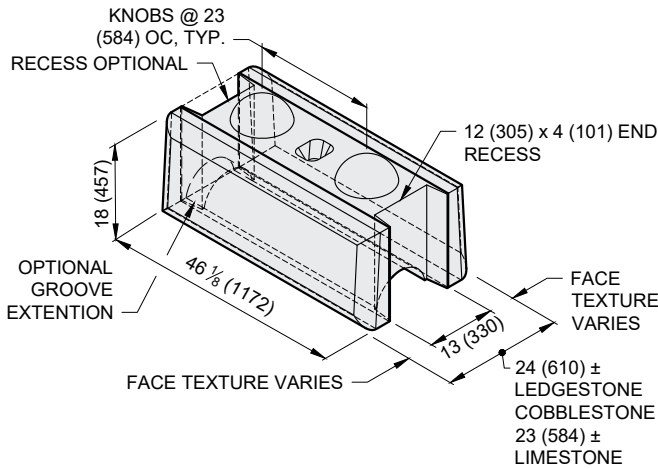

F-VG VARIABLE RADIUS GARDEN TOP

Face Texture:	Cobble / Limestone	Kingstone / Ledgestone
Block Weight:	970 lb (440 kg)	820 lb (370 kg)
Block Volume:	6.76 ft ³ (0.191 m ³)	5.76 ft ³ (0.163 m ³)

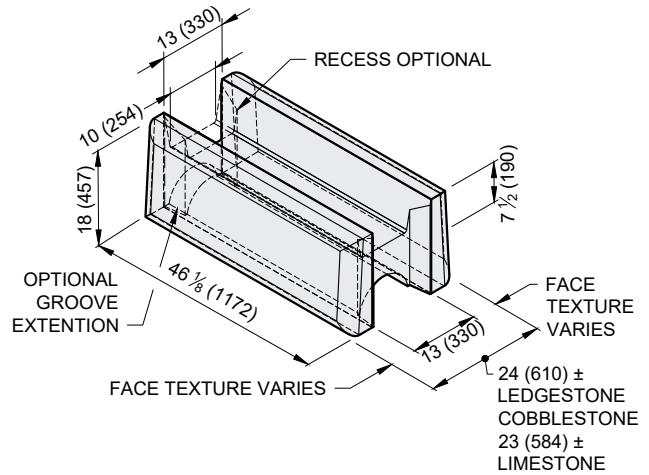

F-VB VARIABLE RADIUS BOTTOM

Face Texture:	Cobble / Limestone	Kingstone / Ledgestone
Block Weight:	1380 lb (630 kg)	1240 lb (560 kg)
Block Volume:	9.65 ft ³ (0.273 m ³)	8.66 ft ³ (0.245 m ³)

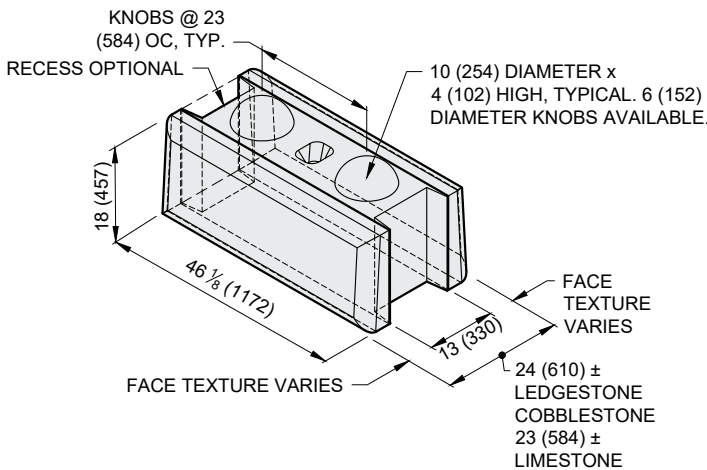

F-VT VARIABLE RADIUS TOP

Face Texture:	Cobble / Limestone	Kingstone / Ledgestone
Block Weight:	1240 lb (560 kg)	1090 lb (500 kg)
Block Volume:	8.63 ft ³ (0.244 m ³)	7.64 ft ³ (0.216 m ³)

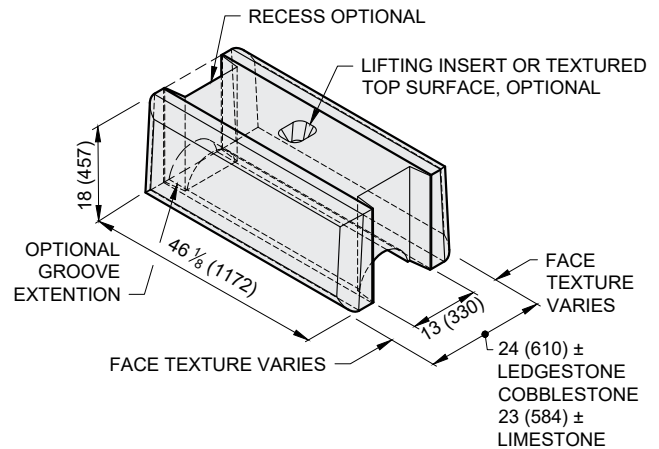

- Units for dimensions are inches (mm), typical unless noted otherwise.
- Block production varies with each licensed Redi-Rock manufacturer. Confirm availability before Specifying or Ordering.
- Variable radius feature can be cast on only one end, coordinate.
- Architectural faces on the blocks have varying texture.
- Actual block volumes and weights may vary.
- Weights are based upon a concrete density of 143 lb/ft³ (2291 kg/m³).
- Knobs are typically 10" (254 mm) diameter by 4" (102 mm) tall. Smaller knobs are available.

FREESTANDING BLOCKS

Block Library

F-FM	FORCE PROTECTION MIDDLE		F-FT	FORCE PROTECTION TOP	
Face Texture:	Cobble / Limestone	Kingstone / Ledgestone	Face Texture:	Cobble / Limestone	Kingstone / Ledgestone
Block Weight:	1350 lb (610 kg)	1200 lb (550 kg)	Block Weight:	1310 lb (600 kg)	1170 lb (530 kg)
Block Volume:	9.41 ft ³ (0.267 m ³)	8.42 ft ³ (0.238 m ³)	Block Volume:	9.19 ft ³ (0.260 m ³)	8.19 ft ³ (0.232 m ³)

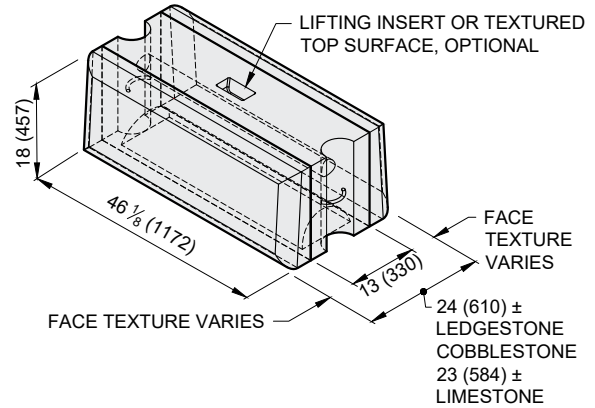
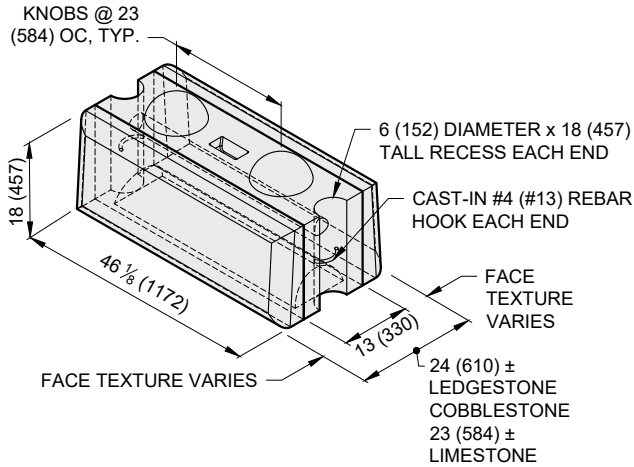

F-FB	FORCE PROTECTION BOTTOM		F-BB	BARRIER BLOCK	
Face Texture:	Cobble / Limestone	Kingstone / Ledgestone	Block Weight:	9,350 lb (4,240 kg)	
Block Weight:	1460 lb (660 kg)	1320 lb (600 kg)	Block Volume:	65.4 ft ³ (1.85 m ³)	
Block Volume:	10.23 ft ³ (0.290 m ³)	9.23 ft ³ (0.261 m ³)			

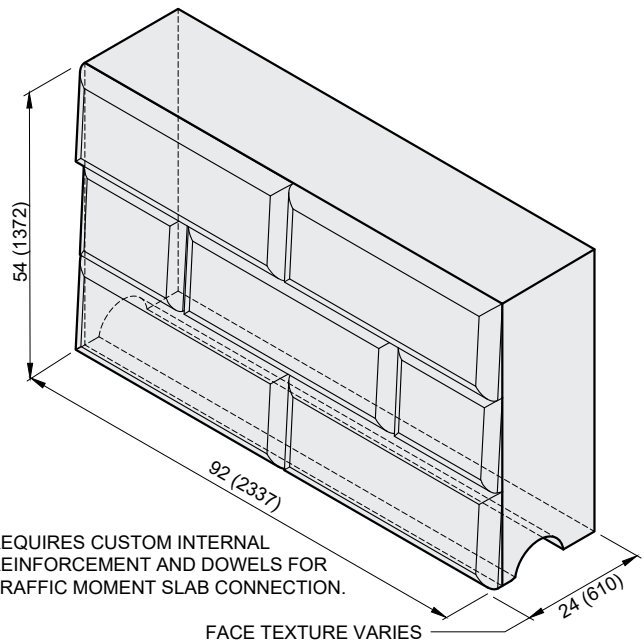
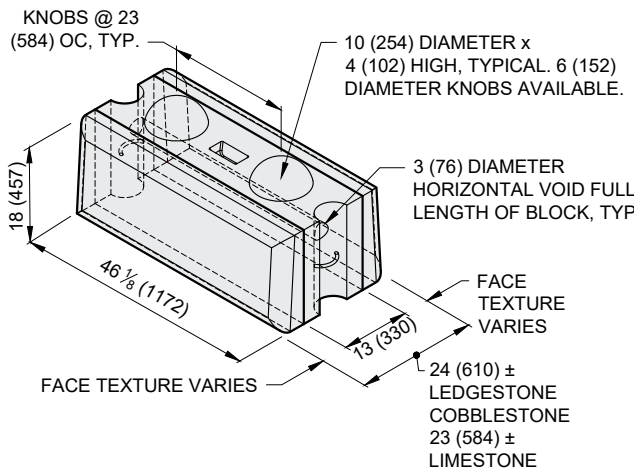

- Units for dimensions are inches (mm), typical unless noted otherwise.
- Block production varies with each licensed Redi-Rock manufacturer. Confirm availability before Specifying or Ordering.
- Architectural faces on the blocks have varying texture.
- Actual block volumes and weights may vary.
- Weights are based upon a concrete density of 143 lb/ft³ (2291 kg/m³).
- Knobs are typically 10" (254mm) diameter by 4" (102 mm) tall. Smaller knobs are available.

FREESTANDING BLOCKS

Block Library

F-CM CORNER MIDDLE			F-CG CORNER GARDEN TOP		
Face Texture:	Cobble / Limestone	Kingstone / Ledgestone	Face Texture:	Cobble / Limestone	Kingstone / Ledgestone
Block Weight:	1370 lb (620 kg)	1360 lb (620 kg)	Block Weight:	1070 lb (480 kg)	1060 lb (480 kg)
Block Volume:	9.6 ft ³ (0.27m ³)	9.5 ft ³ (0.27m ³)	Block Volume:	7.5 ft ³ (0.21m ³)	7.4 ft ³ (0.21m ³)

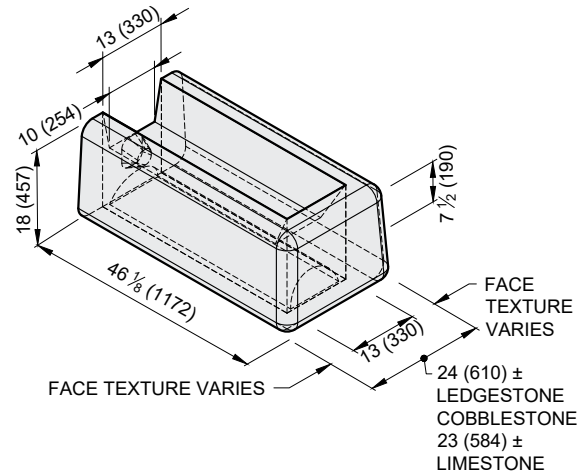
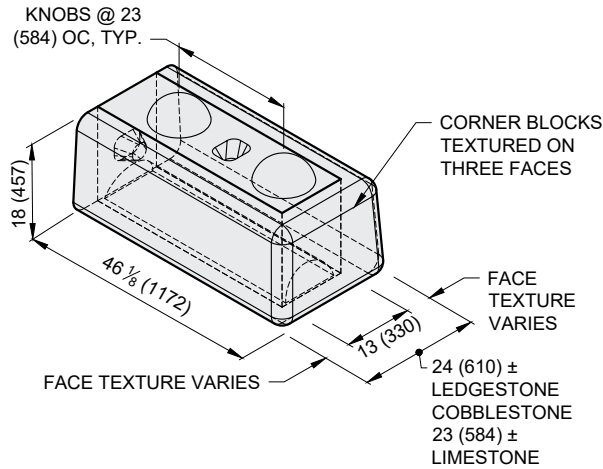

F-CB CORNER BOTTOM			F-CT CORNER TOP		
Face Texture:	Cobble / Limestone	Kingstone / Ledgestone	Face Texture:	Cobble / Limestone	Kingstone / Ledgestone
Block Weight:	1490 lb (680 kg)	1480 lb (670 kg)	Block Weight:	1340 lb (610 kg)	1330 lb (600 kg)
Block Volume:	10.4 ft ³ (0.30m ³)	10.3 ft ³ (0.29m ³)	Block Volume:	9.4 ft ³ (0.26m ³)	9.3 ft ³ (0.26m ³)

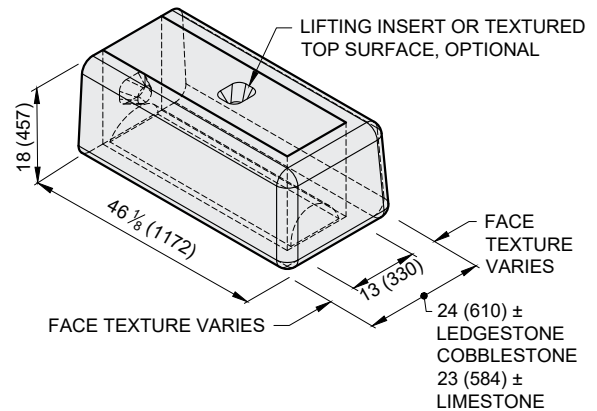
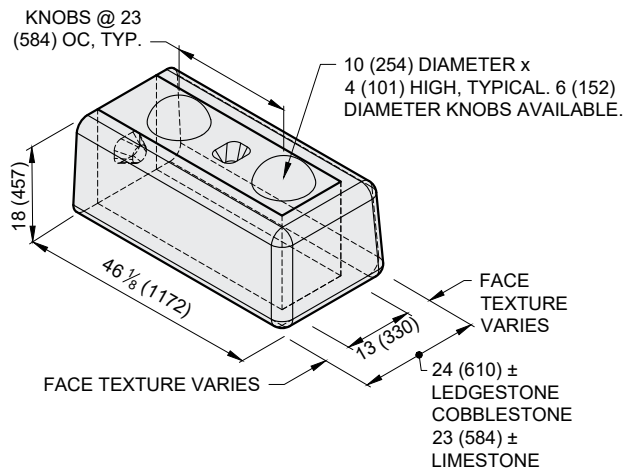

1. Units for dimensions are inches (mm), typical unless noted otherwise.
2. Block production varies with each licensed Redi-Rock manufacturer. Confirm availability before Specifying or Ordering.
3. Architectural faces on the blocks have varying texture.
4. Actual block volumes and weights may vary.
5. Weights are based upon a concrete density of 143 lb/ft³ (2291 kg/m³).
6. Knobs are typically 10" (254mm) diameter by 4" (102 mm) tall. Smaller knobs are available.

FREESTANDING BLOCKS

Block Library

F-HCM HALF CORNER MIDDLE			F-HCG HALF CORNER GARDEN TOP		
Face Texture:	Cobble / Limestone	Kingstone / Ledgestone	Face Texture:	Cobble / Limestone	Kingstone / Ledgestone
Block Weight:	660 lb (300 kg)	650 lb (300 kg)	Block Weight:	530 lb (240 kg)	530 lb (240 kg)
Block Volume:	4.6 ft ³ (0.13m ³)	4.6 ft ³ (0.13m ³)	Block Volume:	3.7 ft ³ (0.11m ³)	3.7 ft ³ (0.10m ³)

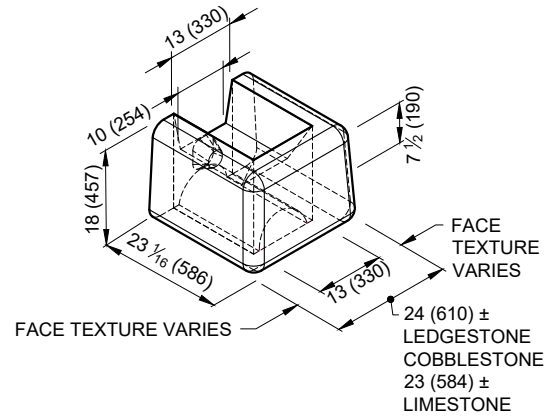
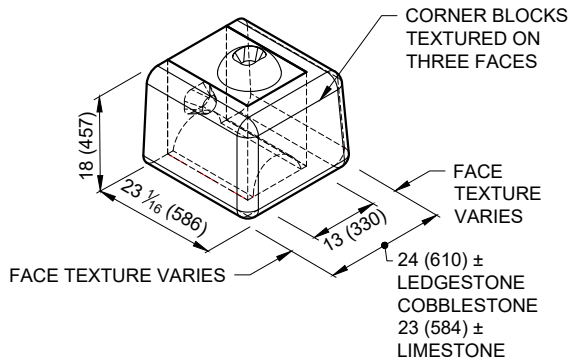

F-HCB HALF CORNER BOTTOM			F-HCT HALF CORNER TOP		
Face Texture:	Cobble / Limestone	Kingstone / Ledgestone	Face Texture:	Cobble / Limestone	Kingstone / Ledgestone
Block Weight:	710 lb (320 kg)	700 lb (320 kg)	Block Weight:	640 lb (290 kg)	630 lb (290 kg)
Block Volume:	5.0 ft ³ (0.14m ³)	4.9 ft ³ (0.14m ³)	Block Volume:	4.5 ft ³ (0.13m ³)	4.4 ft ³ (0.13m ³)

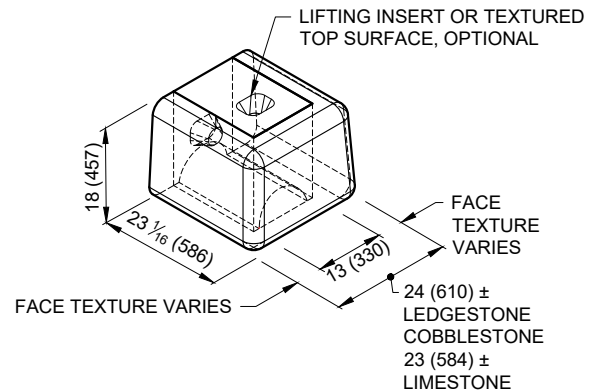
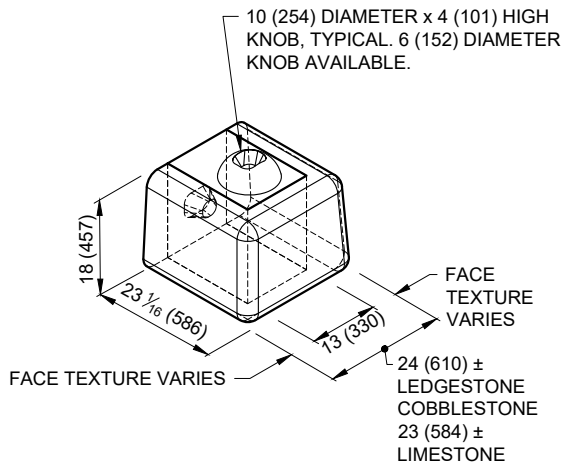

- Units for dimensions are inches (mm), typical unless noted otherwise.
- Block production varies with each licensed Redi-Rock manufacturer. Confirm availability before Specifying or Ordering.
- Architectural faces on the blocks have varying texture.
- Actual block volumes and weights may vary.
- Weights are based upon a concrete density of 143 lb/ft³ (2291 kg/m³).
- Knobs are typically 10" (254mm) diameter by 4" (102 mm) tall. Smaller knobs are available.

FREESTANDING BLOCKS

Block Library

F-HC HOLLOW-CORE

Face Texture:	Cobble / Limestone	Kingstone / Ledgestone
Block Weight:	910 lb (410 kg)	770 lb (350 kg)
Block Volume:	6.38 ft ³ (0.181 m ³)	5.38 ft ³ (0.152 m ³)
Infill Volume:	4.09 ft ³ (0.116 m ³)	

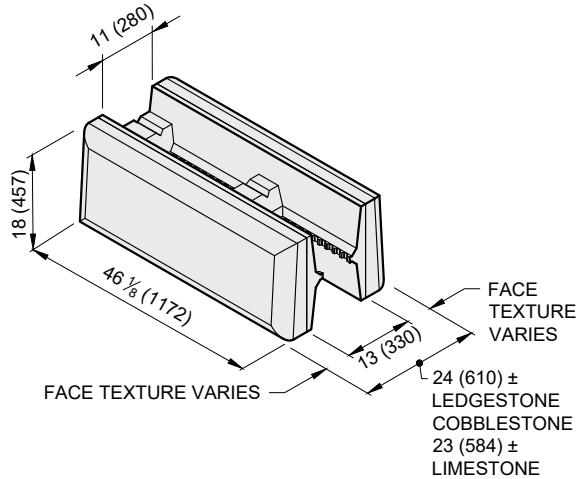

F-CHC CORNER HOLLOW-CORE

Face Texture:	Cobble / Limestone	Kingstone / Ledgestone
Block Weight:	1000 lb (460 kg)	970 lb (440 kg)
Block Volume:	7.01 ft ³ (0.198 m ³)	6.80 ft ³ (0.192 m ³)
Infill Volume:	3.37 ft ³ (0.095 m ³)	

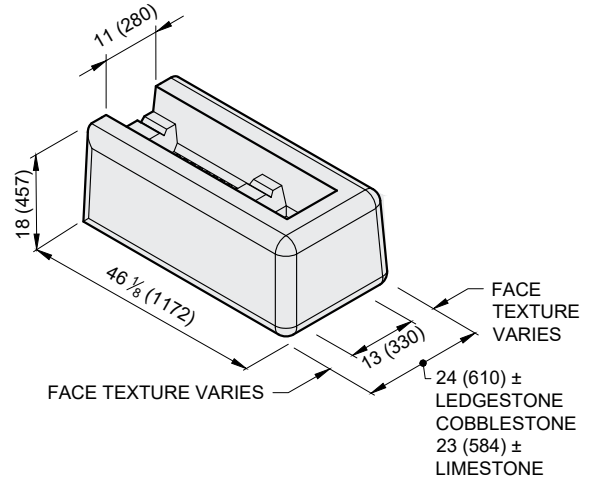

F-HHC HALF HOLLOW-CORE

Face Texture:	Cobble / Limestone	Kingstone / Ledgestone
Block Weight:	460 lb (210 kg)	390 lb (180 kg)
Block Volume:	3.19 ft ³ (0.090 m ³)	2.69 ft ³ (0.076 m ³)
Infill Volume:	2.04 ft ³ (0.058 m ³)	

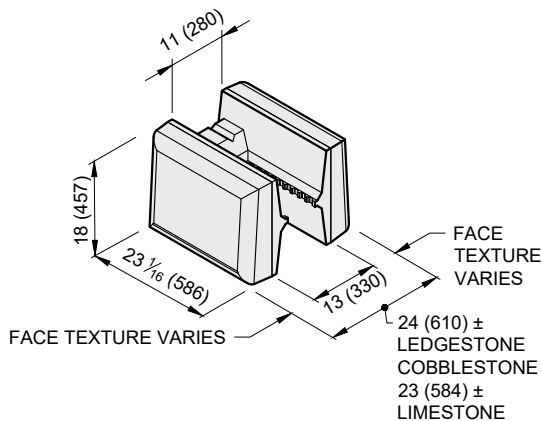

F-HCHC HALF CORNER HOLLOW-CORE

Face Texture:	Cobble / Limestone	Kingstone / Ledgestone
Block Weight:	550 lb (250 kg)	510 lb (230 kg)
Block Volume:	3.81 ft ³ (0.108 m ³)	3.53 ft ³ (0.100 m ³)
Infill Volume:	1.31 ft ³ (0.037 m ³)	

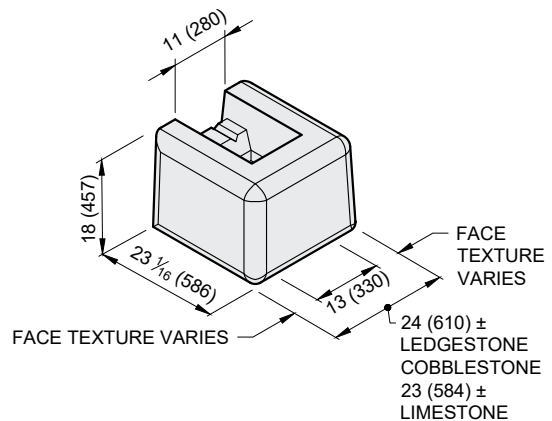

1. Units for dimensions are inches (mm), typical unless noted otherwise.
2. Confirm block production with licensed Redi-Rock manufacturer.
3. Architectural faces on the blocks have varying texture.
4. Average block weights shown. Actual block volumes and weights may vary.
5. Weights are based upon a concrete density of 143 lb/ft³ (2291 kg/m³).

FREESTANDING BLOCKS

Block Library

F-9SC 9" (230) STEPDOWN CORNER

Face Texture:	Cobble / Limestone	Kingstone / Ledgestone
Block Weight:	740 lb (340 kg)	660 lb (300 kg)
Block Volume:	5.17 ft ³ (0.146 m ³)	4.60 ft ³ (0.130 m ³)

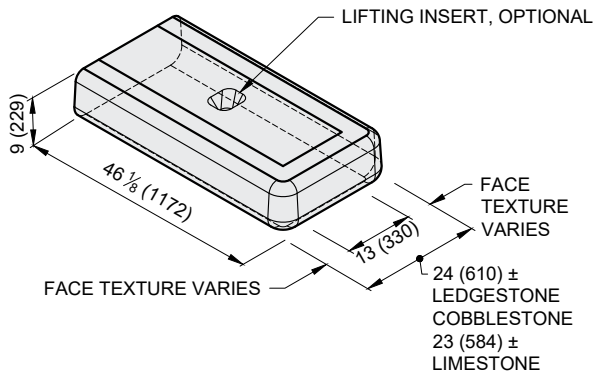

F-9SG 9" (230) STEPDOWN GARDEN

Face Texture:	Cobble / Limestone	Kingstone / Ledgestone
Block Weight:	550 lb (250 kg)	470 lb (210 kg)
Block Volume:	3.86 ft ³ (0.109 m ³)	3.30 ft ³ (0.093 m ³)

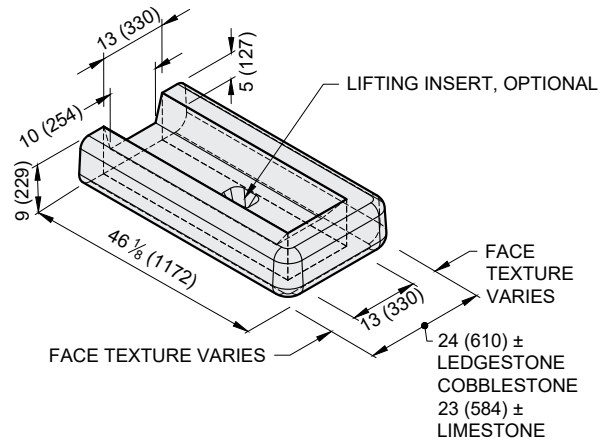

F-90C 90 DEGREE CORNER

Face Texture:	Cobble / Limestone	Kingstone / Ledgestone
Block Weight:	1330 lb (600 kg)	1320 lb (600 kg)
Block Volume:	9.3 ft ³ (0.26m ³)	9.2 ft ³ (0.26m ³)

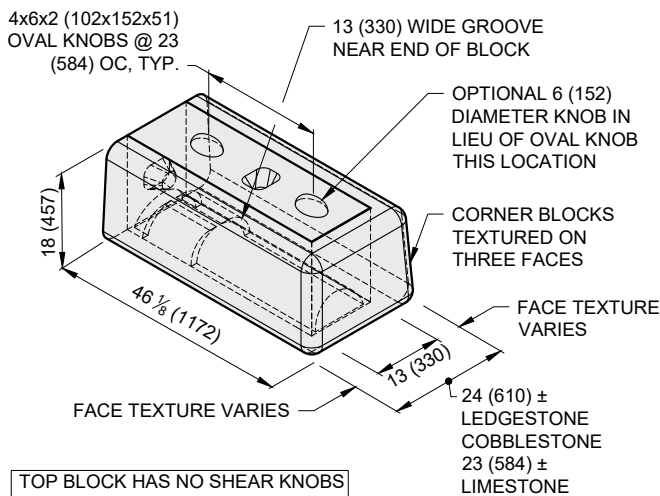

1. Units for dimensions are inches (mm), typical unless noted otherwise.
2. Block production varies with each licensed Redi-Rock manufacturer. Confirm availability before Specifying or Ordering.

3. Architectural faces on the blocks have varying texture.
4. Actual block volumes and weights may vary.
5. Weights are based upon a concrete density of 143 lb/ft³ (2291 kg/m³).



ACCESSORY BLOCKS (COLUMNS, STEPS, AND CAPS)

The Redi-Rock Column and Accessory blocks come in multiple widths and configurations. The defining characteristic is that these blocks have an aesthetic texture cast into two or more faces, and create columns, caps, and steps that complement both Retaining and Freestanding blocks. These blocks are machine-placed, wet-cast, precast modular block units manufactured from first purpose, non-reconstituted concrete and intended for constructing dry-stacked modular features that coordinate with retaining walls. The block units are manufactured from structural-grade concrete mixes in accordance with ASTM C94 or ASTM C685 that produce a finished unit with excellent resistance to freeze-thaw, deicing chemical exposure, and submerged conditions in both fresh water and salt water applications. All Redi-Rock blocks are manufactured and distributed through an international network of individually-owned, licensed precast concrete manufacturers.

CONCRETE MIX PROPERTIES ⁽¹⁾

FREEZE THAW EXPOSURE CLASS ⁽²⁾	MINIMUM 28 DAY COMPRESSIVE STRENGTH ⁽³⁾	MAXIMUM WATER CEMENT RATIO	NOMINAL MAXIMUM AGGREGATE SIZE ⁽¹⁰⁾	AGGREGATE CLASS DESIGNATION ⁽⁴⁾	AIR CONTENT ⁽⁵⁾
MODERATE	4,000 psi (27.6 MPa)	0.45	1.0 (25)	3M	4.5% ± 1.5%
SEVERE	4,000 psi (27.6 MPa)	0.45	1.0 (25)	3S	6.0% ± 1.5%
VERY SEVERE	4,500 psi (30.0 MPa)	0.40	1.0 (25)	4S	6.0% ± 1.5%
MAXIMUM WATER-SOLUBLE CHLORIDE ION (Cl ⁻) CONTENT IN CONCRETE, PERCENT BY WEIGHT OF CEMENT ^(6,7)					0.15
MAXIMUM CHLORIDE AS Cl ⁻ CONCENTRATION IN MIXING WATER, PARTS PER MILLION					1000
MAXIMUM PERCENTAGE OF TOTAL CEMENTITIOUS MATERIALS BY WEIGHT ^(8,10) (VERY SEVERE EXPOSURE CLASS ONLY)					
FLY ASH OR OTHER POZZOLANS PER ASTM C618		25	TOTAL ASH, POZZOLANS, SLAG, AND SILICA FUME ⁽⁹⁾		50
SLAG CONFORMING TO ASTM C989		50	TOTAL ASH, POZZOLANS, AND SILICA FUME ⁽⁹⁾		35
SILICA FUME CONFORMING TO ASTM C1240		10	ALKALI-AGGREGATE REACTIVITY MITIGATION PER ACI 201		

REFERENCE DIMENSIONS:

HEIGHT = VERTICAL DIMENSION OF TEXTURED FACE
 LENGTH = LONGER HORIZONTAL DIMENSION OF TEXTURED FACE
 WIDTH = SHORTER HORIZONTAL DIMENSION

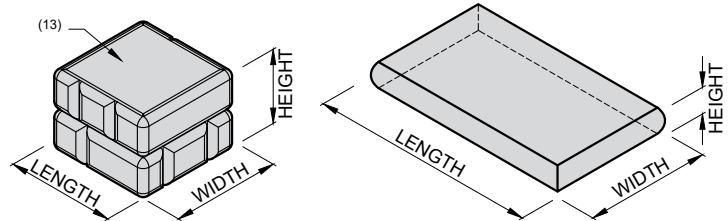

DIMENSIONAL TOLERANCES ⁽¹¹⁾⁽¹²⁾

COLUMN BLOCK

CAP/ STEP BLOCK

	COLUMN BLOCKS	CAP/ STEP BLOCKS
HEIGHT	18 ± 3/16 (457 ± 5)	6 ± 3/16 (152 ± 5)
LENGTH	24 ± 1/2 (610 ± 13)	VARIES ± 1/2 (VARIES ± 13)
WIDTH	24 ± 1/2 (610 ± 13)	28 1/2 ± 1/2 (724 ± 13)

⁽¹⁾ Concrete mix properties are in general accordance with ACI 318 durability requirements. Research has shown that concrete manufactured to these standards demonstrates good durability and performance. When these requirements are followed, specific freeze-thaw testing of the concrete is typically NOT required.

⁽²⁾ Exposure class is as described in ACI 318.

⁽³⁾ Test method ASTM C39.

⁽⁴⁾ Defined in ASTM C33 Table 3 *Limits for Deleterious Substances and Physical Property Requirements of Coarse Aggregate for Concrete*.

⁽⁵⁾ Test method ASTM C231.

⁽⁶⁾ Test method ASTM C1218 at age between 28 and 42 days.

⁽⁷⁾ Where used in high sulfate environments or where alkali-silica reactivity is an issue, water-soluble chloride shall be limited to no more than trace amounts (from impurities in concrete-making components, not intended constituents.)

⁽⁸⁾ The total cementitious material also includes ASTM C150, C595, C845, and C1157 cement. The maximum percentages shall include:

(a) Fly ash or other pozzolans in type IP, blended cement, ASTM C595, or ASTM C1157.

(b) Slag used in the manufacture of an IS blended cement, ASTM C595, or ASTM C1157.

(c) Silica fume, ASTM C1240, present in a blended cement.

⁽⁹⁾ Fly ash or other pozzolans and silica fume shall constitute no more than 25 and 10 percent, respectively, of the total weight of the cementitious materials.

⁽¹⁰⁾ Prescriptive limits shown may be waived for concrete mixes that demonstrate excellent freeze-thaw durability in a detailed and current testing program.

⁽¹¹⁾ All dimensions are shown in units of *inches (mm)*.

⁽¹²⁾ Permissible defects: Chips smaller than 1.5" (38mm) in its largest dimension and cracks not wider than 0.012" (0.305mm) and not longer than 25% of the nominal height of the block; bug holes in the architectural face smaller than 0.75" (19mm); and bug holes, water marks, and color variation on non-architectural faces.

⁽¹³⁾ Column blocks have a smooth troweled finish on horizontal faces.

ACCESSORIES (CAP AND STEP BLOCKS)

Block Library

A-2SC TWO-SIDED

Block Weight: 630 lb (290 kg)
 Block Volume: 4.42 ft³ (0.125 m³)

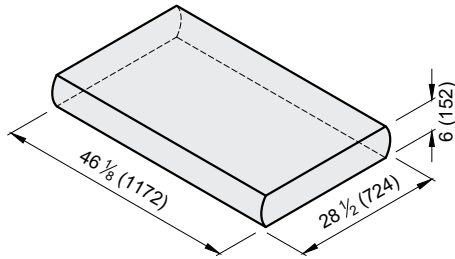

A-4SC FOUR-SIDED

Block Weight: 670 lb (300 kg)
 Block Volume: 4.65 ft³ (0.132 m³)

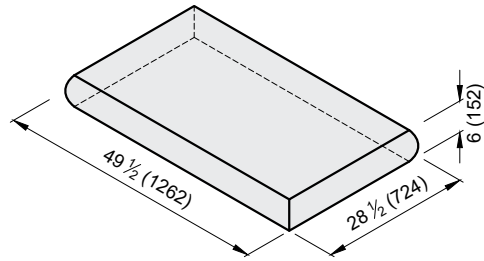

A-3SC72 THREE-SIDED 72"

Block Weight: 1040 lb (470 kg)
 Block Volume: 7.3 ft³ (0.21 m³)

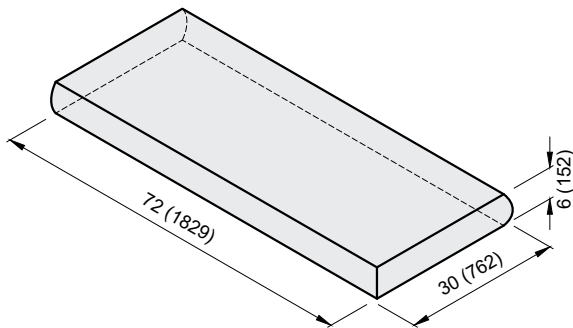

1. Units for dimensions are inches (mm), typical unless noted otherwise.
2. Block production varies with each licensed Redi-Rock manufacturer. Confirm availability before Specifying or Ordering.

3. Actual block volumes and weights may vary.
4. Weights are based upon a concrete density of 143 lb/ft³ (2291 kg/m³).

ACCESSORIES (COLUMN BLOCKS)

Block Library

A-COL8 COLUMN - 8" (203mm) CORE

Block Weight: 730 lb (330 kg)
 Block Volume: 5.1 ft³ (0.14 m³)

CENTERED THRU TAPERED HOLE
 8-10 (200-250) DIAMETERS

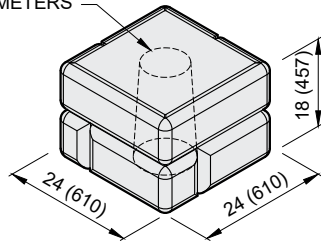

A-COL4 COLUMN - 4" (102mm) CORE

Block Weight: 810 lb (370 kg)
 Block Volume: 5.6 ft³ (0.16 m³)

CENTERED 4 (102) DIAMETER
 PVC PIPE SLEEVE THRU BLOCK

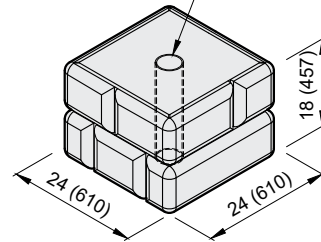

A-COLS COLUMN - SOLID CORE

Block Weight: 830 lb (380 kg)
 Block Volume: 5.8 ft³ (0.16 m³)

OPTIONAL FENCE POCKET

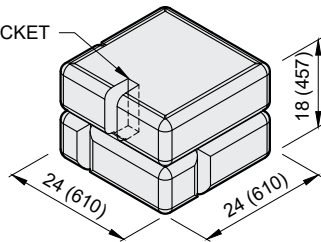

A-CC COLUMN CAP

Block Weight: 390 lb (180 kg)
 Block Volume: 2.7 ft³ (0.08 m³)

OPTIONAL 4 (102) DIAMETER
 THRU CENTER HOLE

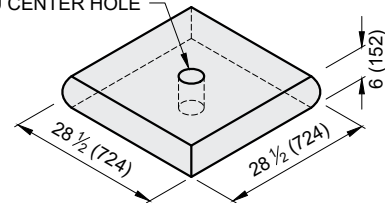

1. Units for dimensions are inches (mm), typical unless noted otherwise.
2. Block production varies with each licensed Redi-Rock manufacturer. Confirm availability before Specifying or Ordering.
3. Actual block volumes and weights may vary.

4. Weights are based upon a concrete density of 143 lb/ft³ (2291 kg/m³).
5. Weight and volume ranges represents the blocks with the maximum hole size shown and with no hole.
6. Optional fence rail pockets available upon request. Typical pocket size is: 2 (50) wide x 5 (130) deep x 9 (230) tall.





CONSTRUCTION DETAILS

Typical Gravity Wall Section

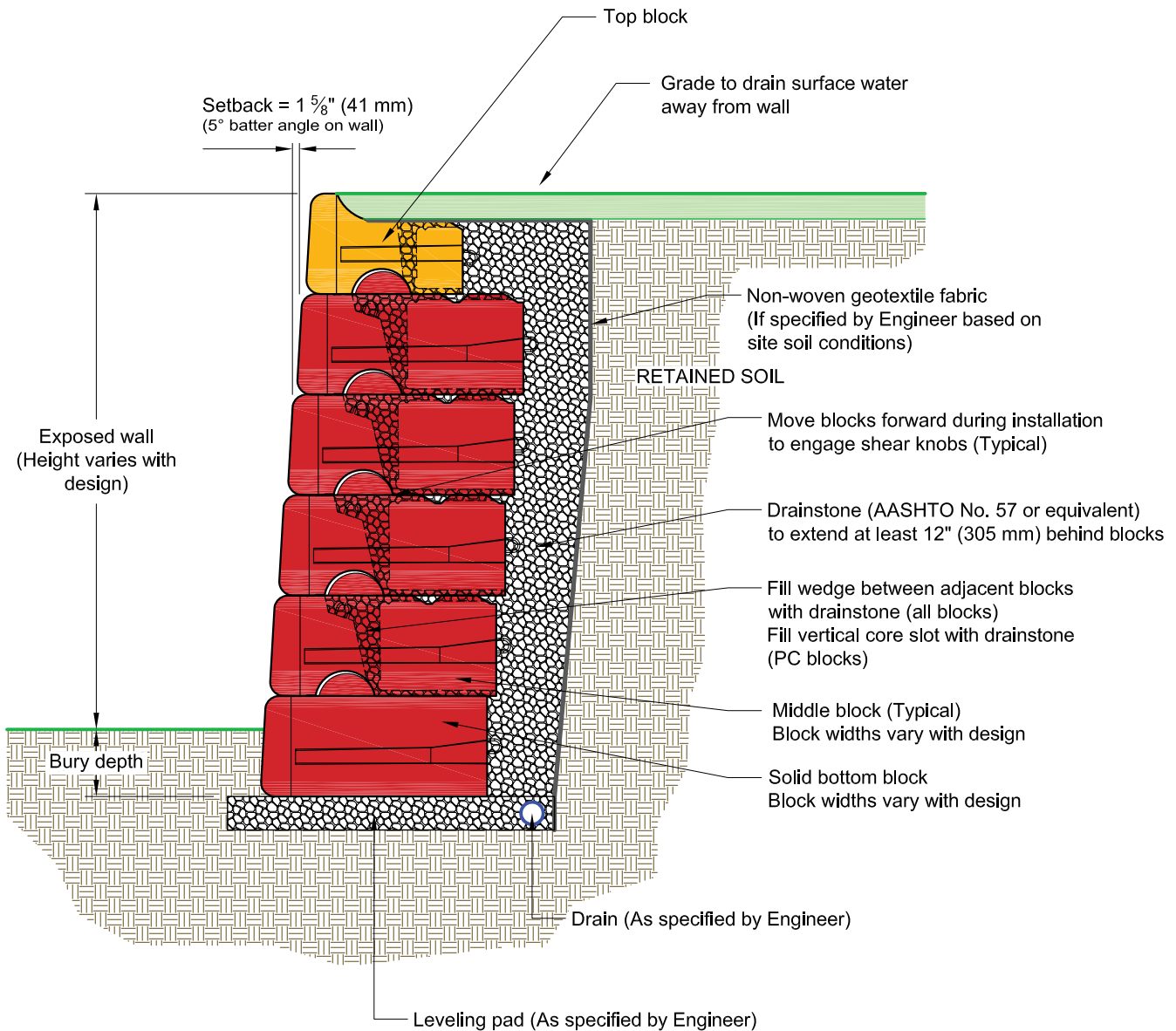

This drawing is for reference only. Determination of the suitability and/or manner of use of any details contained in this document is the sole responsibility of the design engineer of record. Final project designs, including all construction details, shall be prepared by a licensed professional engineer using the actual conditions of the proposed site.

Typical XL Gravity Wall Section

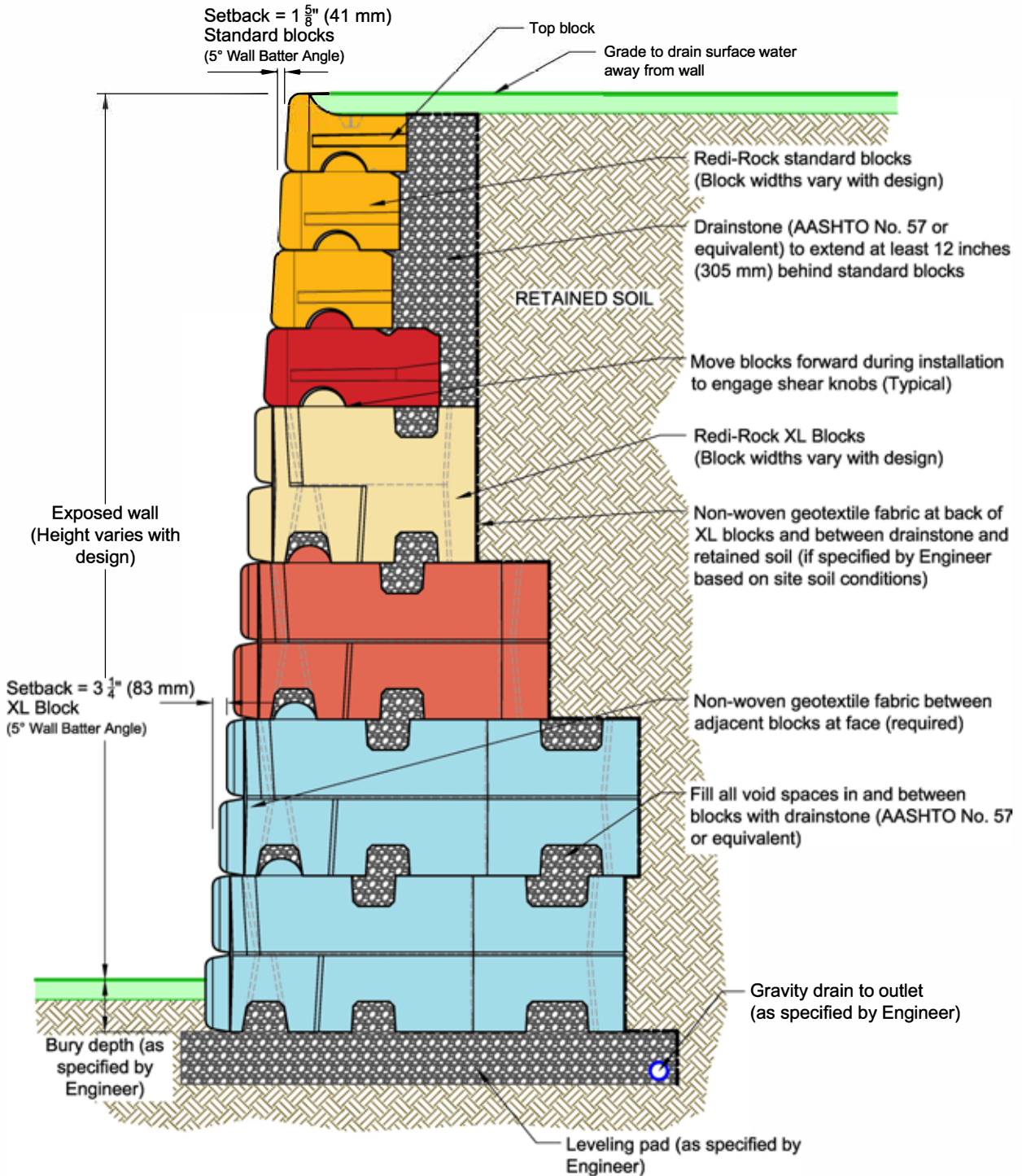

This drawing is for reference only. Determination of the suitability and/or manner of use of any details contained in this document is the sole responsibility of the design engineer of record. Final project designs, including all construction details, shall be prepared by a licensed professional engineer using the actual conditions of the proposed site.

Large Batter Wall Section

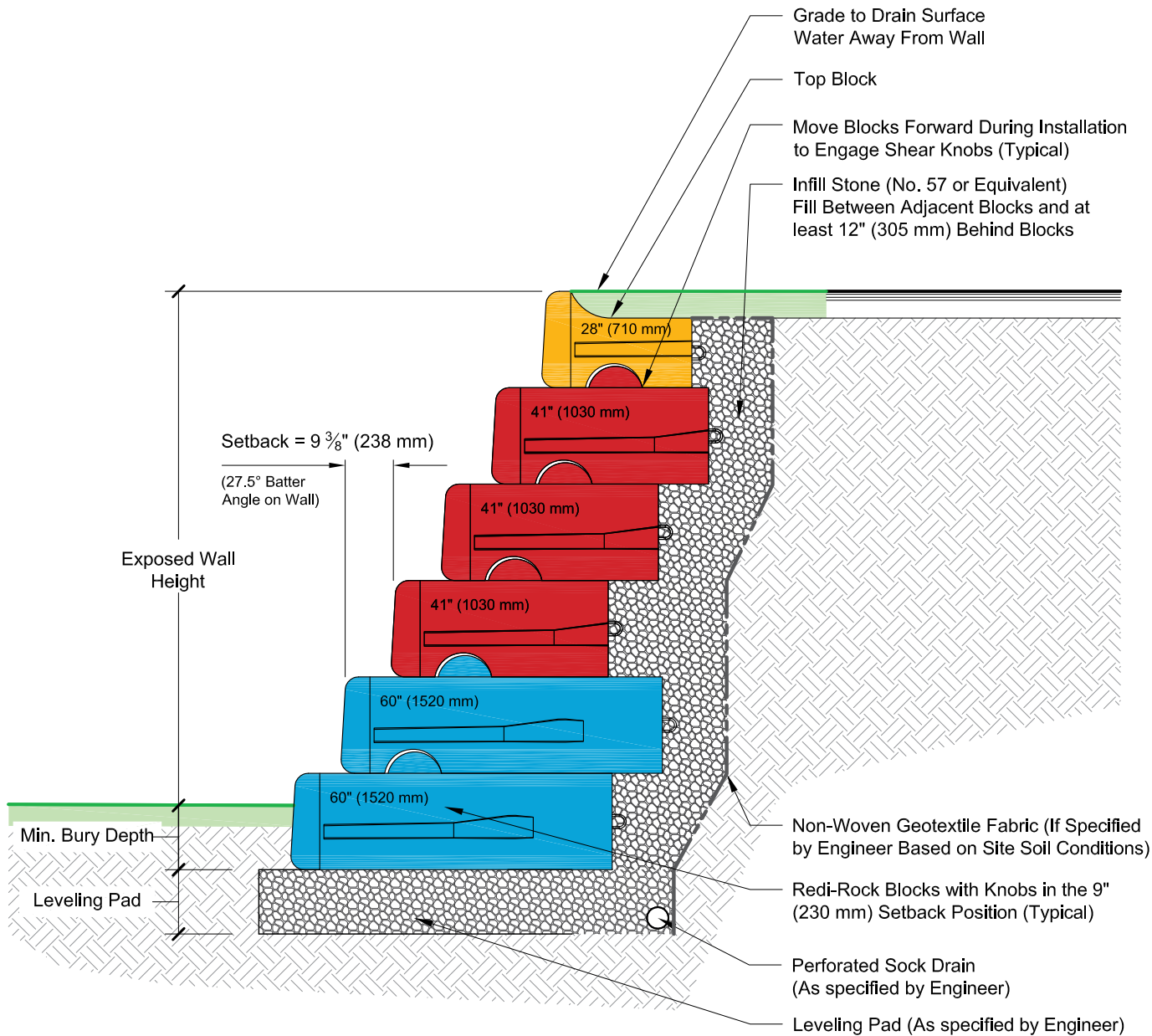

This drawing is for reference only. Determination of the suitability and/or manner of use of any details contained in this document is the sole responsibility of the design engineer of record. Final project designs, including all construction details, shall be prepared by a licensed professional engineer using the actual conditions of the proposed site. Final wall design must address both internal and external drainage and all modes of wall stability.

Alternating Planter & Standard Batter Wall Section

The Redi-Rock retaining blocks are available with multiple shear knob size and location options, to permit wall batter design flexibility. This detail depicts alternating $16\frac{5}{8}$ " (422 mm) Planter and $1\frac{5}{8}$ " (41 mm) Standard setback blocks, however designs are possible using more than one Standard setback block between Planter blocks. The regular repetition of combinations of different setback blocks within a wall profile can have structural and aesthetic significance. Abrupt changes in wall batter that carry over multiple blocks are not recommended.

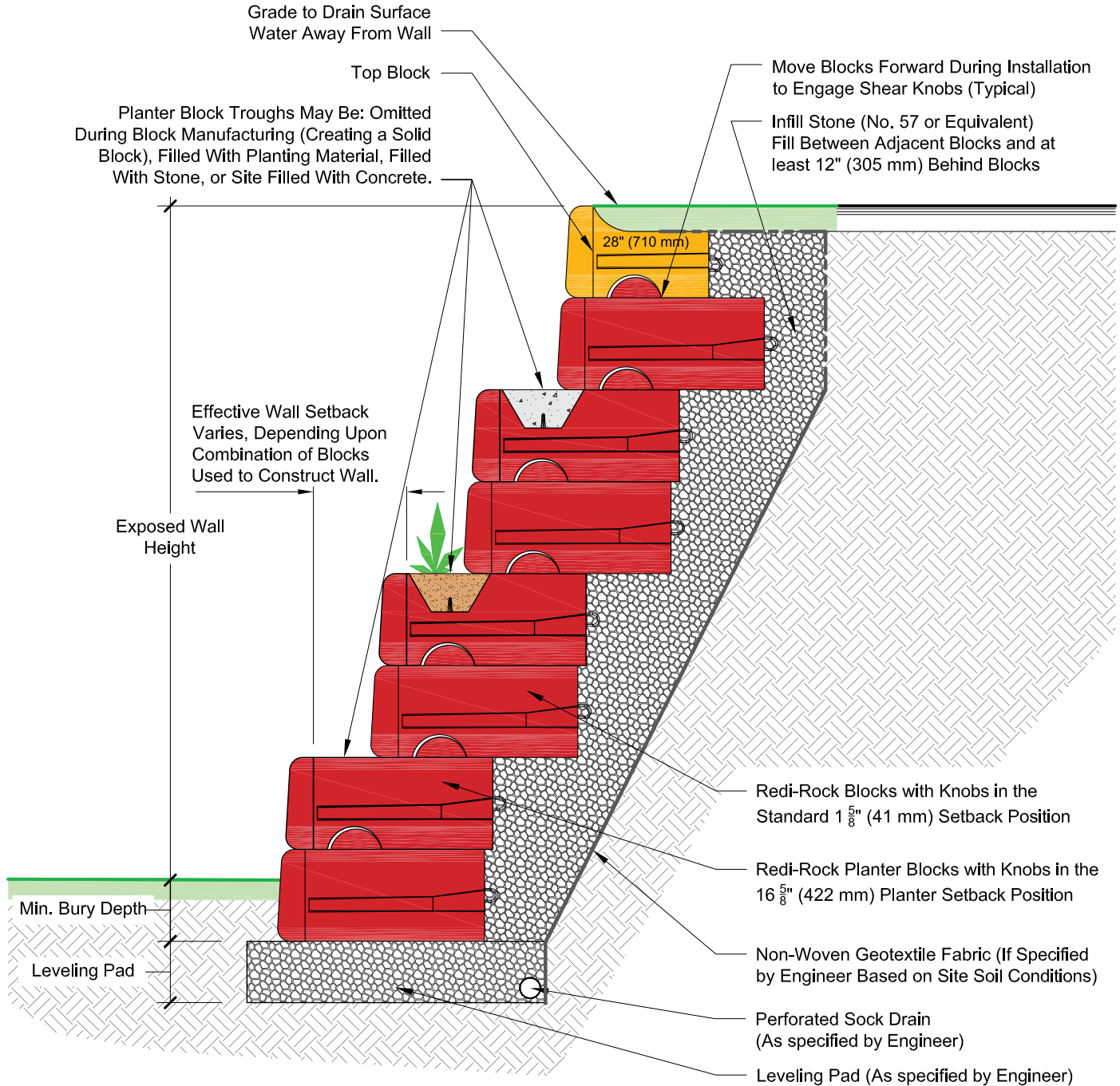

This drawing is for reference only. Determination of the suitability and/or manner of use of any details contained in this document is the sole responsibility of the design engineer of record. Final project designs, including all construction details, shall be prepared by a licensed professional engineer using the actual conditions of the proposed site. Final wall design must address both internal and external drainage and all modes of wall stability.

Typical Reinforced Wall Section

Note:

One degree or zero degree batter angle walls are available using blocks with 7 1/2" (190 mm) or 6 3/4" (171 mm) knobs (Specialty items)

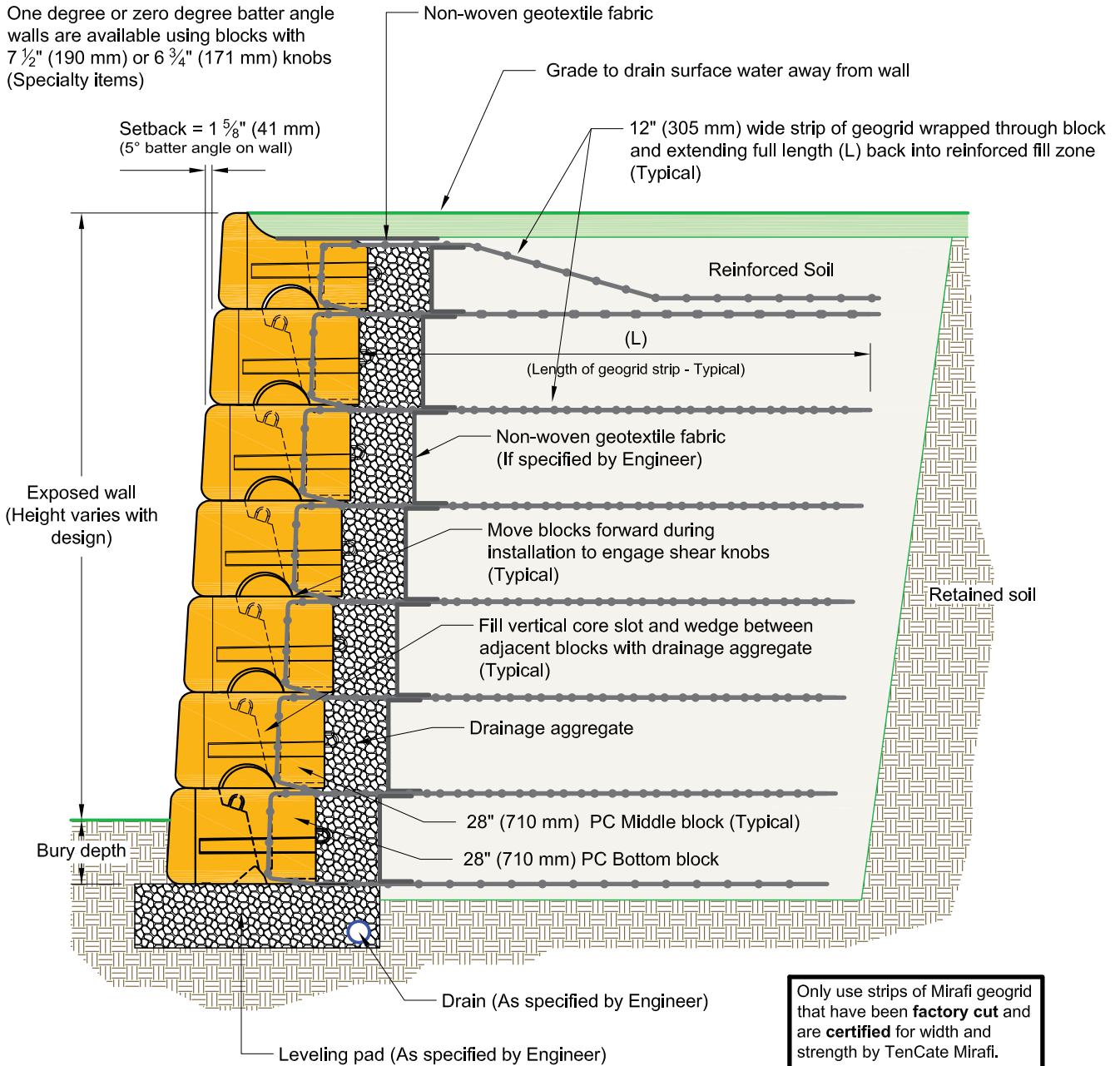

This drawing is for reference only. Determination of the suitability and/or manner of use of any details contained in this document is the sole responsibility of the design engineer of record. Final project designs, including all construction details, shall be prepared by a licensed professional engineer using the actual conditions of the proposed site.

Conceptual Seawall Detail

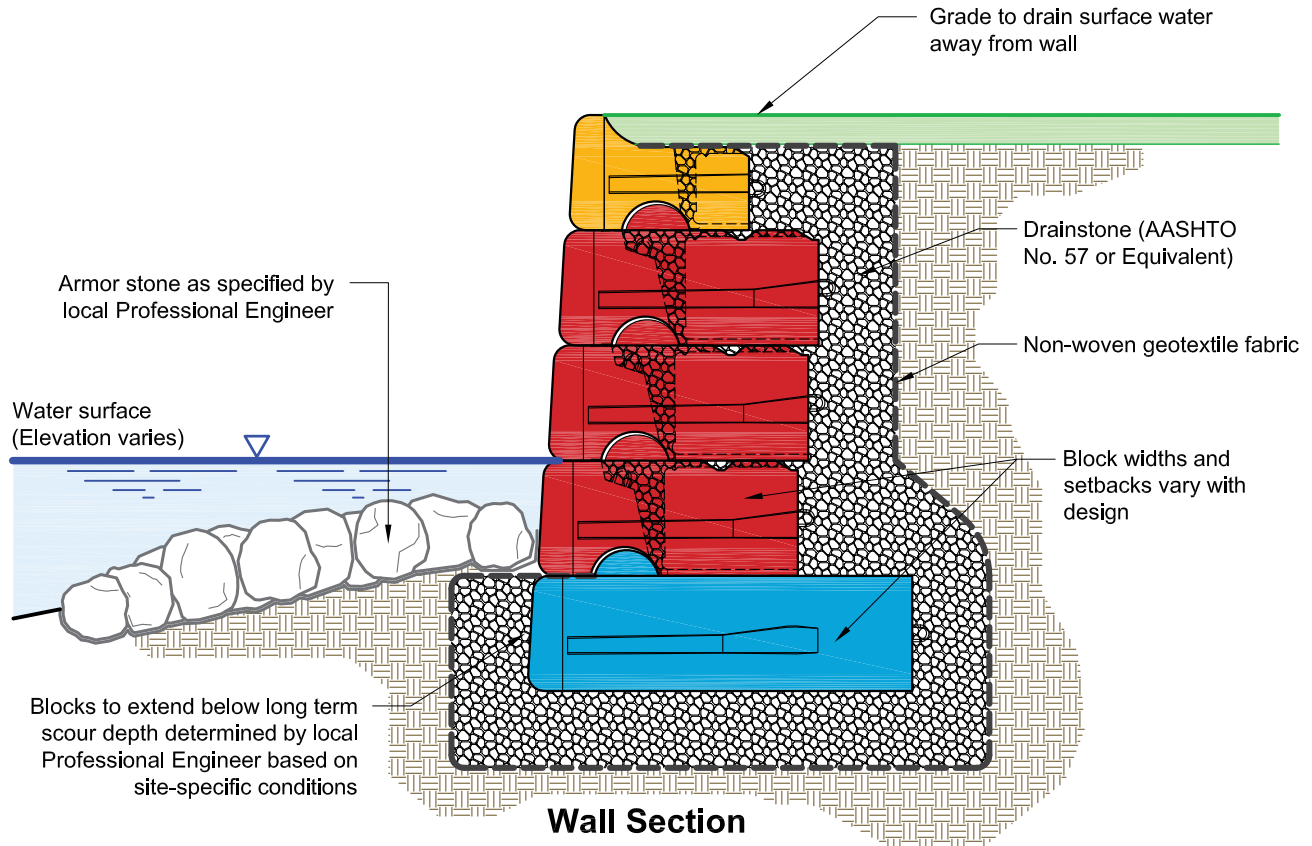

Notes:

- Use ASTM No. 57 stone (or as specified by local Professional Engineer) to infill between blocks.
- Preliminary wall height charts do not apply and should not be used for walls in water applications due to the variety of site-specific variables.
- Contact your local Professional Engineer for specific details and final design.
- Walls may require geogrid reinforcement.
- Refer to final engineering plans.

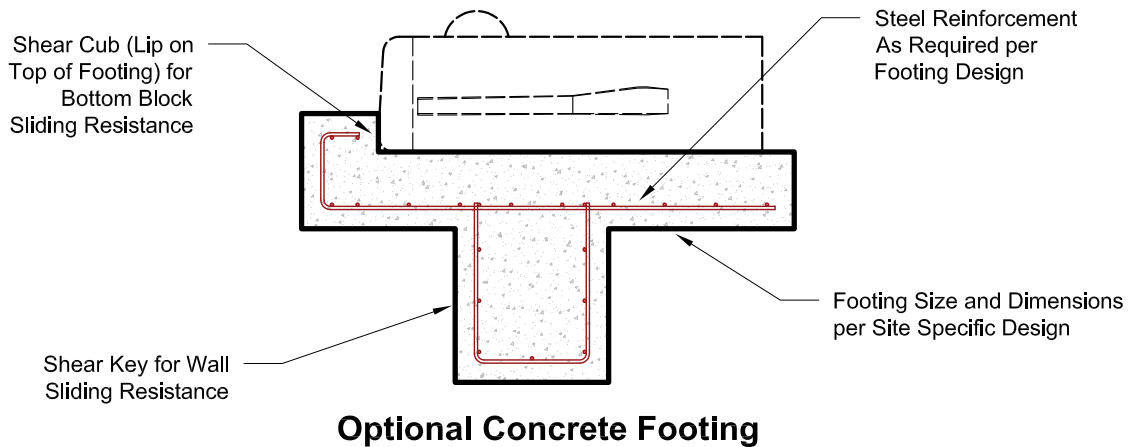

This drawing is for reference only. Determination of the suitability and/or manner of use of any details contained in this document is the sole responsibility of the design engineer of record. Final project designs, including all construction details, shall be prepared by a licensed professional engineer using the actual conditions of the proposed site.

Conceptual Sheetpile Protected Seawall Detail

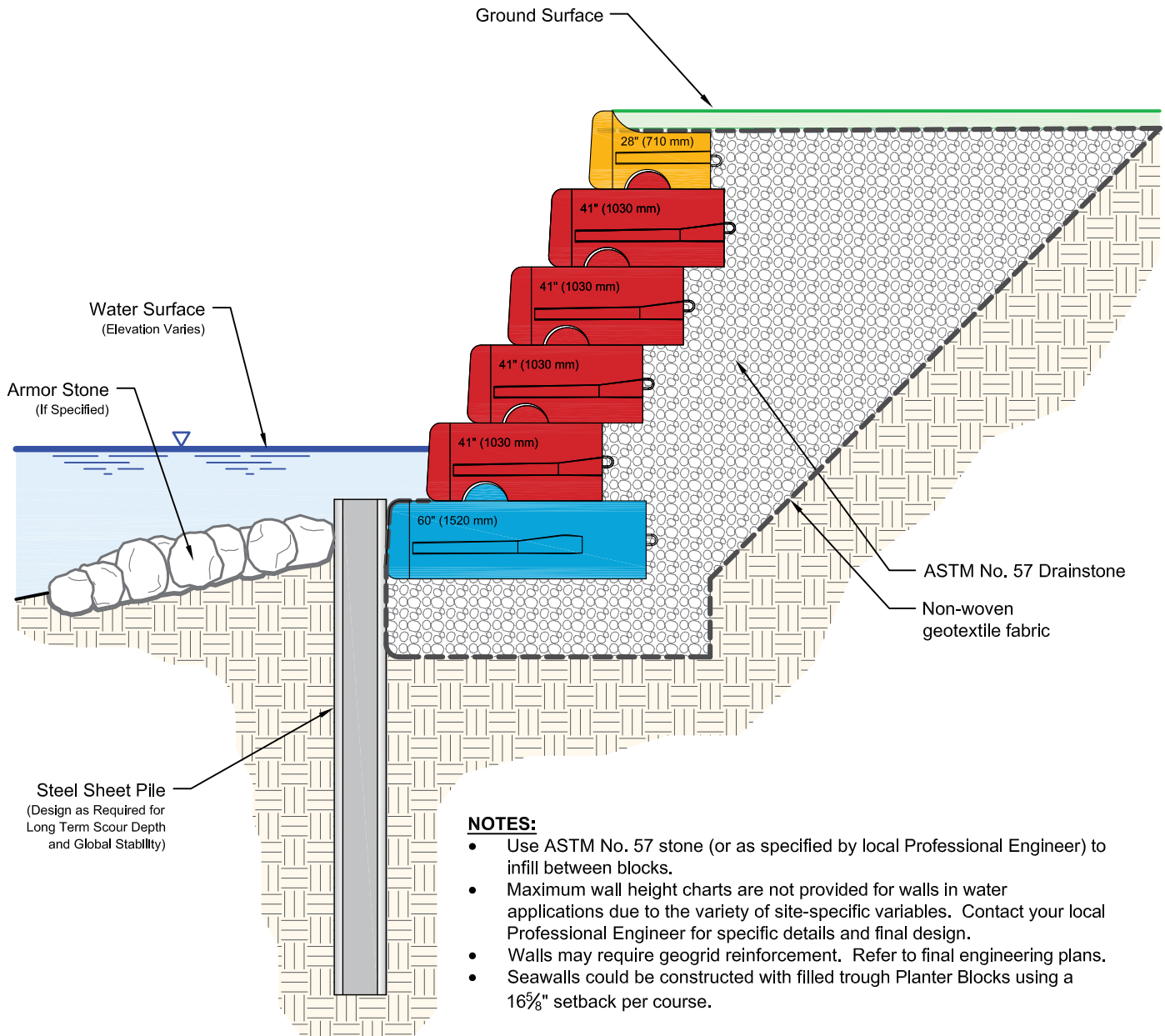

This drawing is for reference only. Determination of the suitability and/or manner of use of any details contained in this document is the sole responsibility of the design engineer of record. Final project designs, including all construction details, shall be prepared by a licensed professional engineer using the actual conditions of the proposed site.

Internal Drainage Options

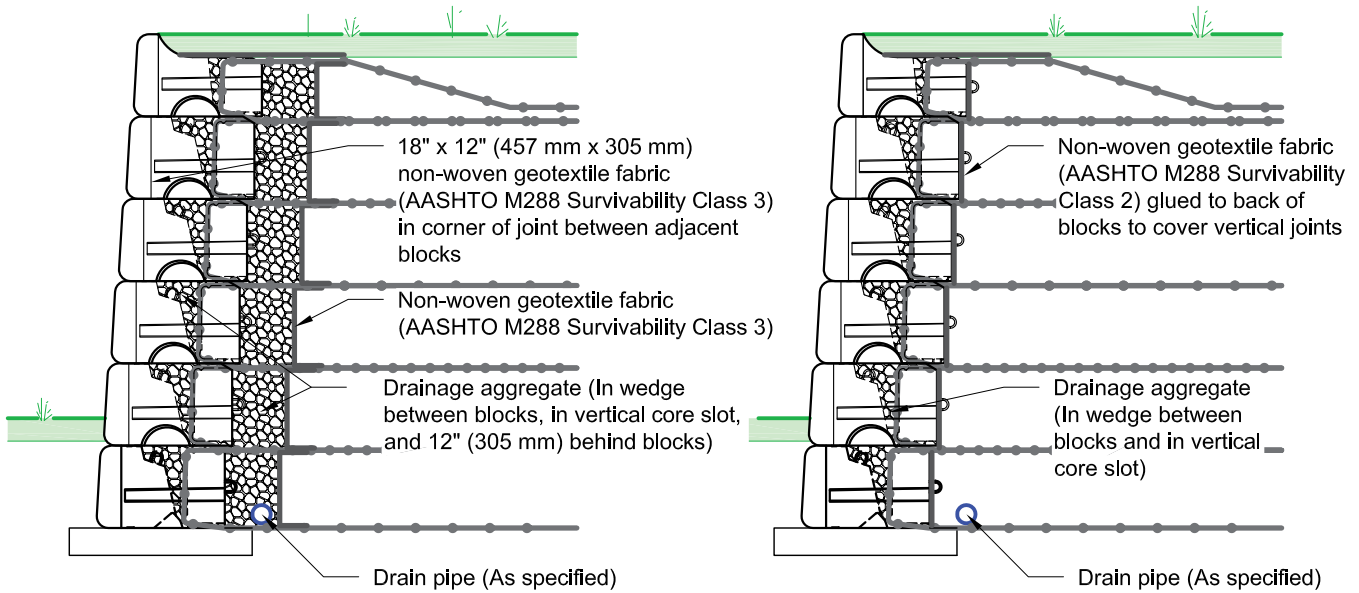

Typical Section - Option 1

Typical Section - Option 2

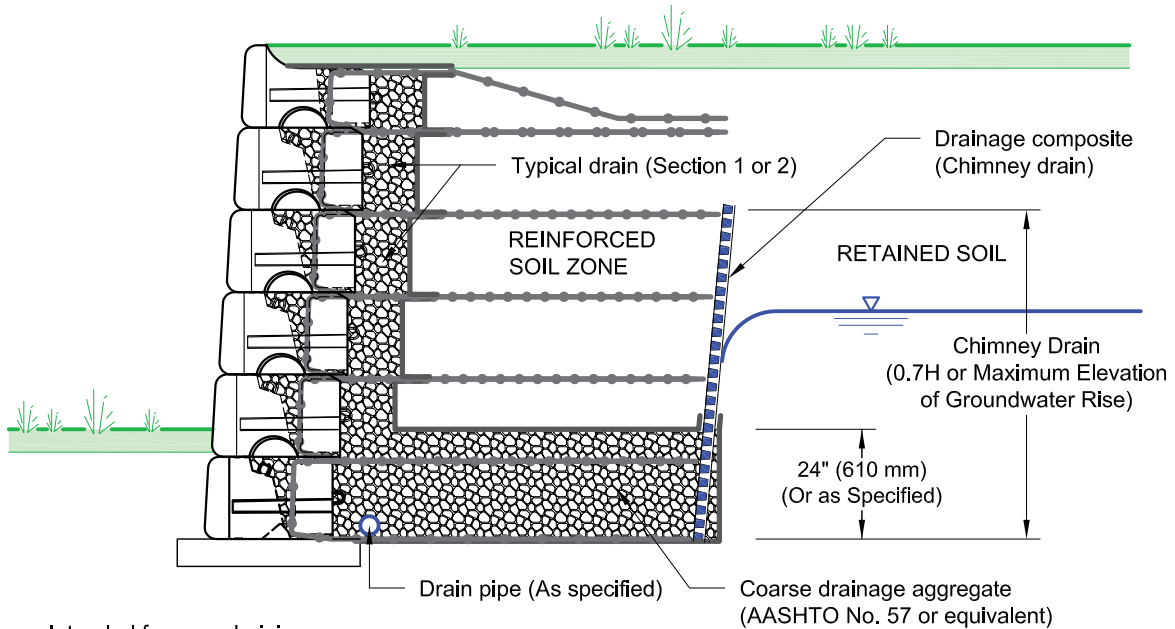

Intended for poor-draining retained soils and/or areas with potential groundwater impact

Blanket and Chimney Drain Section

This drawing is for reference only. Determination of the suitability and/or manner of use of any details contained in this document is the sole responsibility of the design engineer of record. Final project designs, including all construction details, shall be prepared by a licensed professional engineer using the actual conditions of the proposed site.

Typical Drainage Detail - Cross Section

Applicable for sites with groundwater well below the leveling pad elevation and well-drained retained soils.

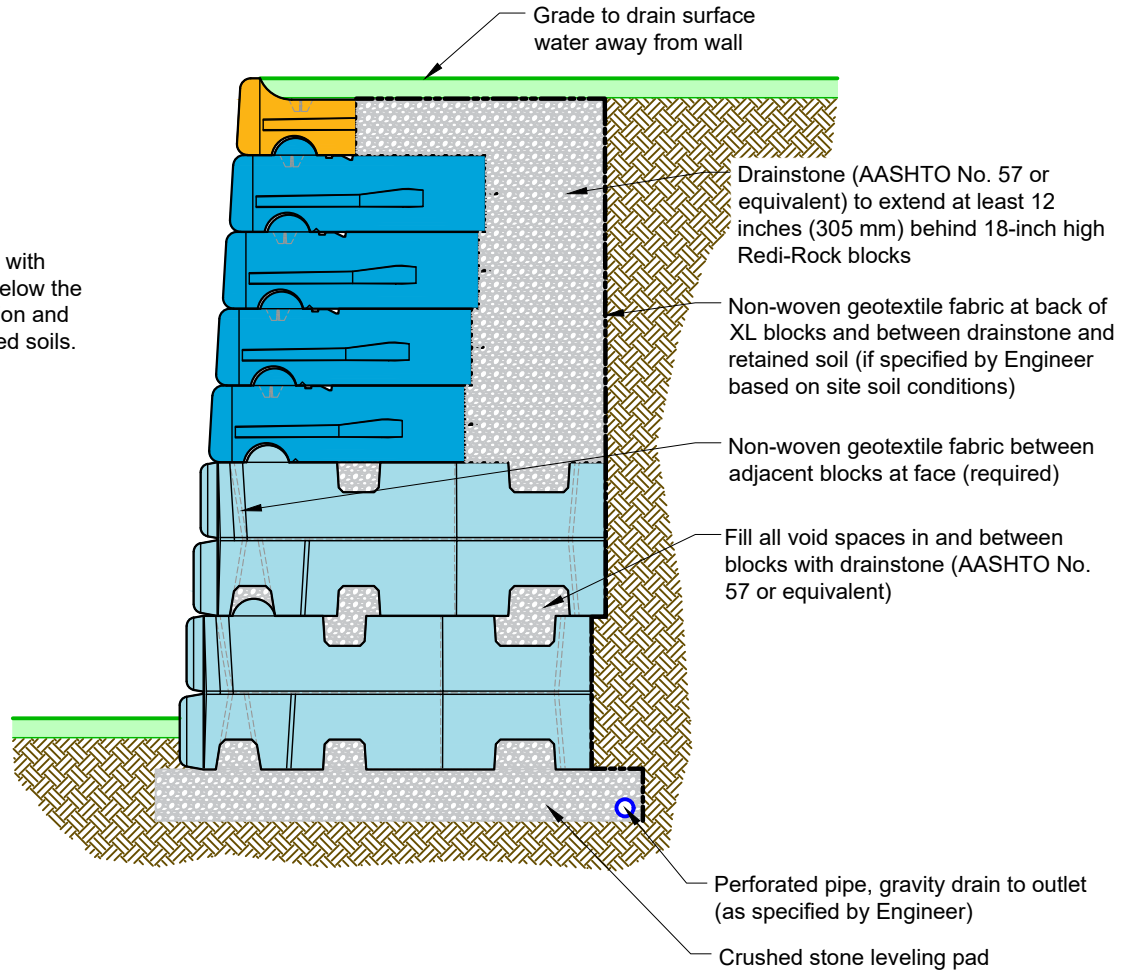

Alternate Detail for Concrete or Impervious Leveling Pad

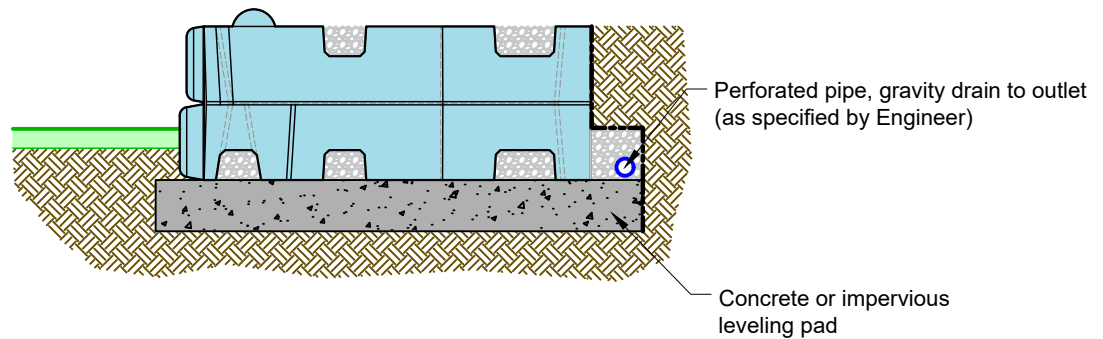

This drawing is for reference only. Determination of the suitability and/or manner of use of any details contained in this document is the sole responsibility of the design engineer of record. Final project designs, including all construction details, shall be prepared by a licensed professional engineer using the actual conditions of the proposed site.

Typical Drainage Detail - Isometric View

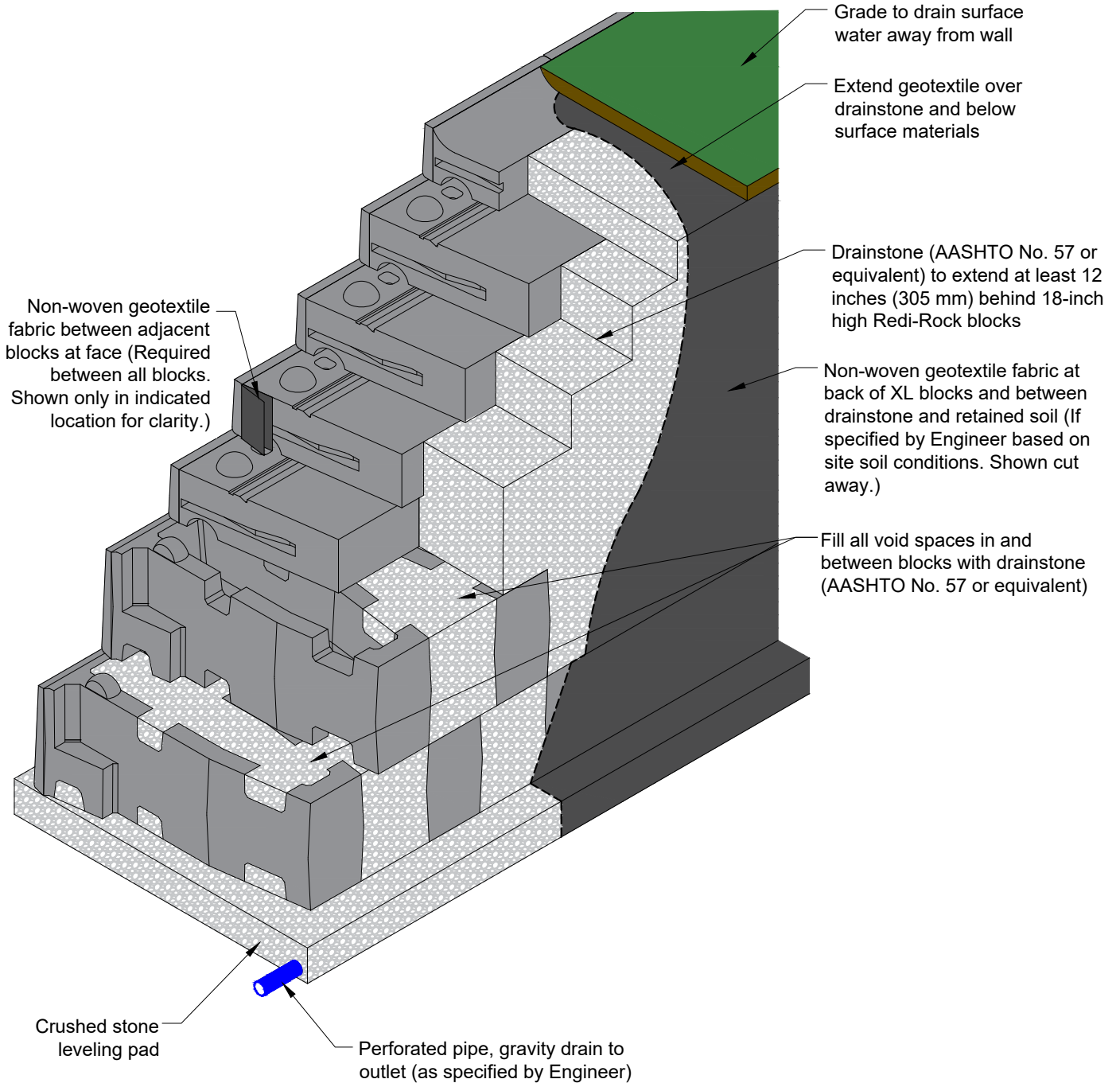

This drawing is for reference only. Determination of the suitability and/or manner of use of any details contained in this document is the sole responsibility of the design engineer of record. Final project designs, including all construction details, shall be prepared by a licensed professional engineer using the actual conditions of the proposed site.

Wall Drain Weep Hole Options

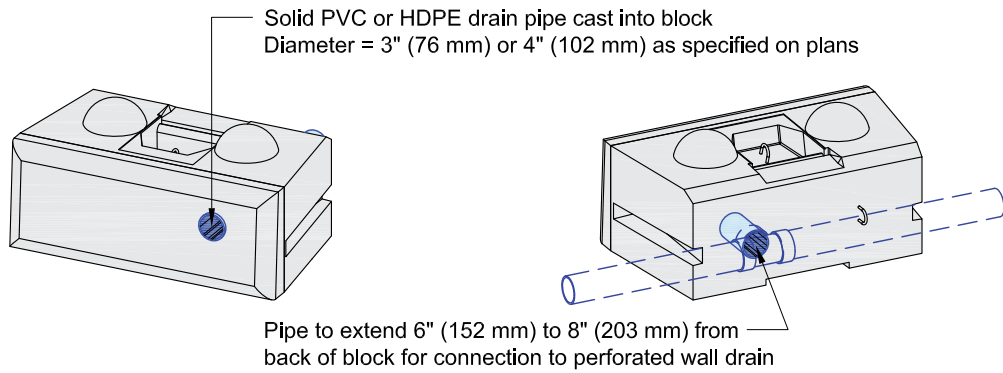

Custom Pipe Cast into Block

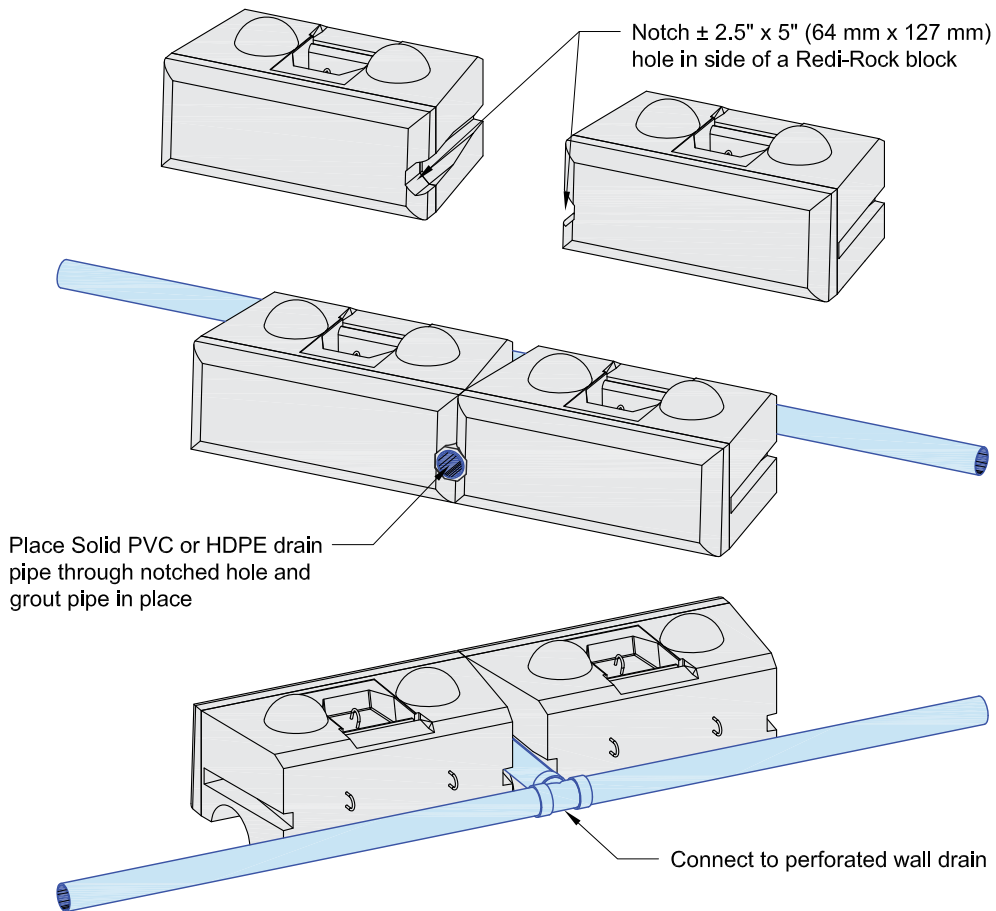

Field Installed Pipe

This drawing is for reference only. Determination of the suitability and/or manner of use of any details contained in this document is the sole responsibility of the design engineer of record. Final project designs, including all construction details, shall be prepared by a licensed professional engineer using the actual conditions of the proposed site.

90° Outside Corner

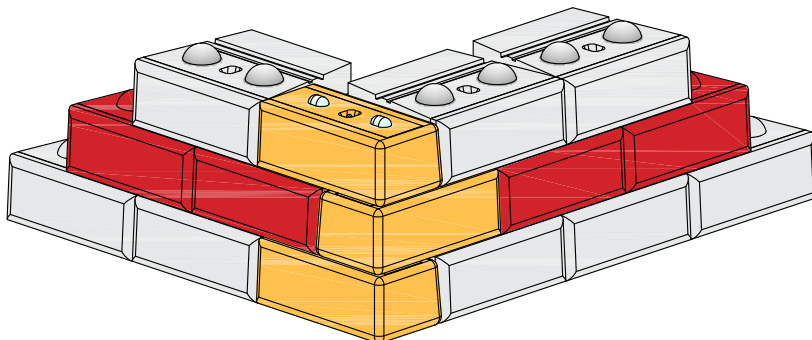

Isometric View of Corner

The top row of blocks in this diagram are shown in red. They have been cutout in line with their bottom grooves to show how they fit with the knobs on the bottom row of blocks.

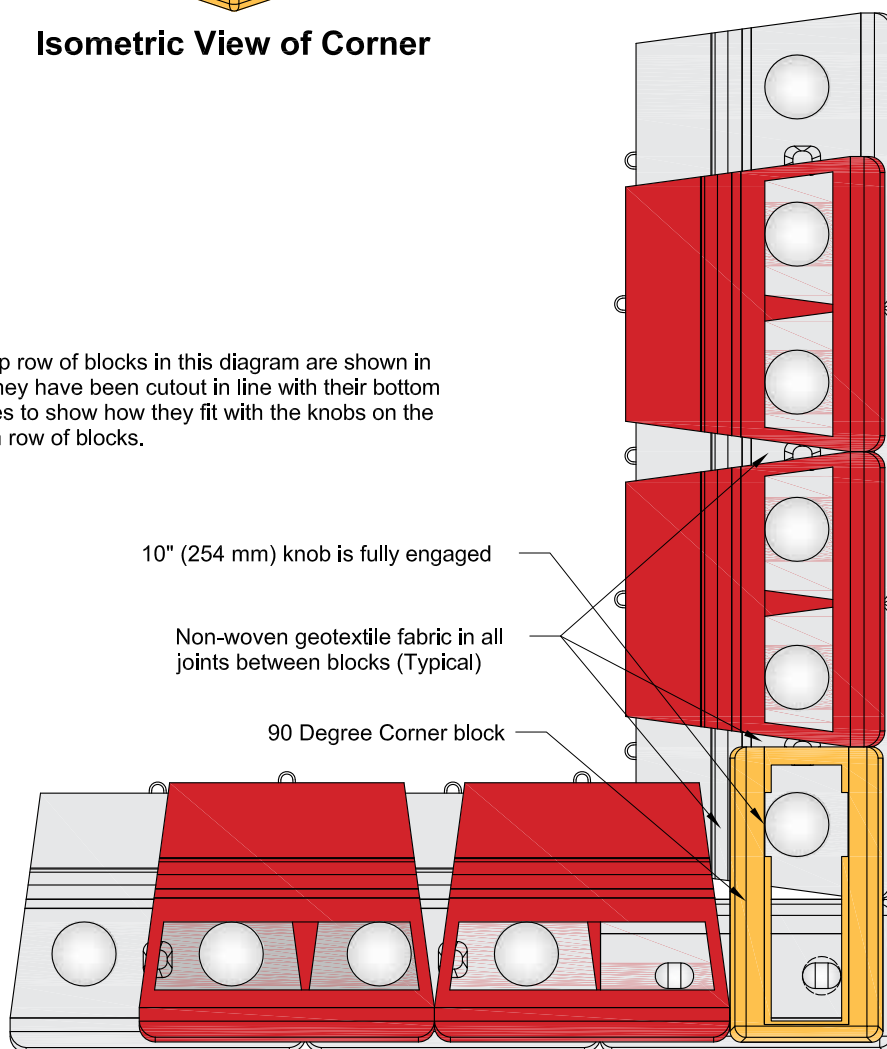

10" (254 mm) knob is fully engaged

Non-woven geotextile fabric in all joints between blocks (Typical)

90 Degree Corner block

Top View of Bottom Two Rows

This drawing is for reference only. Determination of the suitability and/or manner of use of any details contained in this document is the sole responsibility of the design engineer of record. Final project designs, including all construction details, shall be prepared by a licensed professional engineer using the actual conditions of the proposed site.

Steps Through Wall

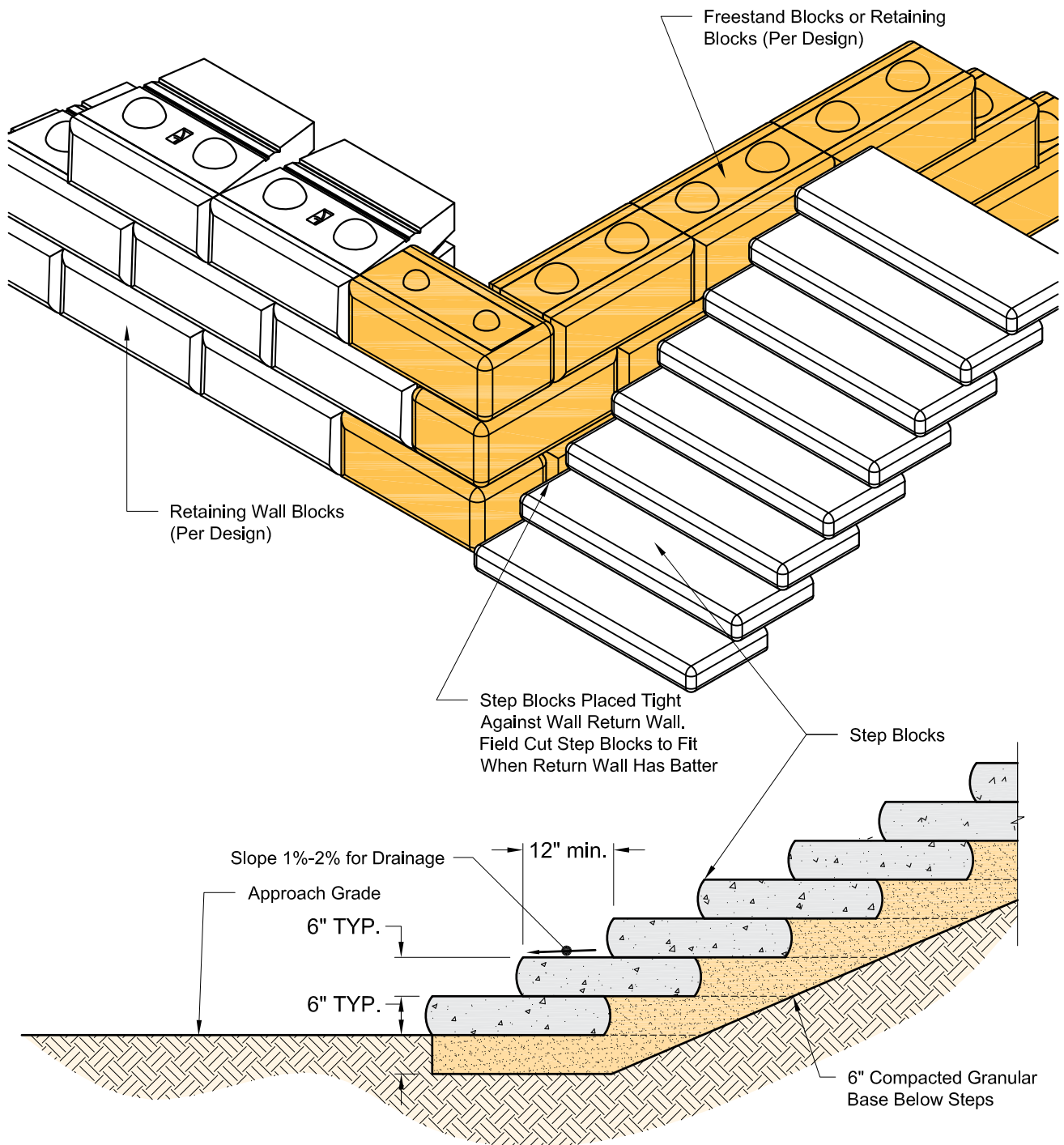

Stair Section

This drawing is for reference only. Determination of the suitability and/or manner of use of any details contained in this document is the sole responsibility of the design engineer of record. Final project designs, including all construction details, shall be prepared by a licensed professional engineer using the actual conditions of the proposed site.

Flush End to 90° Corner

Notes:

- Wall is flush with building.
- Rows 2, 4, 6, and 8 require approximately 1/8" (3 mm) gaps between blocks for length of wall given.
- Solution shown based on a 24" (610 mm) wide corner block.

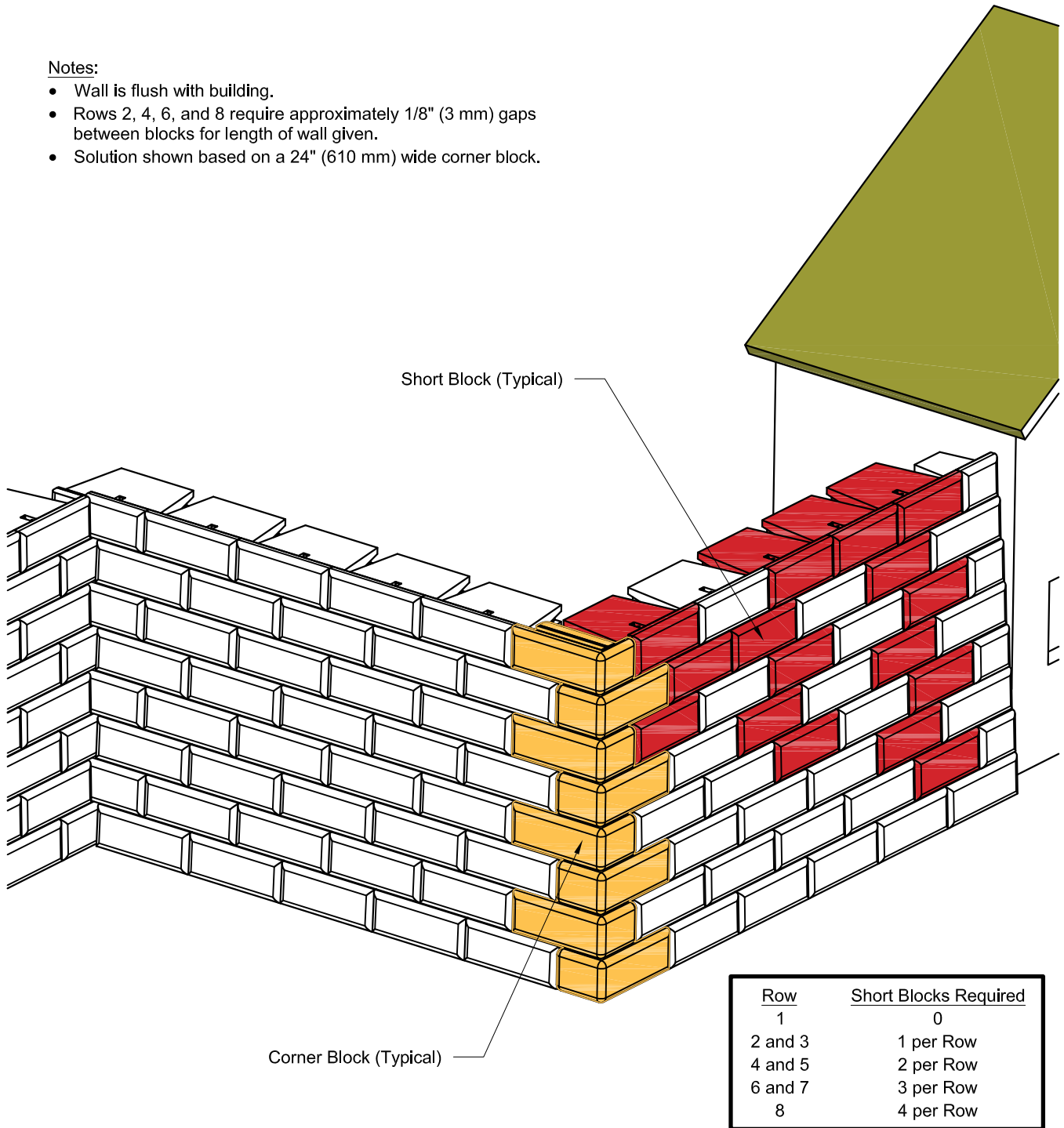

This drawing is for reference only. Determination of the suitability and/or manner of use of any details contained in this document is the sole responsibility of the design engineer of record. Final project designs, including all construction details, shall be prepared by a licensed professional engineer using the actual conditions of the proposed site.

Double 90° Outside Corner - Short Block Solution

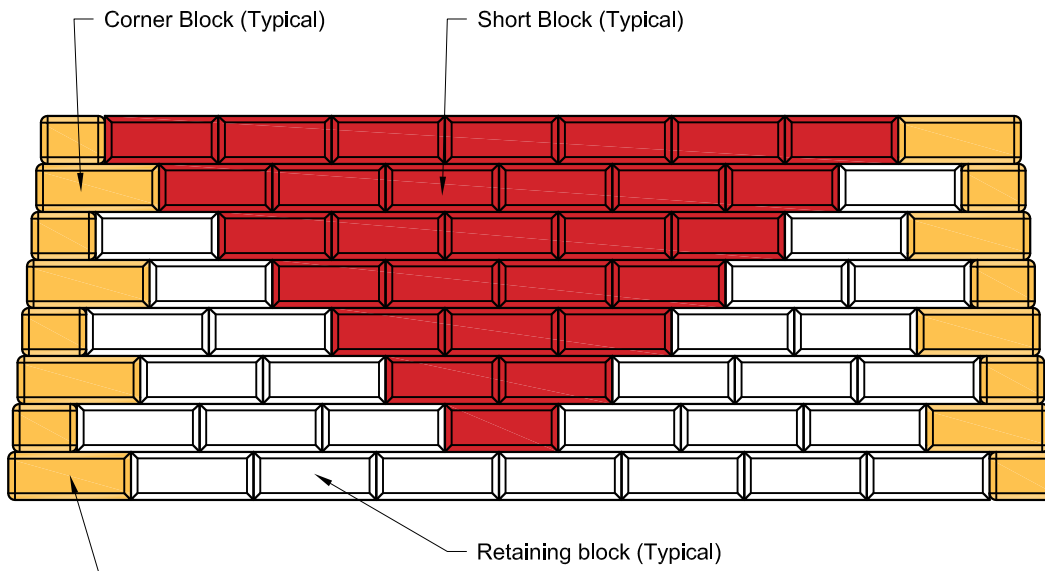

Alternate long and short face of Freestanding Corner block on either end of row for proper spacing (Typical)

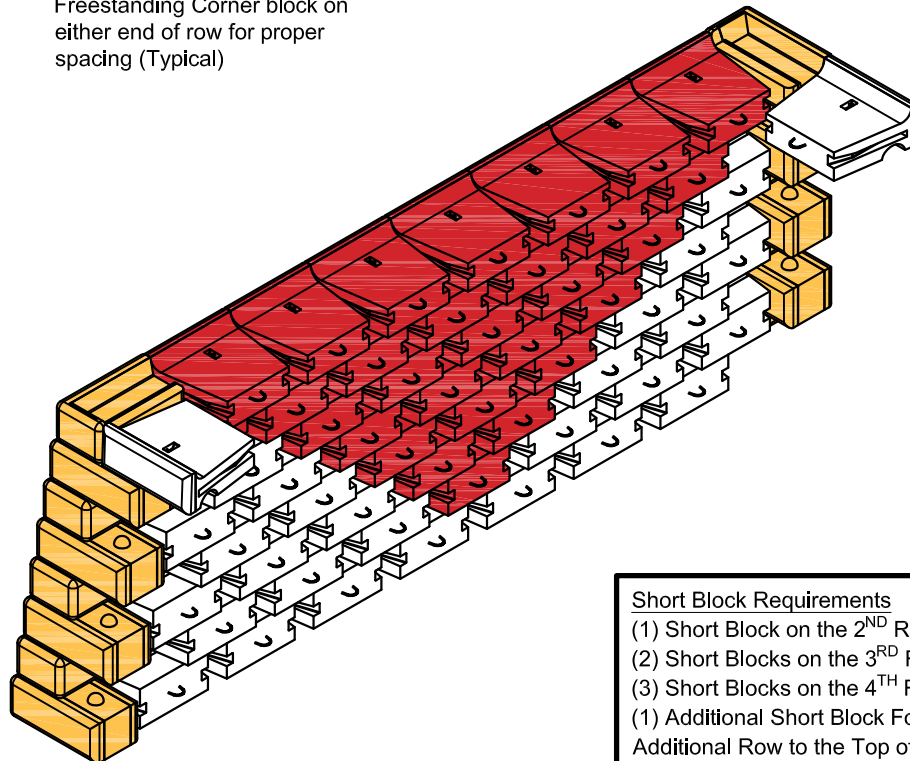

- Short Block Requirements**

 - (1) Short Block on the 2ND Row
 - (2) Short Blocks on the 3RD Row
 - (3) Short Blocks on the 4TH Row
 - (1) Additional Short Block For Every Additional Row to the Top of the Wall

This drawing is for reference only. Determination of the suitability and/or manner of use of any details contained in this document is the sole responsibility of the design engineer of record. Final project designs, including all construction details, shall be prepared by a licensed professional engineer using the actual conditions of the proposed site.

Transitions Into Planters

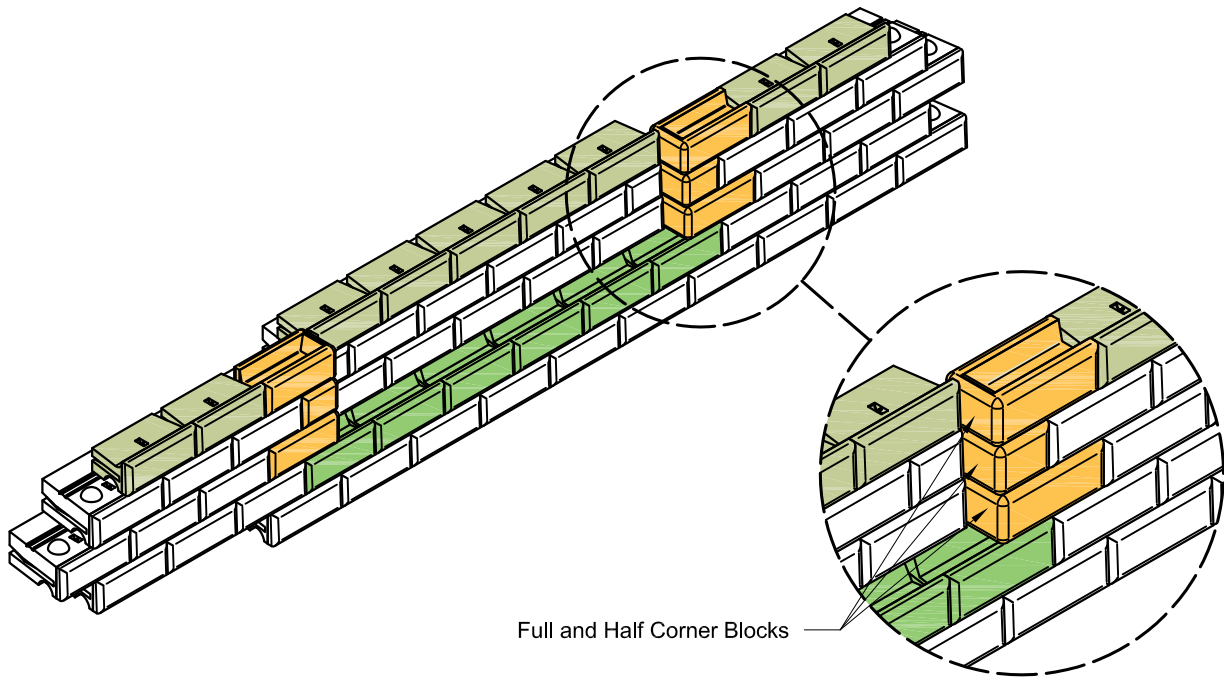
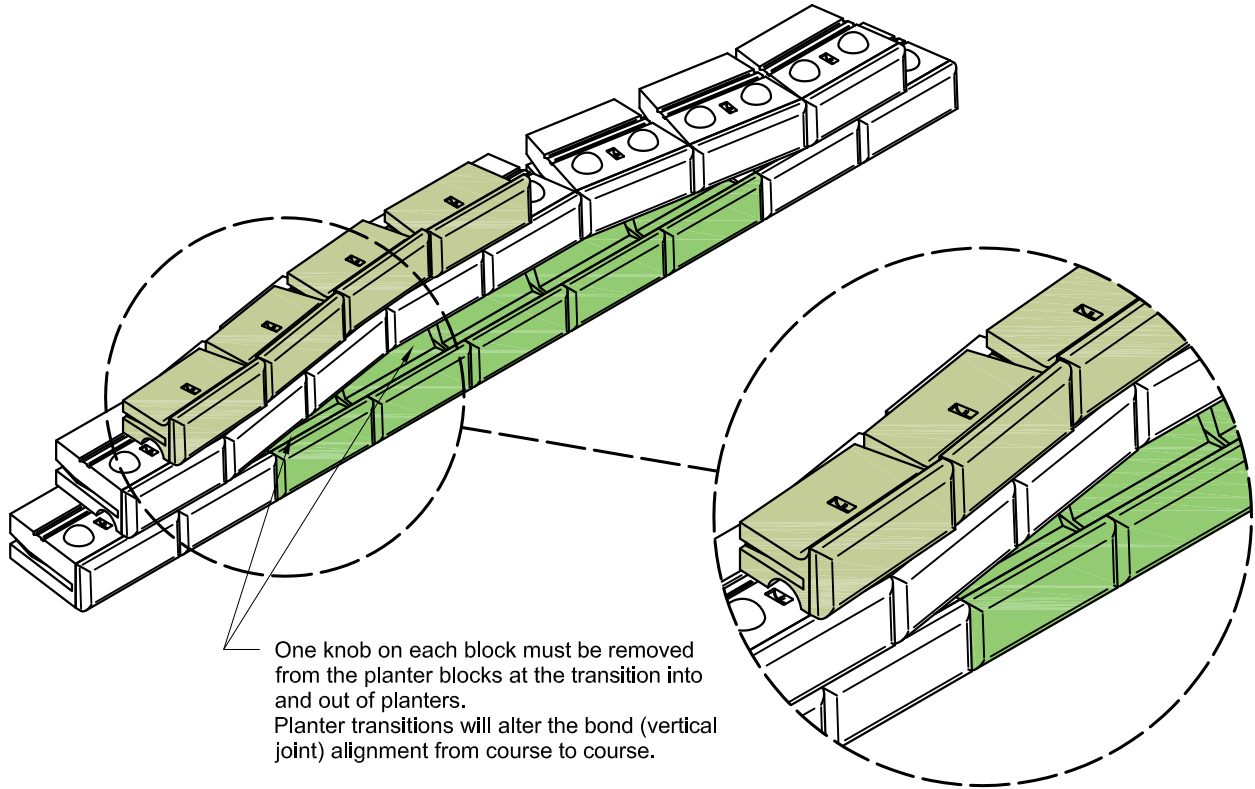

This drawing is for reference only. Determination of the suitability and/or manner of use of any details contained in this document is the sole responsibility of the design engineer of record. Final project designs, including all construction details, shall be prepared by a licensed professional engineer using the actual conditions of the proposed site.

Transition From 5° Batter to 9" (230 mm) Setback

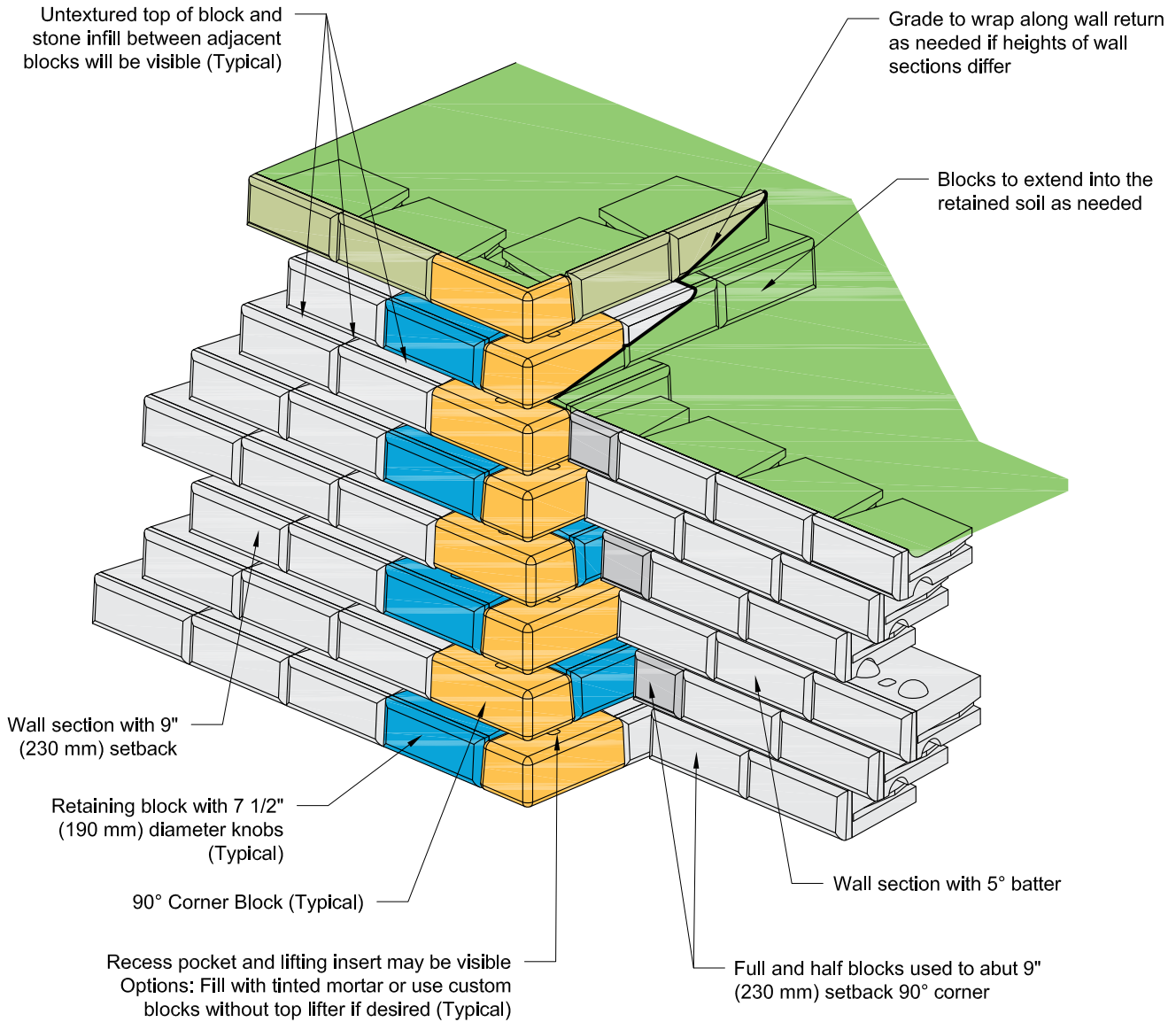

Preferred option is to start construction at transition and work away in both directions.
If construction cannot start at transition, blocks must be field cut as needed to fit.

This drawing is for reference only. Determination of the suitability and/or manner of use of any details contained in this document is the sole responsibility of the design engineer of record. Final project designs, including all construction details, shall be prepared by a licensed professional engineer using the actual conditions of the proposed site.

90° Outside Corner for 9" (230 mm) Setback Walls

Recess pocket and lifting insert may be visible
Options: Fill with tinted mortar or use custom blocks without top lifter if desired (Typical)

Freestanding Corner Top Block (Typical)

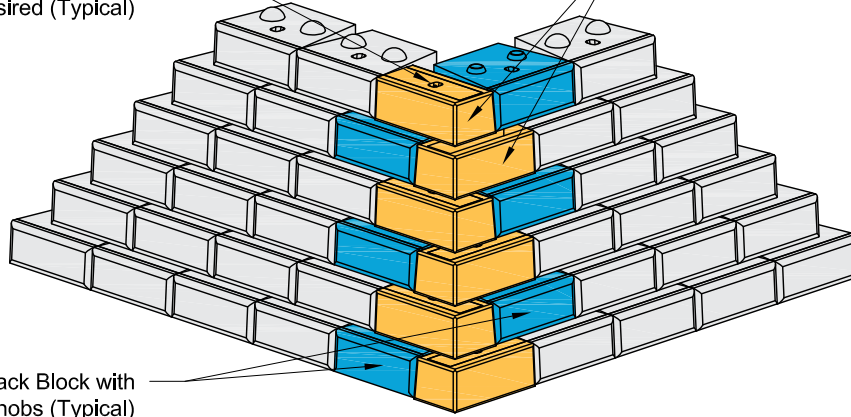

Special 9" (230 mm) Setback Block with 7 1/2" (190 mm) diameter knobs (Typical)

Multiple Row Installation

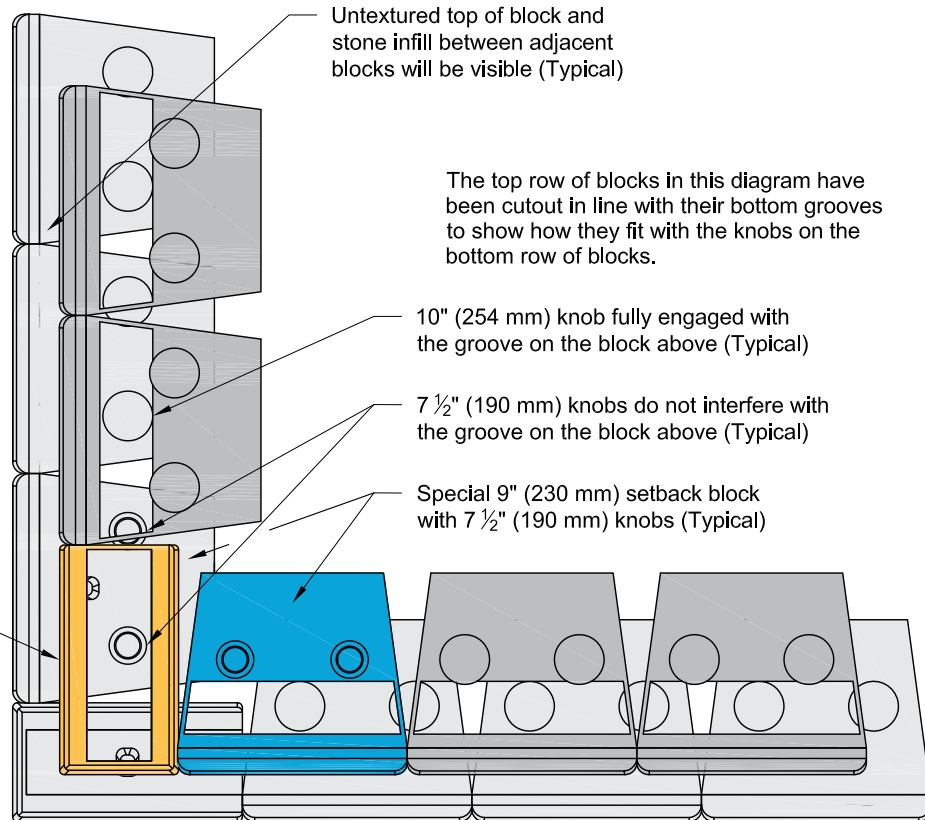

Untextured top of block and stone infill between adjacent blocks will be visible (Typical)

The top row of blocks in this diagram have been cutout in line with their bottom grooves to show how they fit with the knobs on the bottom row of blocks.

10" (254 mm) knob fully engaged with the groove on the block above (Typical)

7 1/2" (190 mm) knobs do not interfere with the groove on the block above (Typical)

Special 9" (230 mm) setback block with 7 1/2" (190 mm) knobs (Typical)

Freestanding Corner Top block (Typical)

Top View of Bottom Two Rows

This drawing is for reference only. Determination of the suitability and/or manner of use of any details contained in this document is the sole responsibility of the design engineer of record. Final project designs, including all construction details, shall be prepared by a licensed professional engineer using the actual conditions of the proposed site.

Double 90° Outside Corner for 9" (230 mm) Setback Walls

Short Block Requirements
 (1) 9" (230 mm) Setback Short block on the 2nd row
 (2) 9" (230 mm) Setback Short block on the 3rd row
 (3) 9" (230 mm) Setback Short block on the 4th row
 (1) Additional 9" (230 mm) Setback Short block for every additional row to the top of the wall

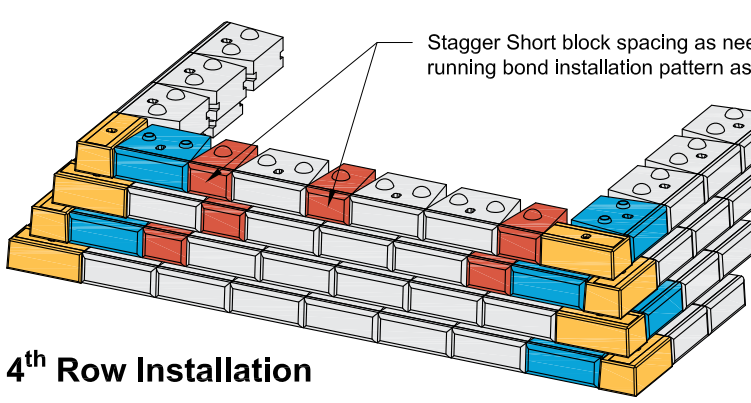
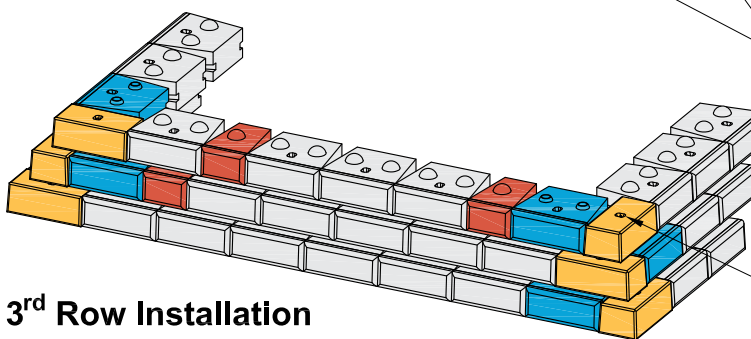
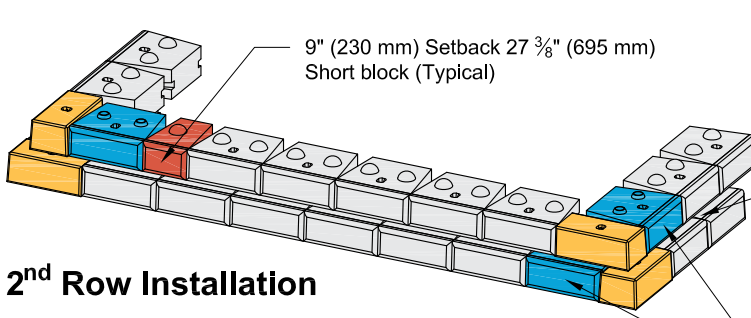
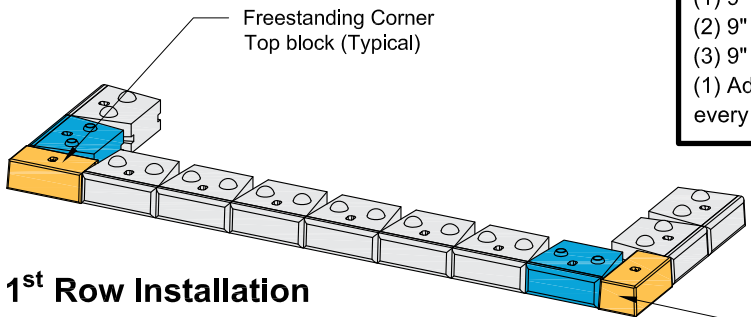

This drawing is for reference only. Determination of the suitability and/or manner of use of any details contained in this document is the sole responsibility of the design engineer of record. Final project designs, including all construction details, shall be prepared by a licensed professional engineer using the actual conditions of the proposed site.

Stepped 9" (230 mm) Setback Wall with Aligned Base

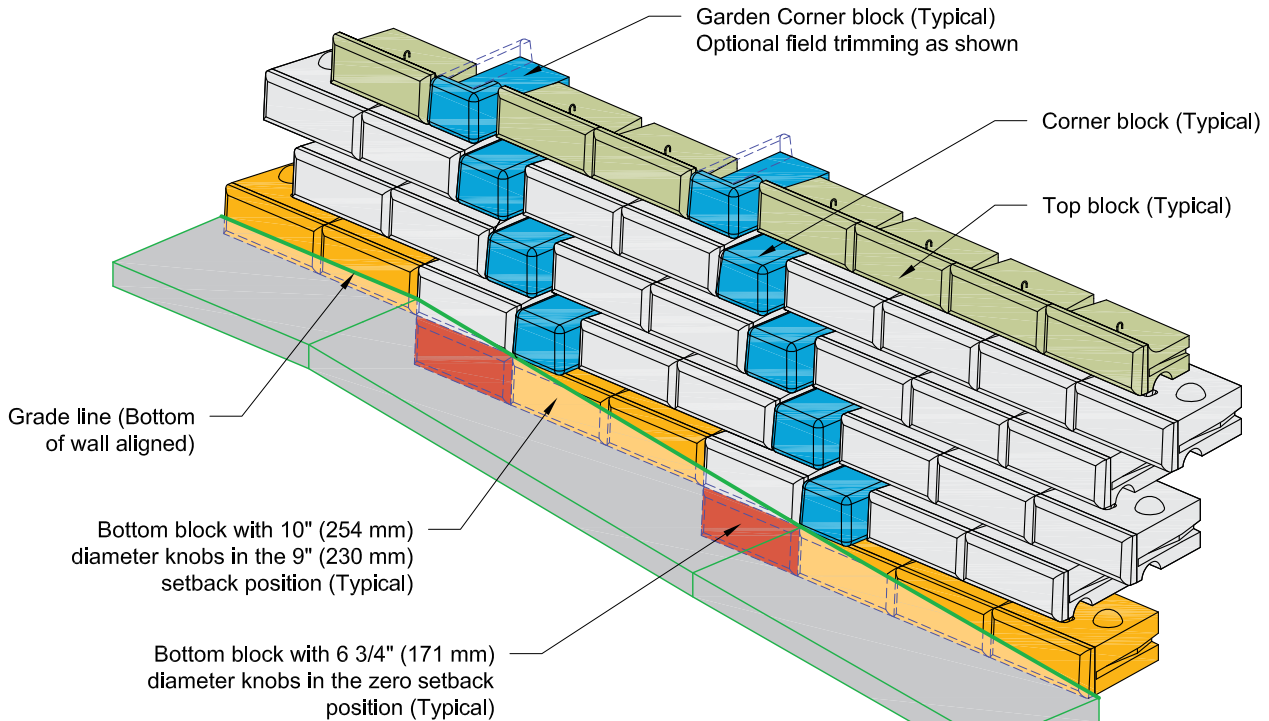

Parallel Setback

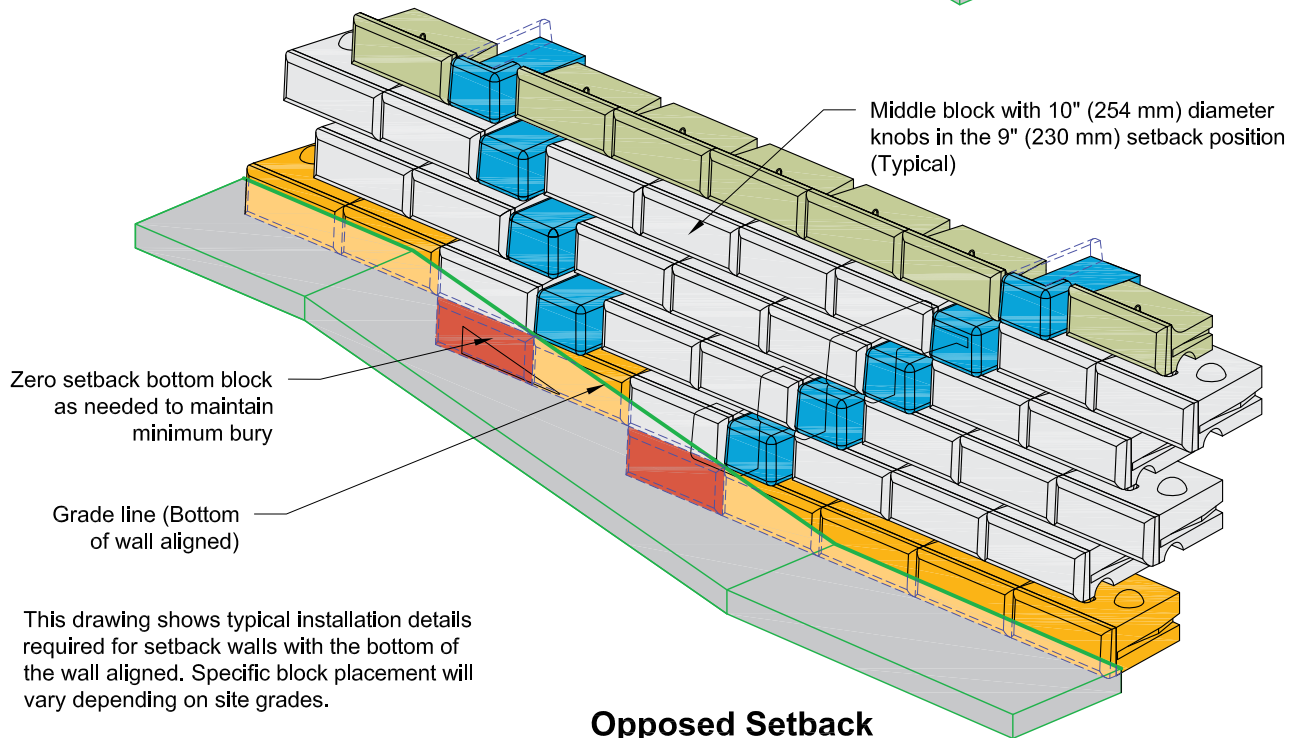

Opposed Setback

This drawing is for reference only. Determination of the suitability and/or manner of use of any details contained in this document is the sole responsibility of the design engineer of record. Final project designs, including all construction details, shall be prepared by a licensed professional engineer using the actual conditions of the proposed site.

Stepped 9" (230 mm) Setback Wall with Aligned Top

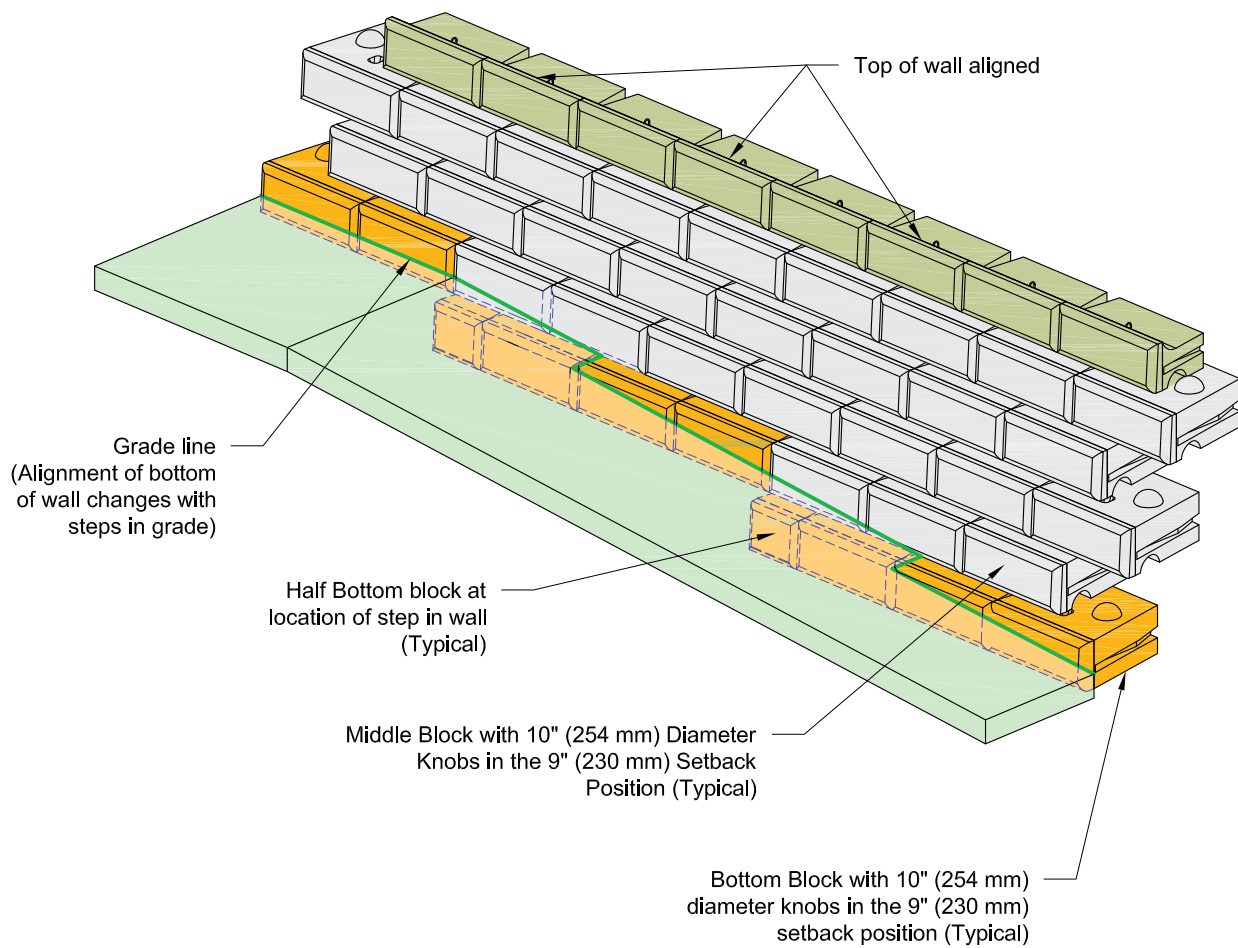

This drawing is for reference only. Determination of the suitability and/or manner of use of any details contained in this document is the sole responsibility of the design engineer of record. Final project designs, including all construction details, shall be prepared by a licensed professional engineer using the actual conditions of the proposed site.

Freestanding and Cap Block Coping

Secure cap block to freestanding block with polyurethane sealant.
 Optional shear lugs cast into cap block or rebar ties that can be embedded in site-cast concrete (with garden block) are also available.

Setback = 0" (0 mm) on Freestanding blocks

Setback = $2 \frac{7}{8}$ " (73 mm) when 10" (254 mm) knob used
 Setback = $1 \frac{5}{8}$ " (41 mm) when $7 \frac{1}{2}$ " (190 mm) knob used

Setback = $1 \frac{5}{8}$ " (41 mm) when 10" (254 mm) knob used

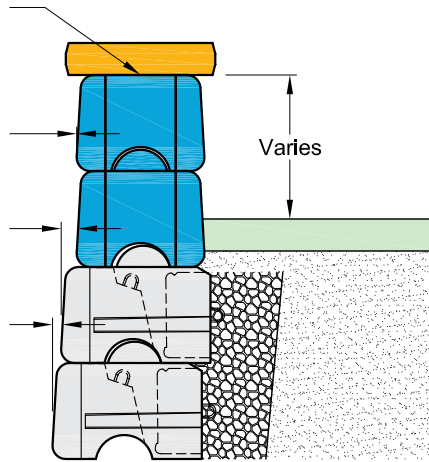

Section View

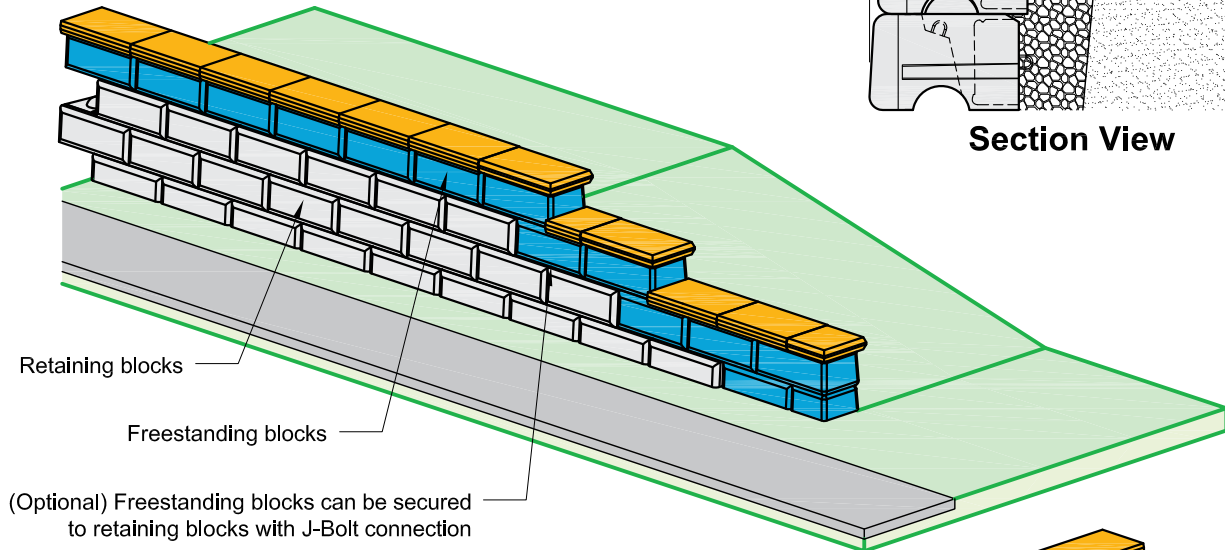

Front View

(Optional) Freestanding blocks can be secured to retaining blocks with J-Bolt connection

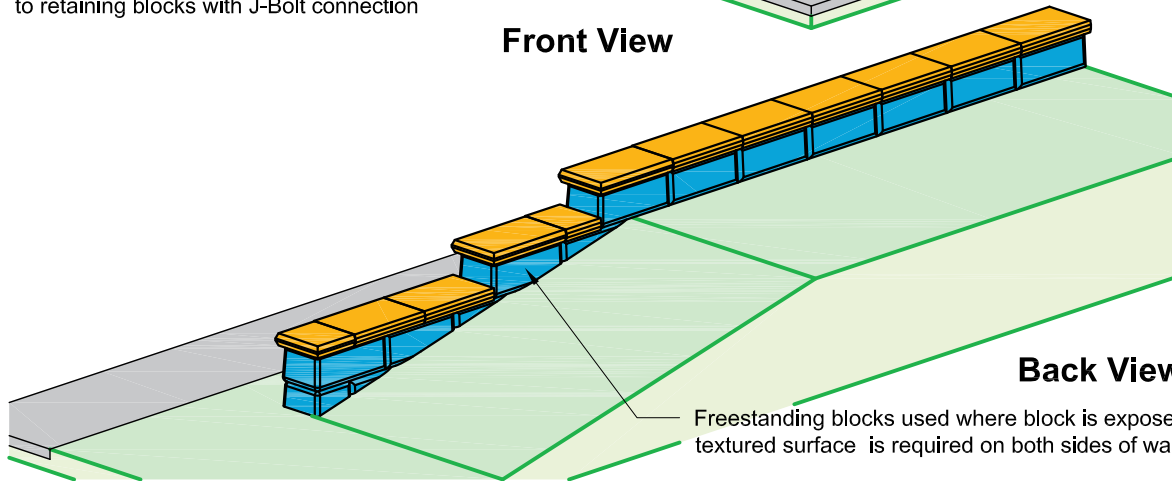

Back View

Freestanding blocks used where block is exposed and textured surface is required on both sides of wall

One-component, highly flexible, non-priming, gun grade, high performance elastomeric polyurethane sealant shall have movement of plus or minus 25% per ASTM C719, tensile strength greater than 200 psi (1.4 MPa) per ASTM D412, and adhesion to peel on concrete greater than 20 PLI per ASTM C794. Apply sealant in one and one half-inch (1.5") (38 mm) diameter round "hersey kiss" shaped dollops located in two rows at the top of the Freestanding blocks at 8" (203 mm) on center.

This drawing is for reference only. Determination of the suitability and/or manner of use of any details contained in this document is the sole responsibility of the design engineer of record. Final project designs, including all construction details, shall be prepared by a licensed professional engineer using the actual conditions of the proposed site.

Drainage Swale Options

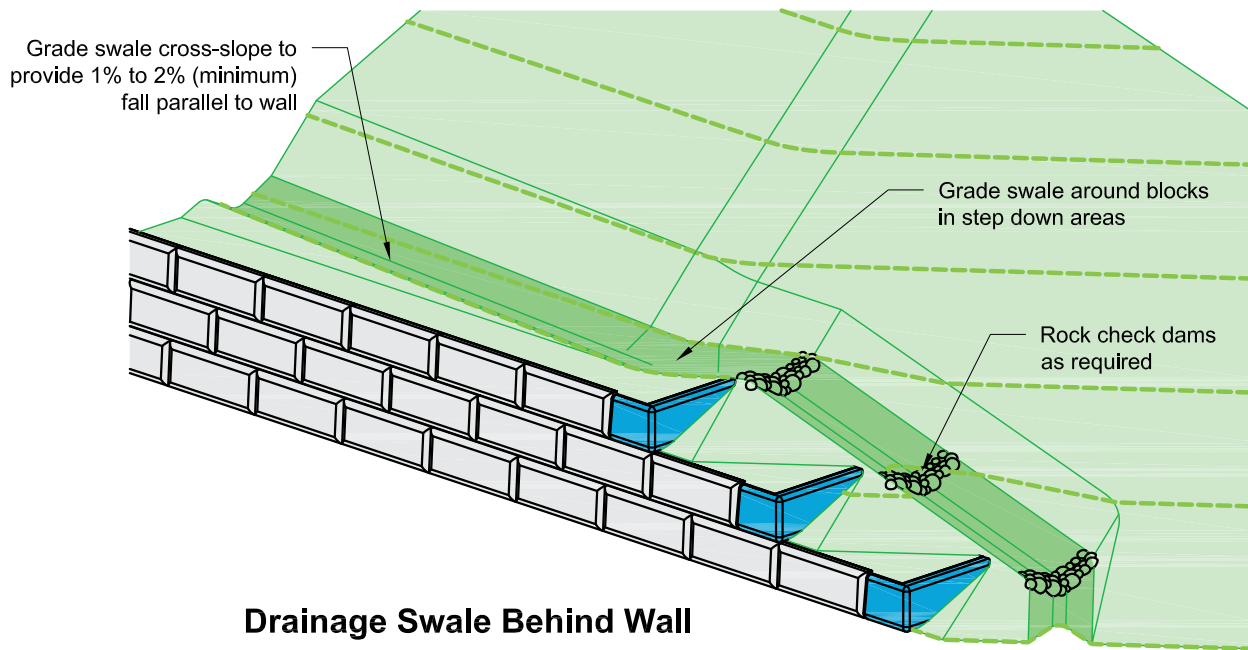
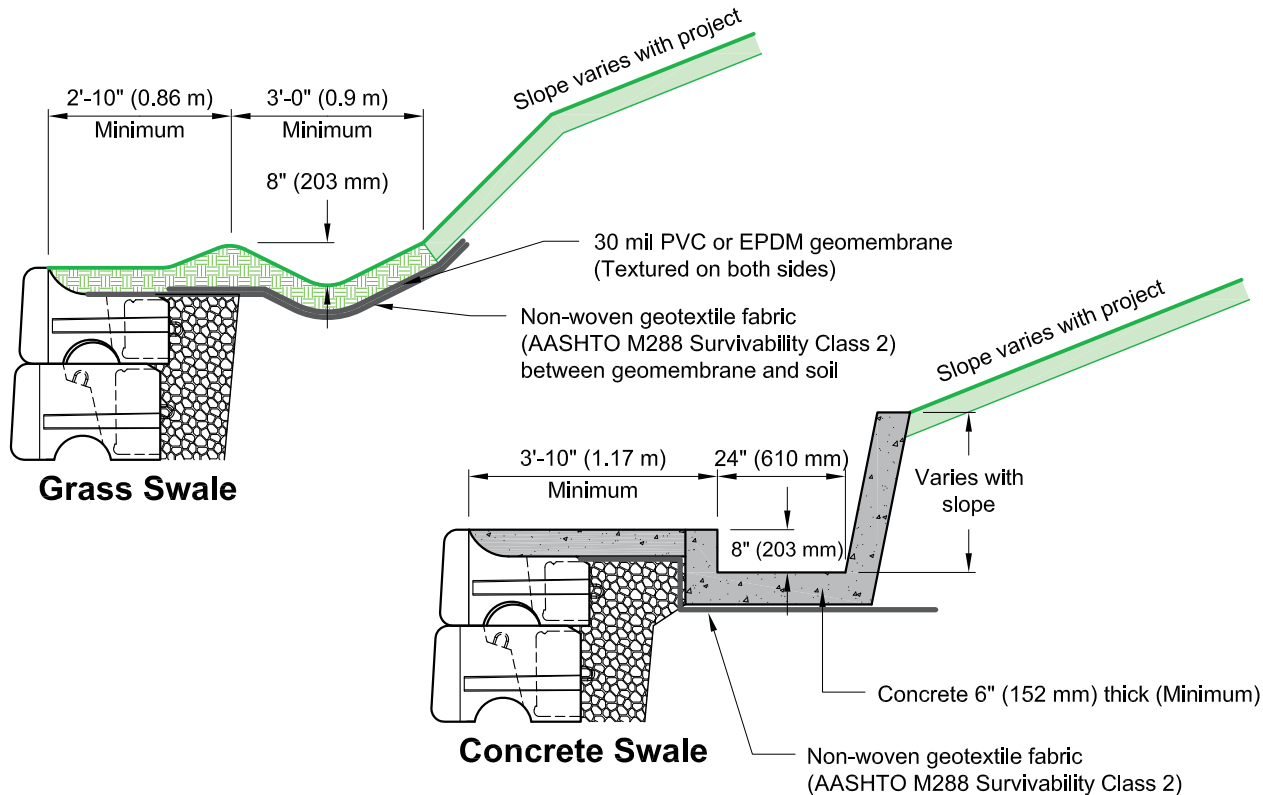

Drainage Swale Behind Wall

This drawing is for reference only. Determination of the suitability and/or manner of use of any details contained in this document is the sole responsibility of the design engineer of record. Final project designs, including all construction details, shall be prepared by a licensed professional engineer using the actual conditions of the proposed site.

Top Block Coping Option

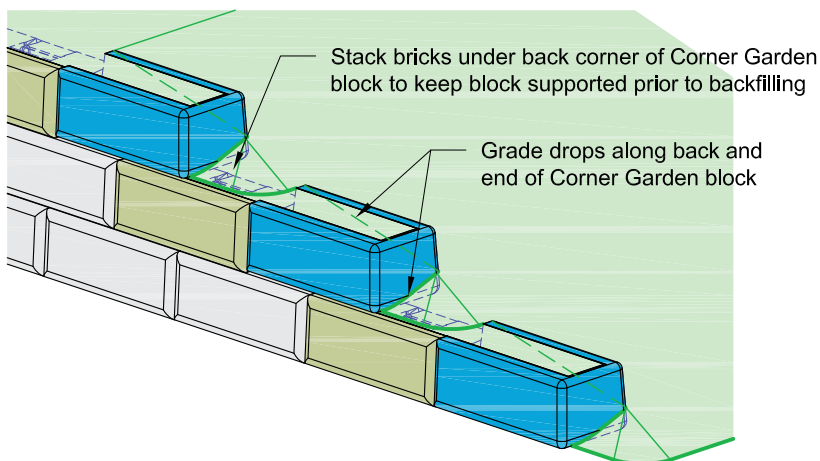

Alternate Garden Block Placement

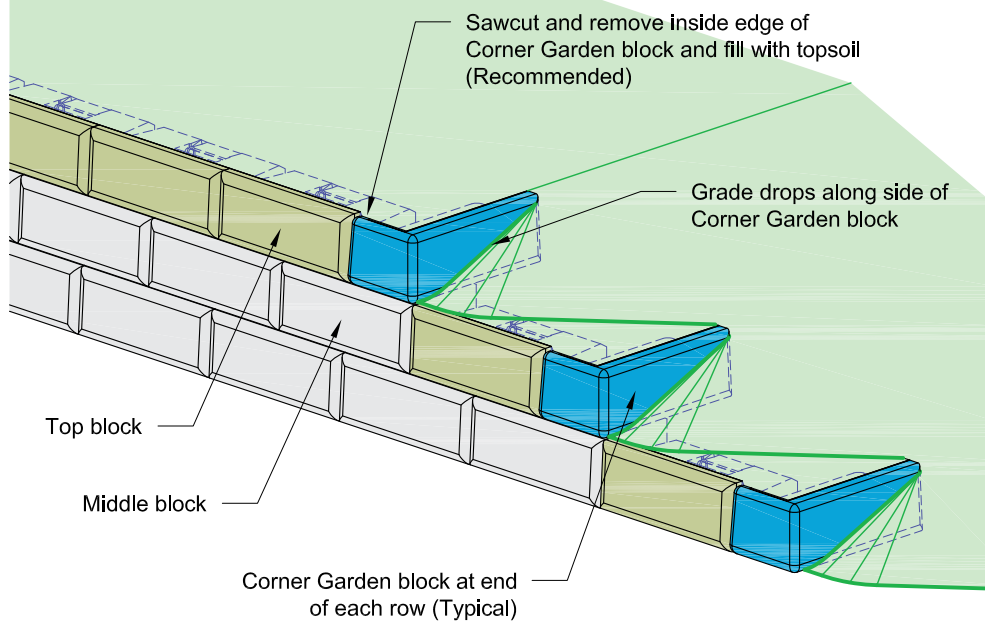

Note: Corner Garden Blocks are shown, Half Corner Garden Blocks are optional as grading permits.

This drawing is for reference only. Determination of the suitability and/or manner of use of any details contained in this document is the sole responsibility of the design engineer of record. Final project designs, including all construction details, shall be prepared by a licensed professional engineer using the actual conditions of the proposed site.

Grade Change on Top of Wall Using 9" (230 mm) Stepdown Blocks

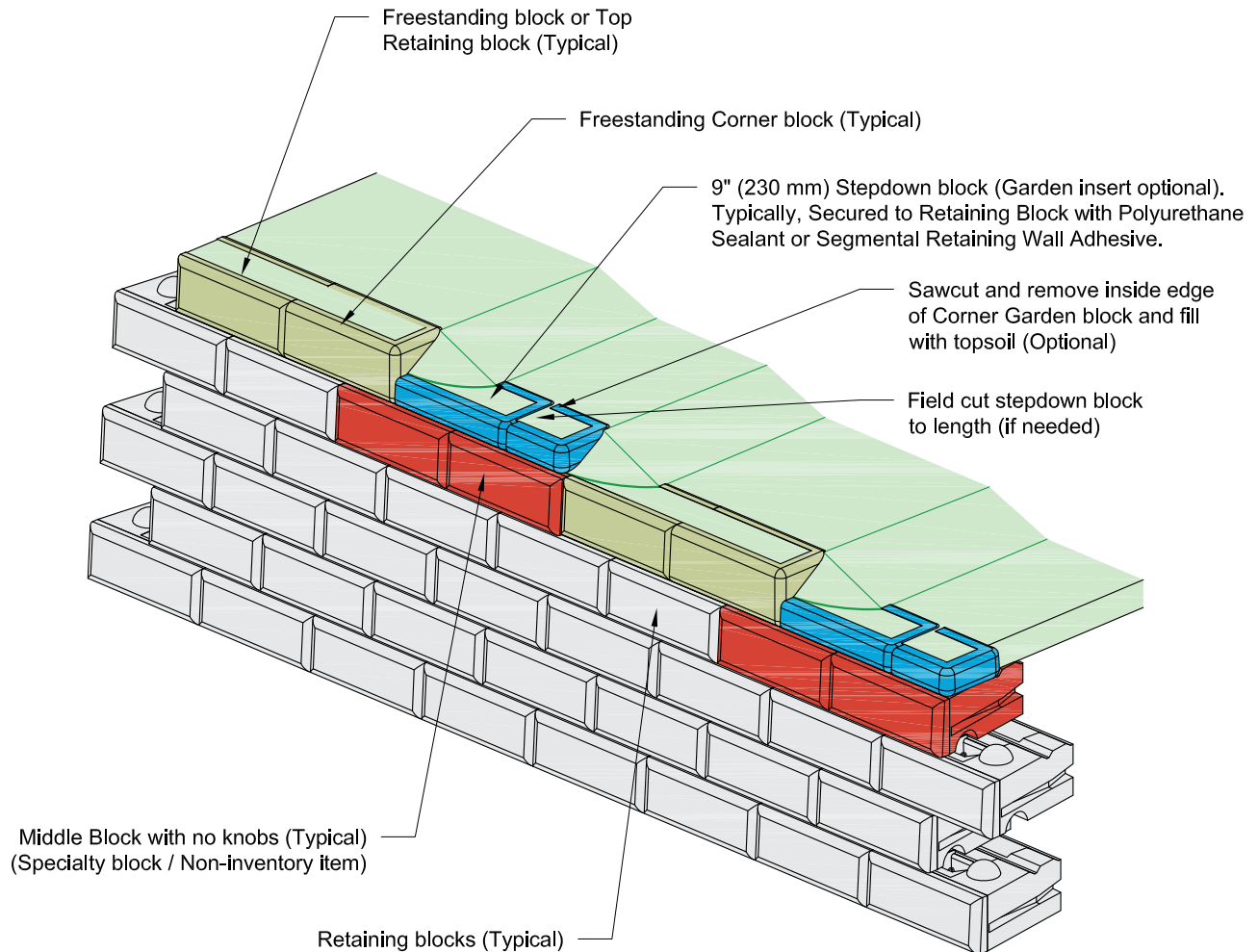

Sealant Adhesive: One-component, highly flexible, non-priming, gun grade, high performance elastomeric polyurethane sealant shall have movement of plus or minus 25% per ASTM C719, tensile strength greater than 200 psi (1.4 MPa) per ASTM D412, and adhesion to peel on concrete greater than 20 PLI per ASTM C794. Apply sealant in one and one half-inch (1.5") (38 mm) diameter round "hersey kiss" shaped dollops located in two rows at 8" (203 mm) on center, immediately below the 9" (230mm) Stepdown Block.

This drawing is for reference only. Determination of the suitability and/or manner of use of any details contained in this document is the sole responsibility of the design engineer of record. Final project designs, including all construction details, shall be prepared by a licensed professional engineer using the actual conditions of the proposed site.

Geogrid Layout for Convex Curves and Radial Corners

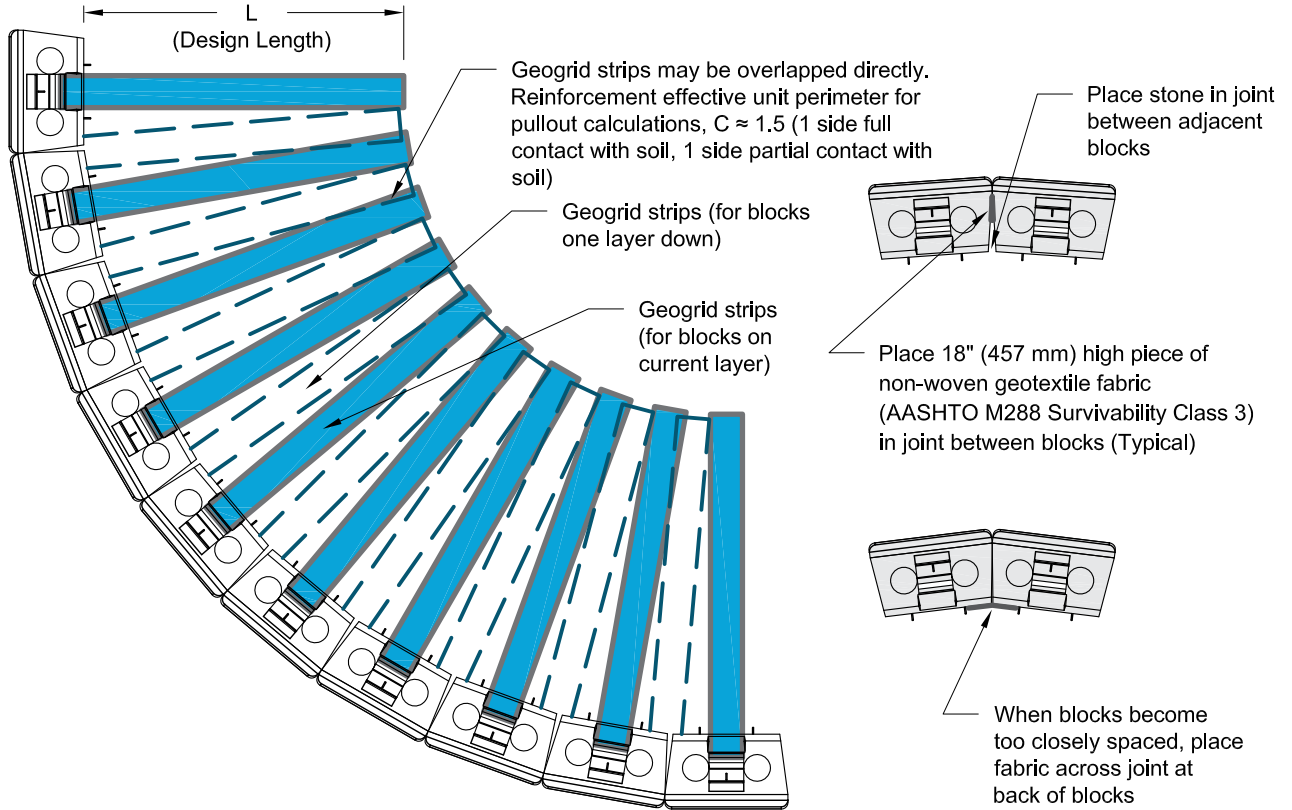

Minimum radius for bottom row

Number of courses	Height of wall	Radius from face of block	Distance between blocks*
1	1'-6" (0.46 m)	14'-6" (4.42 m)	0.13" (3 mm)
2	3'-0" (0.91 m)	14'-8" (4.47 m)	0.21" (5 mm)
3	4'-6" (1.37 m)	14'-10" (4.52 m)	0.28" (7 mm)
4	6'-0" (1.83 m)	15'-0" (4.57 m)	0.36" (9 mm)
5	7'-6" (2.29 m)	15'-2" (4.62 m)	0.43" (11 mm)
6	9'-0" (2.74 m)	15'-4" (4.67 m)	0.50" (13 mm)
7	10'-6" (3.20 m)	15'-6" (4.72 m)	0.57" (15 mm)
8	12'-0" (3.66 m)	15'-8" (4.78 m)	0.63" (16 mm)
9	13'-6" (4.11 m)	15'-10" (4.83 m)	0.70" (18 mm)
10	15'-0" (4.57 m)	16'-0" (4.88 m)	0.76" (19 mm)
11	16'-6" (5.03 m)	16'-2" (4.93 m)	0.83" (21 mm)
12	18'-0" (5.49 m)	16'-4" (4.98 m)	0.88" (22 mm)
13	19'-6" (5.94 m)	16'-6" (5.03 m)	0.95" (24 mm)
14	21'-0" (6.40 m)	16'-8" (5.08 m)	1.01" (26 mm)

14'-6" (4.42 m) is the minimum radius for Redi-Rock blocks. It occurs when all the blocks are placed tight together. A larger radius is required on the bottom row of a Redi-Rock wall to account for the batter between courses of blocks and still provide enough space to construct the top row of blocks.

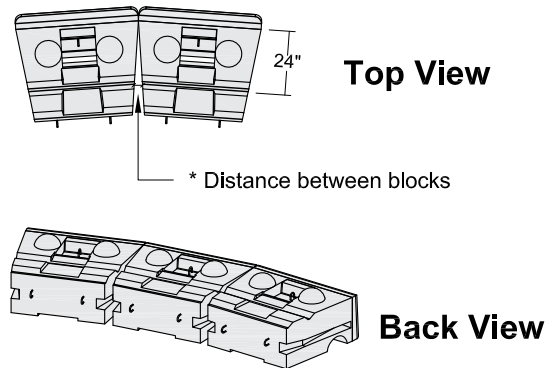

* Distance between blocks is measured at the back of 28" (710 mm) blocks and 24" (610 mm) behind the form parting line (back edge of face texture) for 41" (1030 mm) blocks. This distance is intended to be a guide only. Minimum radius is controlling.

This drawing is for reference only. Determination of the suitability and/or manner of use of any details contained in this document is the sole responsibility of the design engineer of record. Final project designs, including all construction details, shall be prepared by a licensed professional engineer using the actual conditions of the proposed site.

Geogrid Layout for Concave Curves and Radial Corners

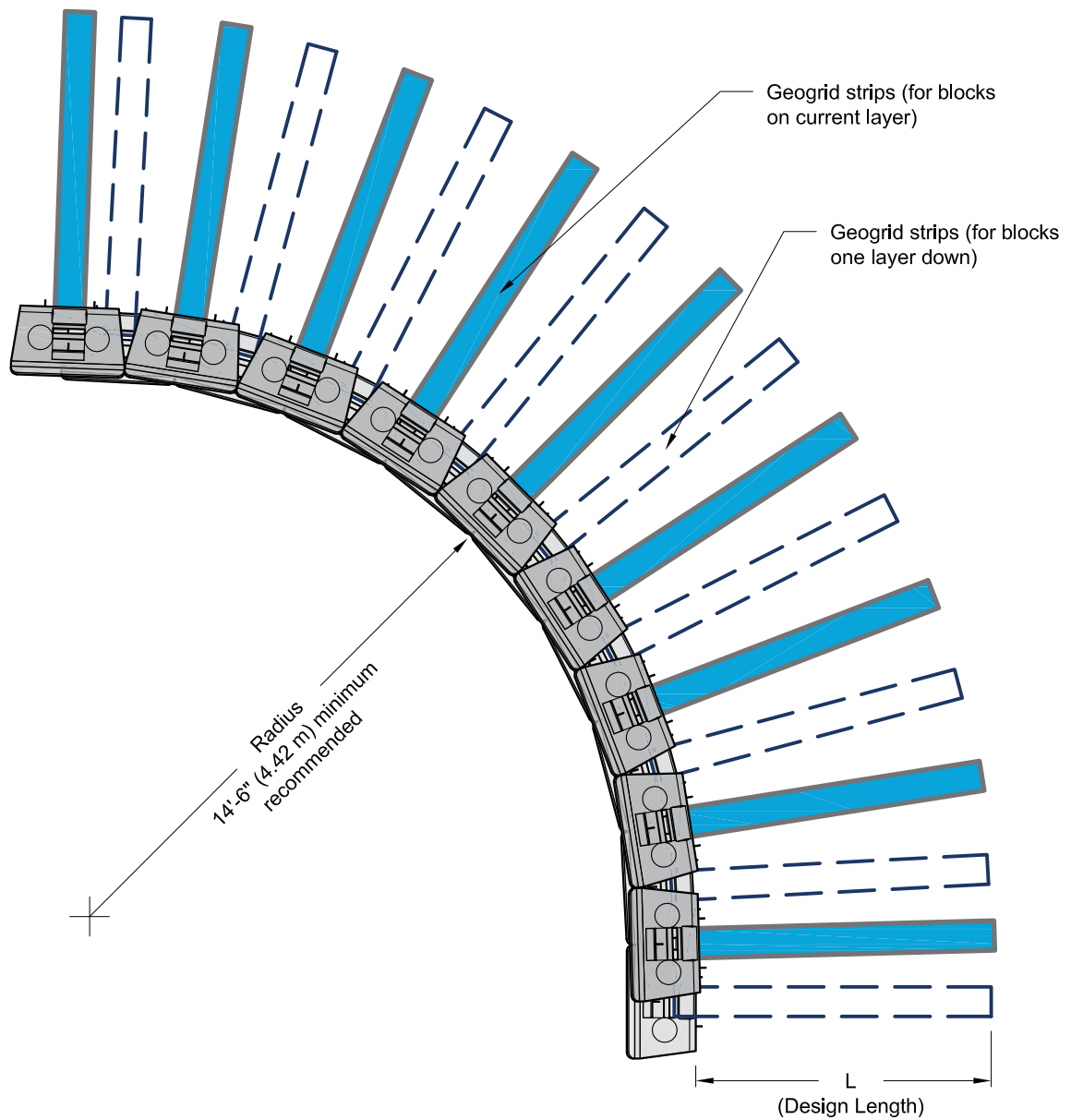

This drawing is for reference only. Determination of the suitability and/or manner of use of any details contained in this document is the sole responsibility of the design engineer of record. Final project designs, including all construction details, shall be prepared by a licensed professional engineer using the actual conditions of the proposed site.

Geogrid Layout for 90° Inside Corner

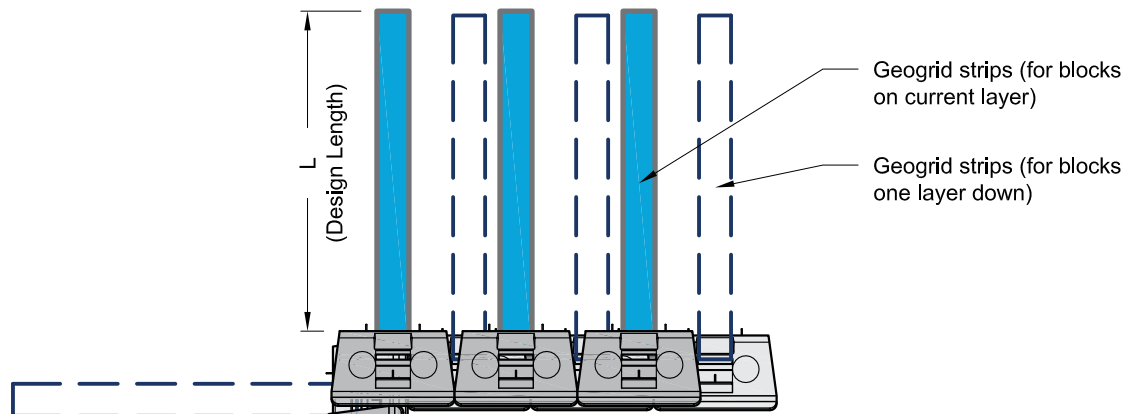

Top View

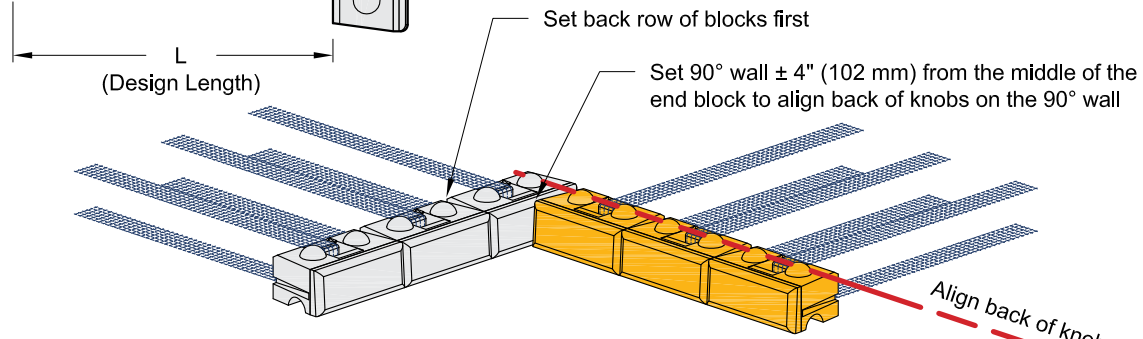

Block placement - First row

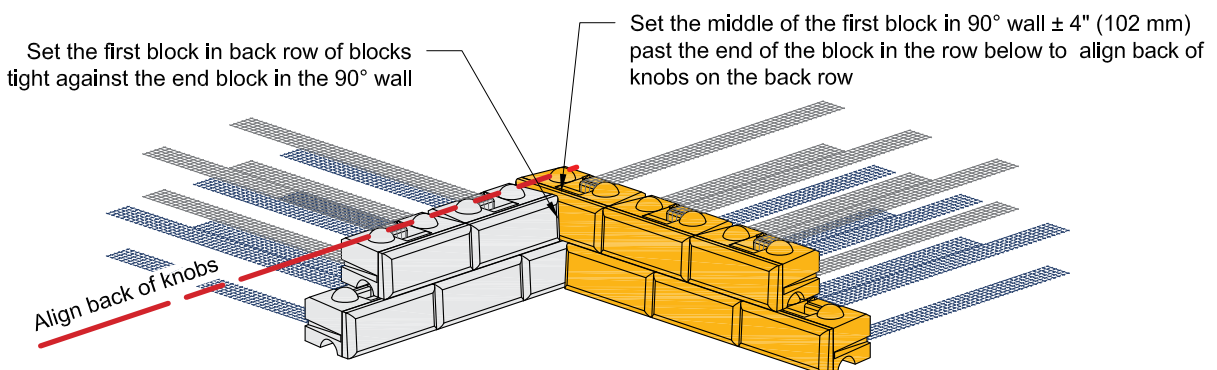

Block placement - Second row

This drawing is for reference only. Determination of the suitability and/or manner of use of any details contained in this document is the sole responsibility of the design engineer of record. Final project designs, including all construction details, shall be prepared by a licensed professional engineer using the actual conditions of the proposed site.

Geogrid Layout for 90° Outside Corner

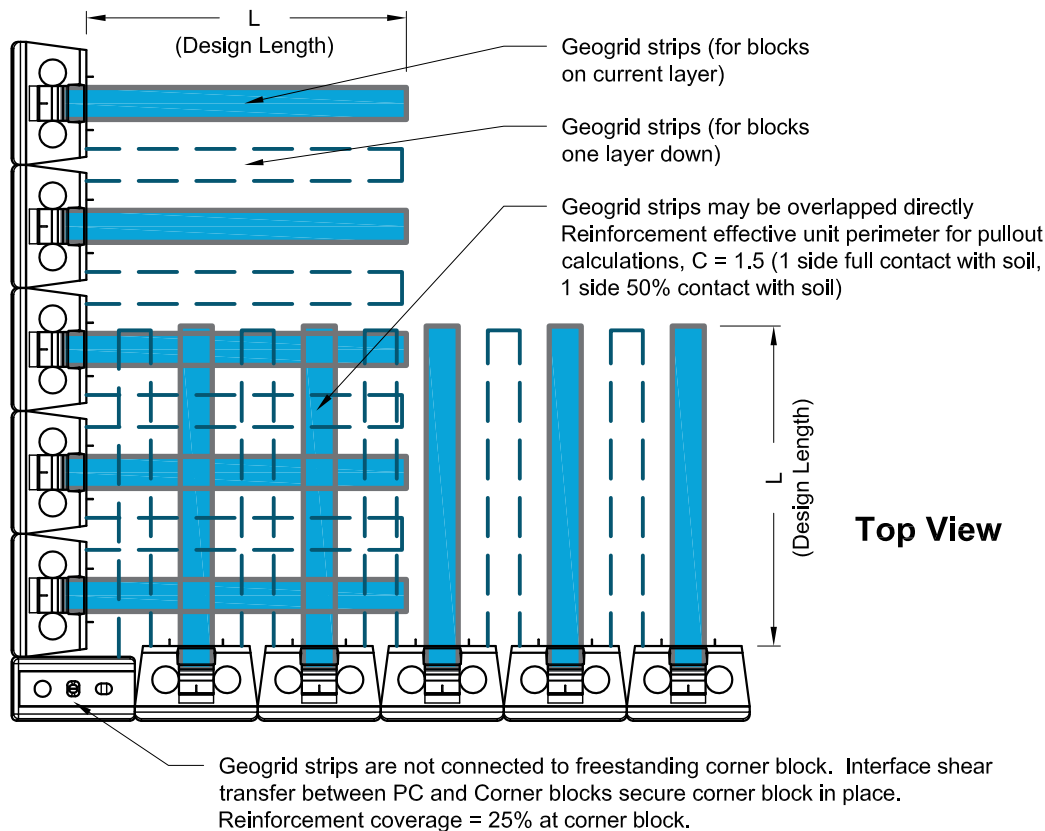

Block Layout for 90° Outside Corner

The top row of blocks are shown in red. They have been cutout in line with their bottom grooves to show how they fit with the knobs on the bottom row of block. The geogrid strips are not shown for clarity.

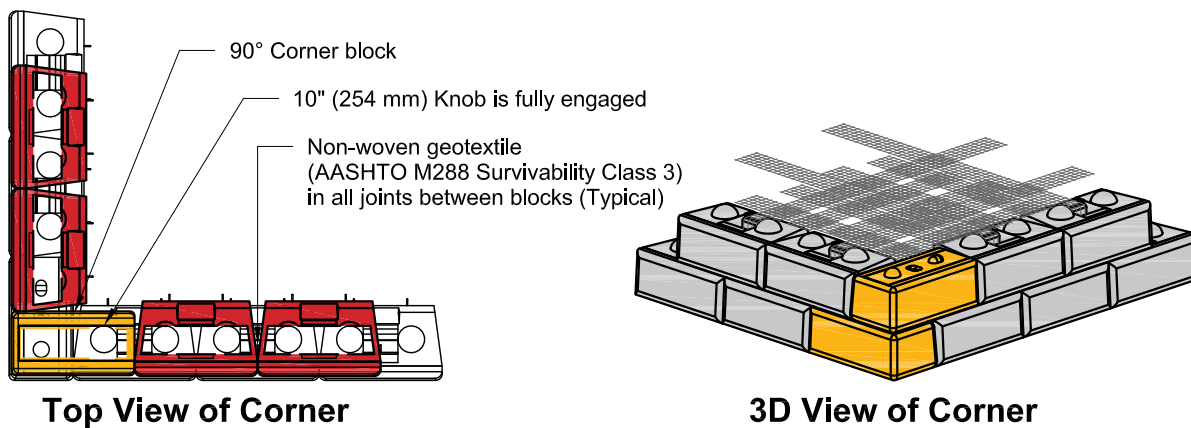

This drawing is for reference only. Determination of the suitability and/or manner of use of any details contained in this document is the sole responsibility of the design engineer of record. Final project designs, including all construction details, shall be prepared by a licensed professional engineer using the actual conditions of the proposed site.

Sample Plan and Profile Gravity Wall

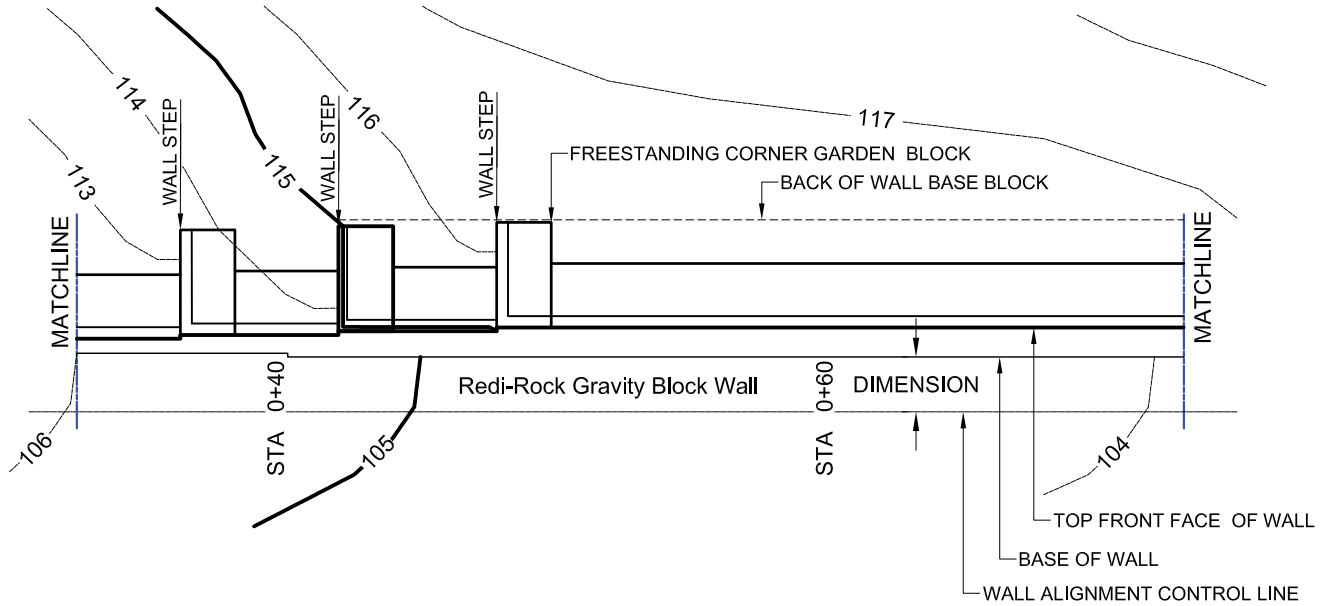

LEGEND:

- BLOCK SERIES (RETAINING, FREESTANDING, ACCESSORY)
- BLOCK SIZE (28,41, & 60)
- R-41M — BLOCK TYPE (BOTTOM, MIDDLE, TOP or CORNER GARDEN)

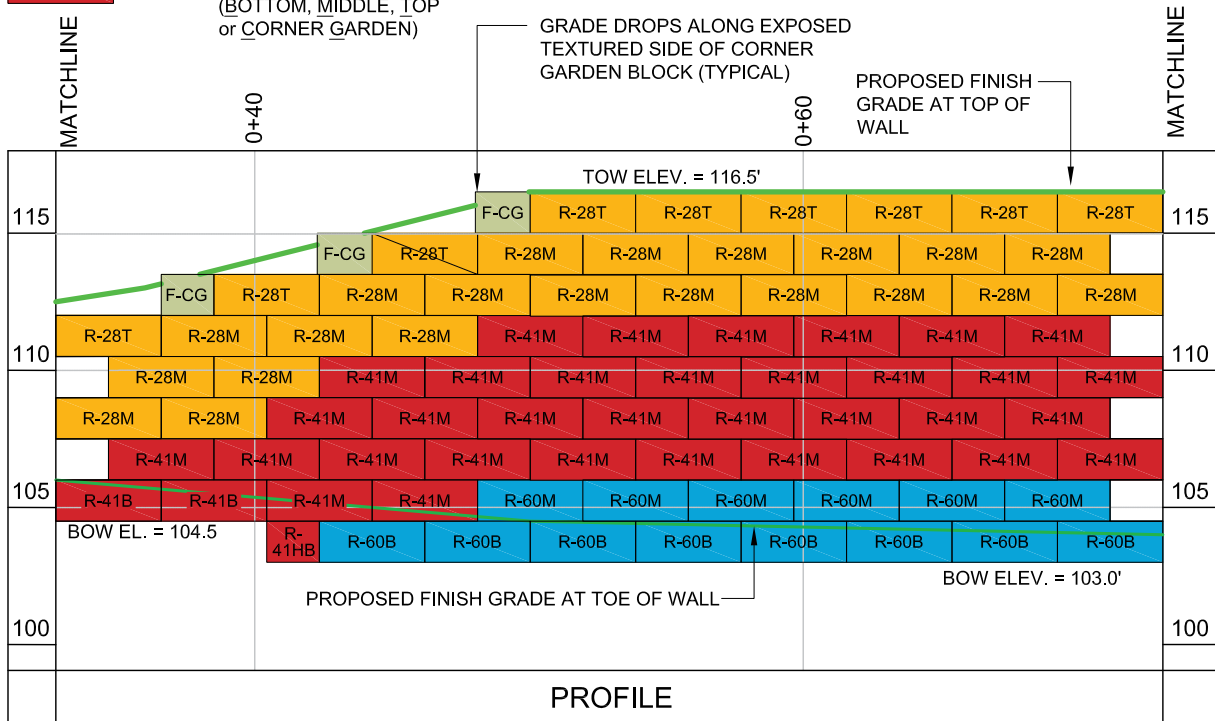

PROFILE

- This drawing is for reference only.
- Final designs for construction must be prepared by a registered Professional Engineer using the actual conditions of the proposed site.
- Final wall design must address both internal and external drainage and shall be evaluated by the Professional Engineer who is responsible for the wall design.

Sample Plan and Profile Positive Connection MSE Wall

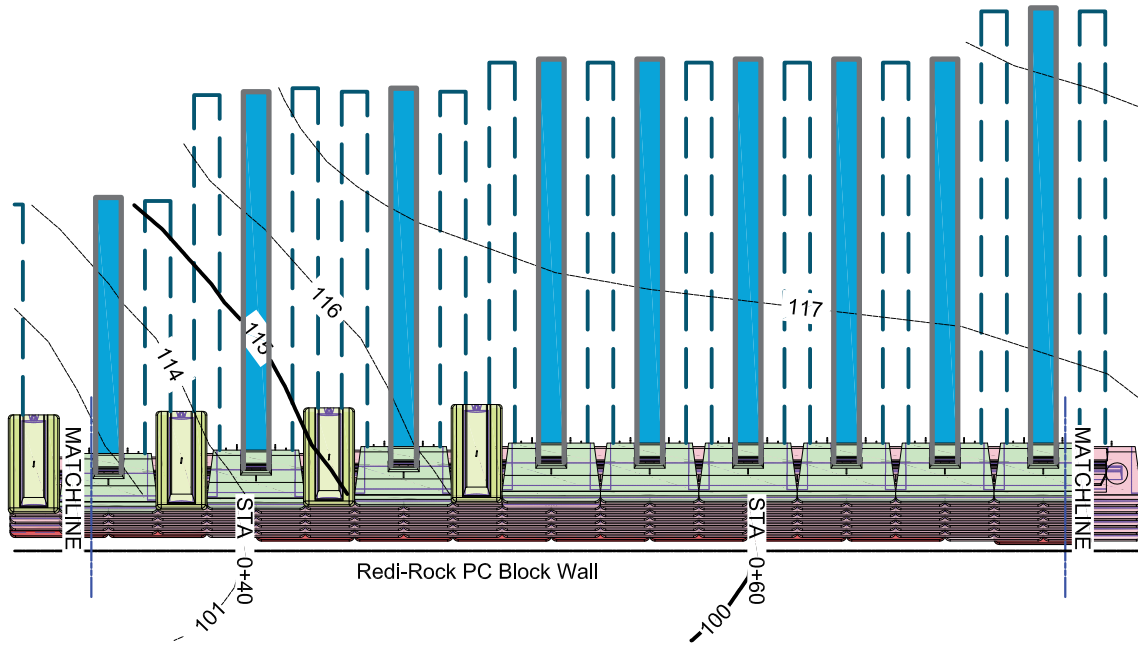

LEGEND:

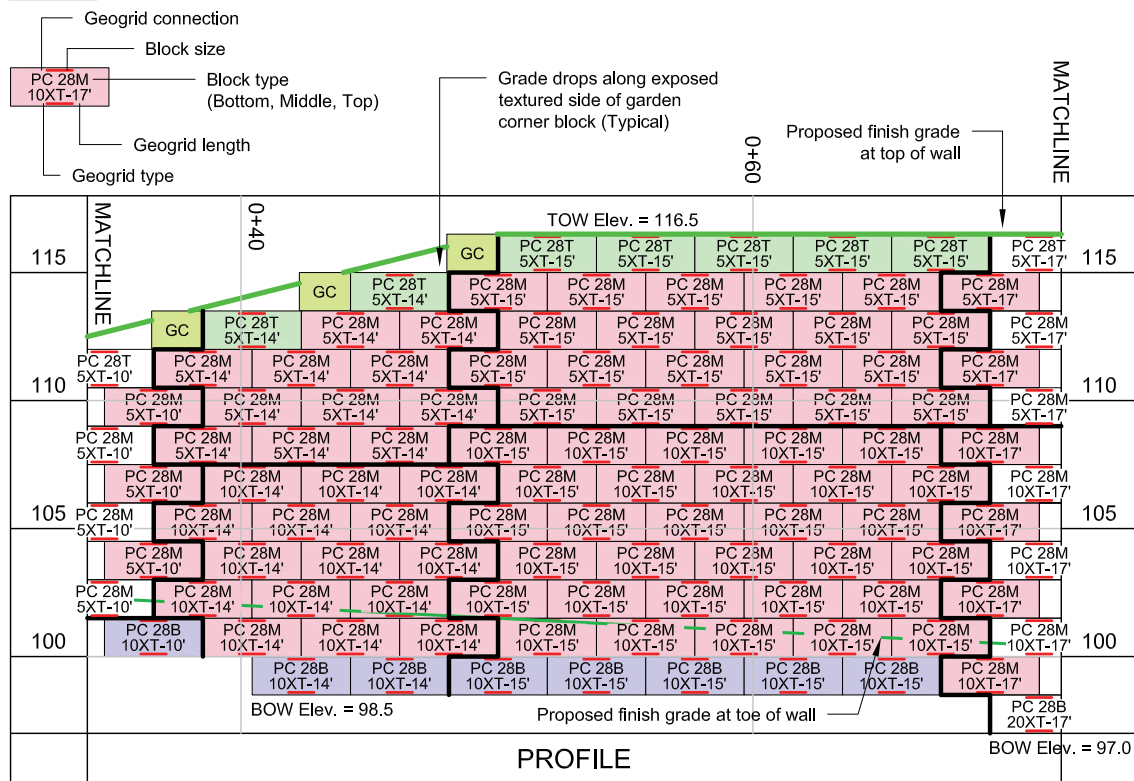

This drawing is for reference only. Determination of the suitability and/or manner of use of any details contained in this document is the sole responsibility of the design engineer of record. Final project designs, including all construction details, shall be prepared by a licensed professional engineer using the actual conditions of the proposed site.

Light Pole Base or Concrete Pile in Reinforced Soil Zone

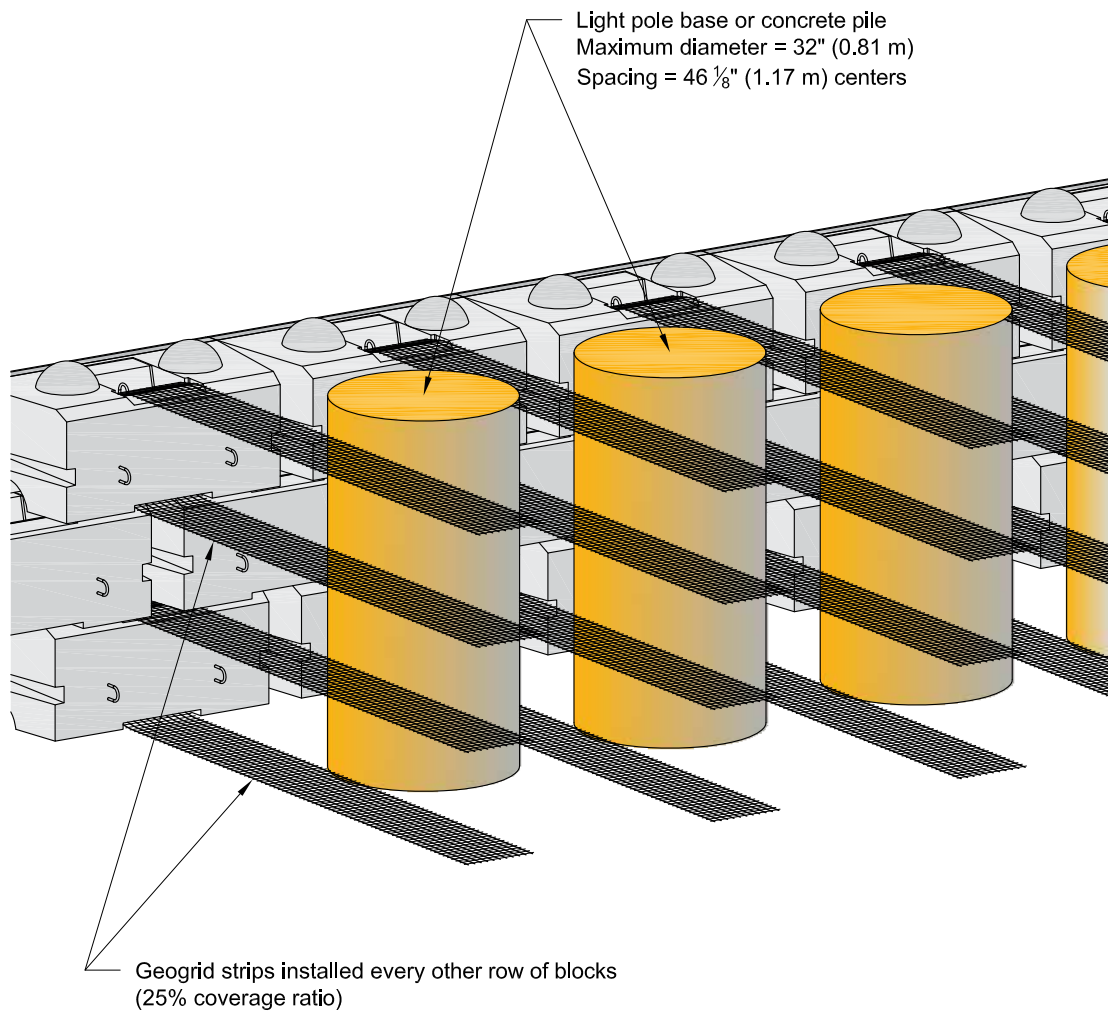

3D View from Back

This drawing is for reference only. Determination of the suitability and/or manner of use of any details contained in this document is the sole responsibility of the design engineer of record. Final project designs, including all construction details, shall be prepared by a licensed professional engineer using the actual conditions of the proposed site.

Manhole or Large Obstruction in Reinforced Soil Zone

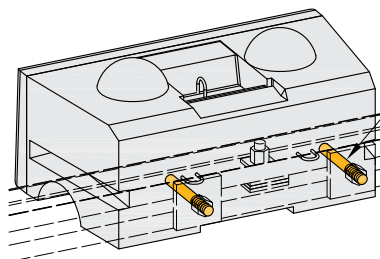
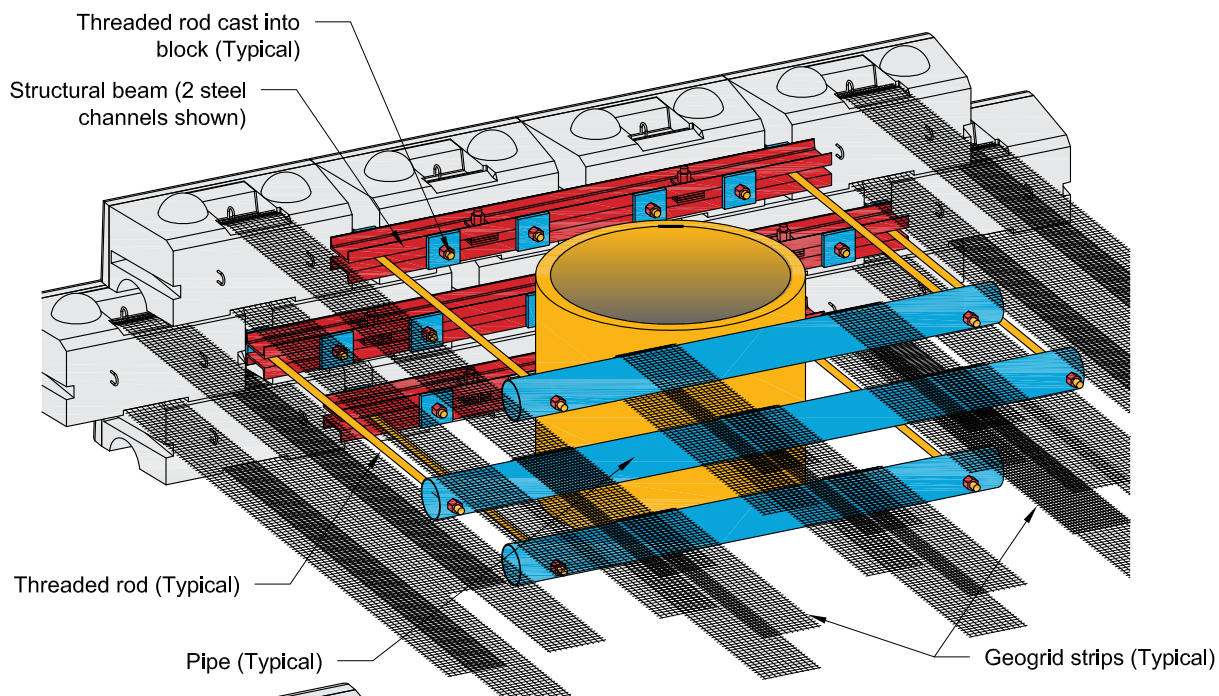

Block Detail

Steel structural elements to be sized and galvanized per engineer for project specific requirements.

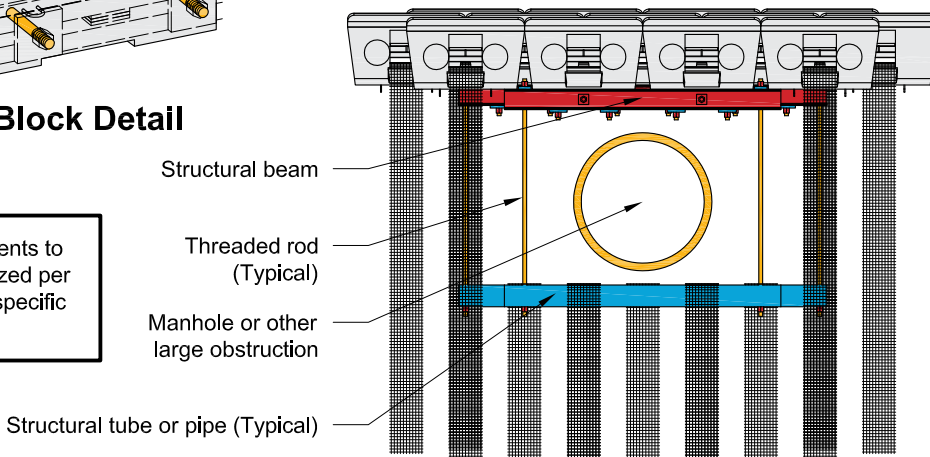

Top View

This drawing is for reference only. Determination of the suitability and/or manner of use of any details contained in this document is the sole responsibility of the design engineer of record. Final project designs, including all construction details, shall be prepared by a licensed professional engineer using the actual conditions of the proposed site.

Utilities in the Reinforced Soil Zone

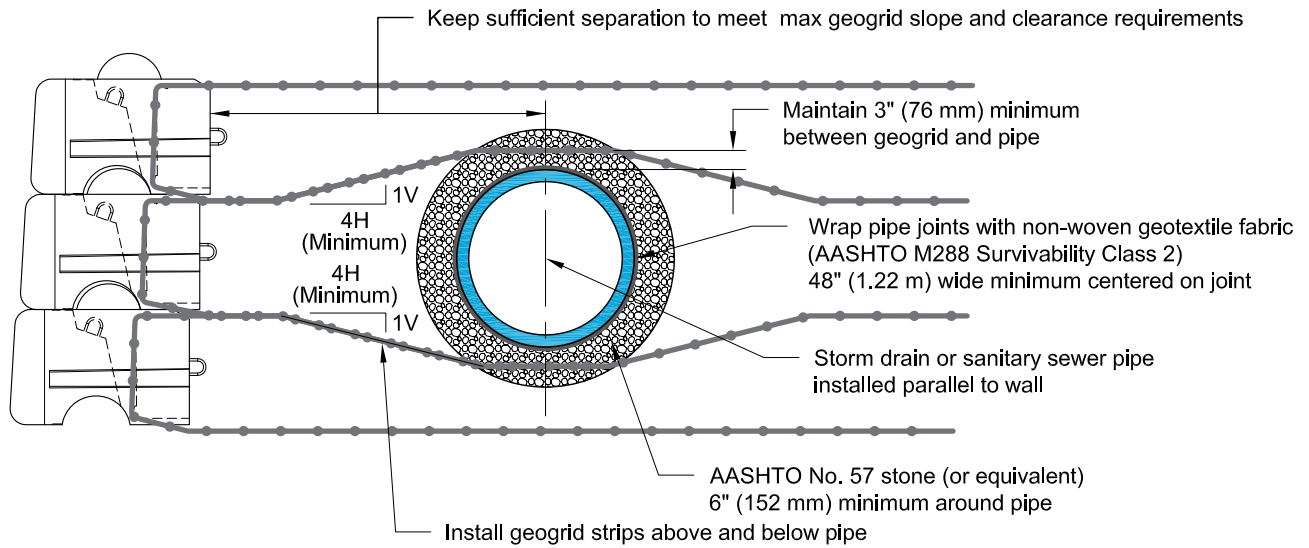

Storm or Sanitary Sewer Pipe

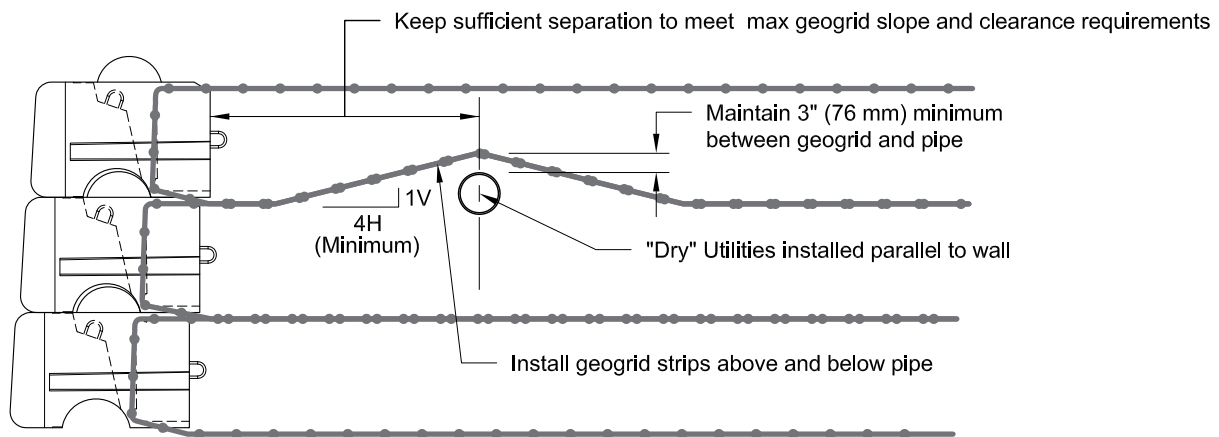

"Dry" Utilities (Electric, Gas, Telecommunications)

Redi-Rock International follows the recommendations of FHWA GEC 011 and discourages placing pipes or other horizontal obstructions behind the wall in the reinforced soil zone. Placing pipes in this zone could lead to maintenance problems and potential wall failure.

This drawing is for reference only. Determination of the suitability and/or manner of use of any details contained in this document is the sole responsibility of the design engineer of record. Final project designs, including all construction details, shall be prepared by a licensed professional engineer using the actual conditions of the proposed site.

Pipes Installed Through Wall - Perpendicular

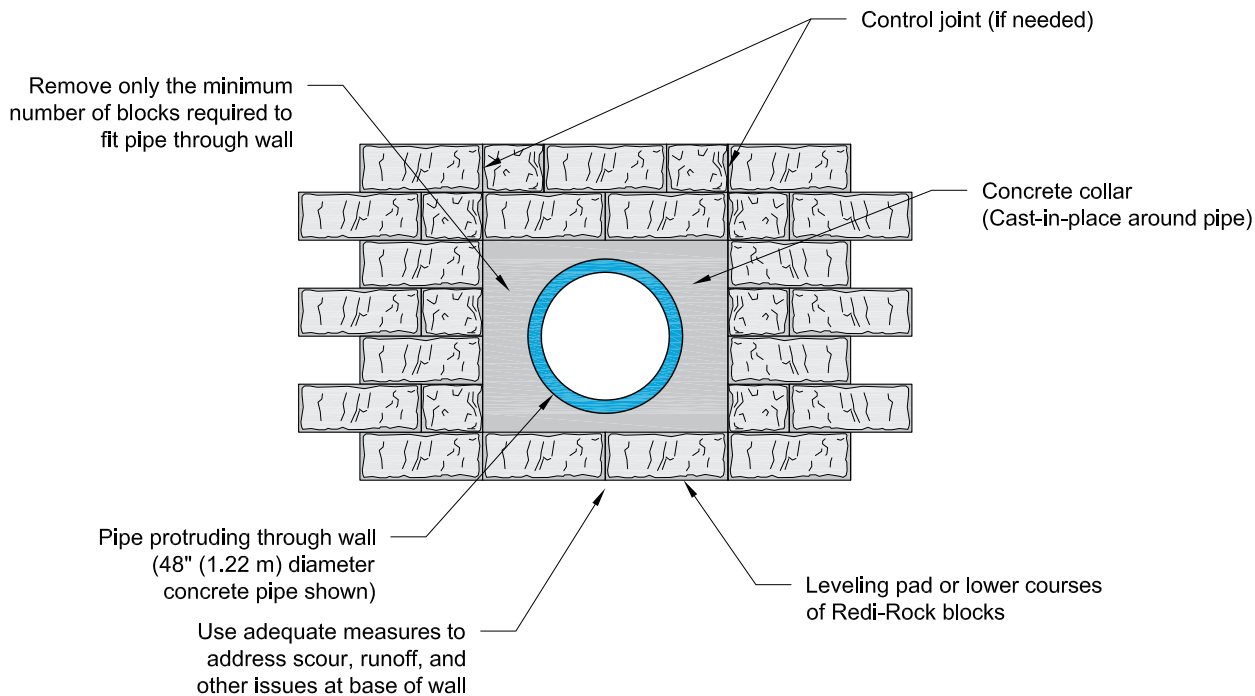

Plan View

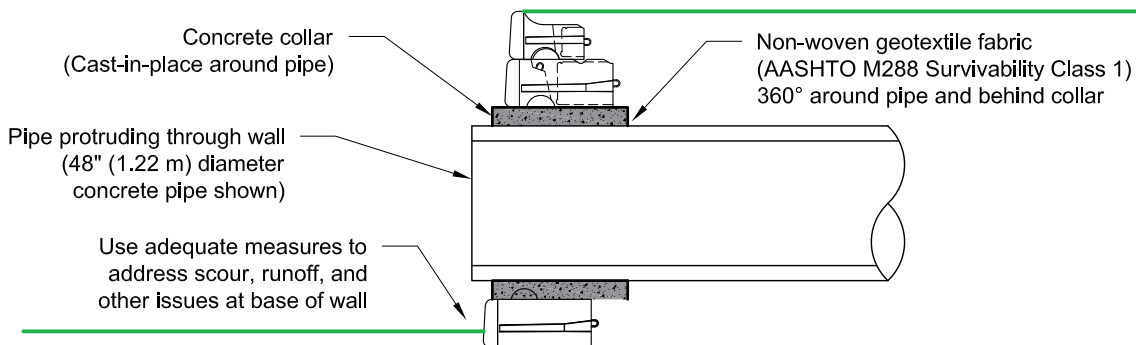

Section View

This drawing is for reference only. Determination of the suitability and/or manner of use of any details contained in this document is the sole responsibility of the design engineer of record. Final project designs, including all construction details, shall be prepared by a licensed professional engineer using the actual conditions of the proposed site.

Common Fence or Pedestrian Guard Connections

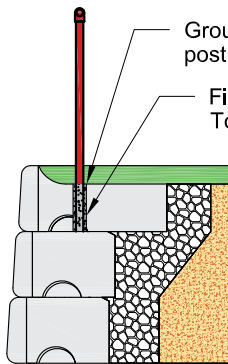
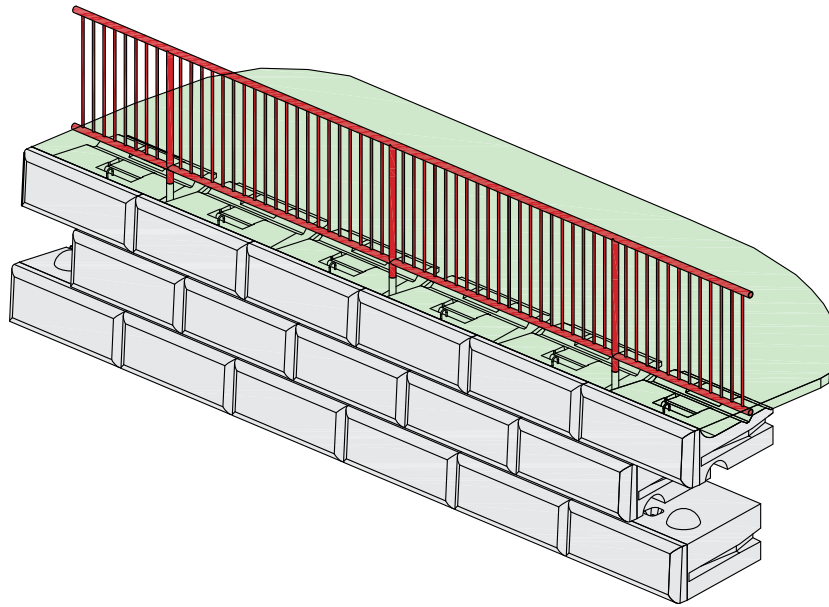

Grout fence or railing post in place
Field core into Top block

**Grouted Connection
(1 Block)**

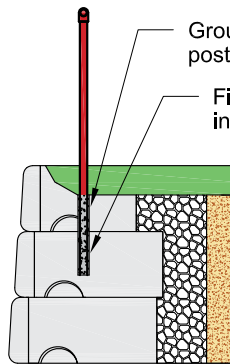

Grout fence or railing post in place
Field core into block in second course

**Grouted Connection
(2 Blocks)**

These generic pedestrian guard and fence details show a few potential options for their installation on the top of a Redi-Rock retaining wall. It is the design engineer's responsibility to fully design and detail the connection of the guard posts to the retaining wall blocks and assure acceptable resistance to the applied forces. Redi-Rock blocks are plain concrete, without steel reinforcement.

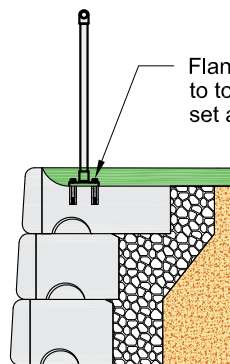

Flange base plate attached to top block with adhesive set anchor bolts

Flange Bolted Connection

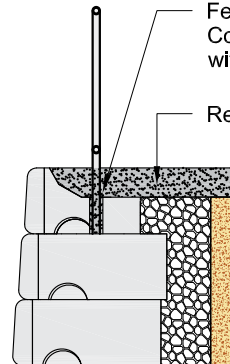

Fence or railing post
Core and grout or connect with flanged base plate
Reinforced concrete sidewalk

Moment Slab Connection

This drawing is for reference only. Determination of the suitability and/or manner of use of any details contained in this document is the sole responsibility of the design engineer of record. Final project designs, including all construction details, shall be prepared by a licensed professional engineer using the actual conditions of the proposed site.

Common Fence or Pedestrian Guard Connection Locations

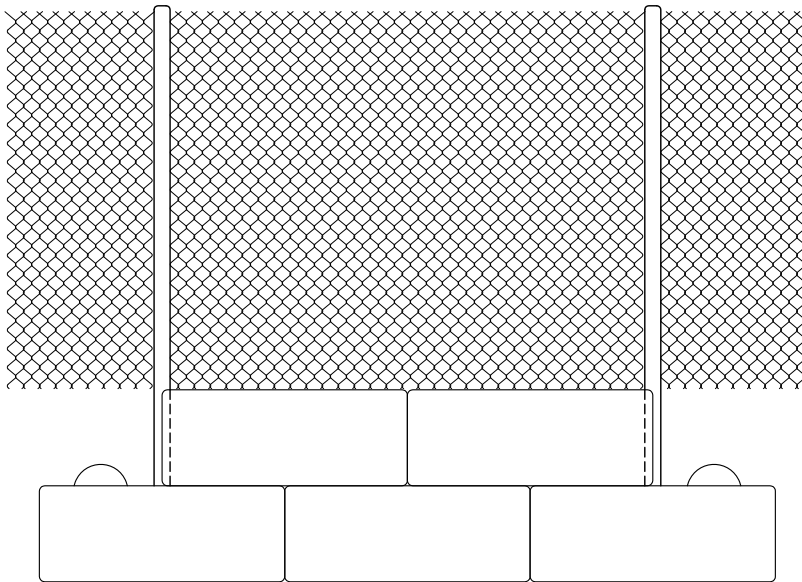

Front View

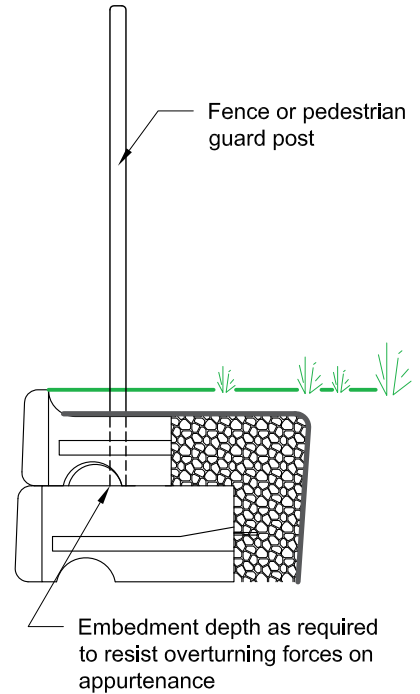

Side View

Connection Option #1
Anchor into the top block

- Consider block lengths when determining post spacing
- Weight of a single block available to resist overturning forces

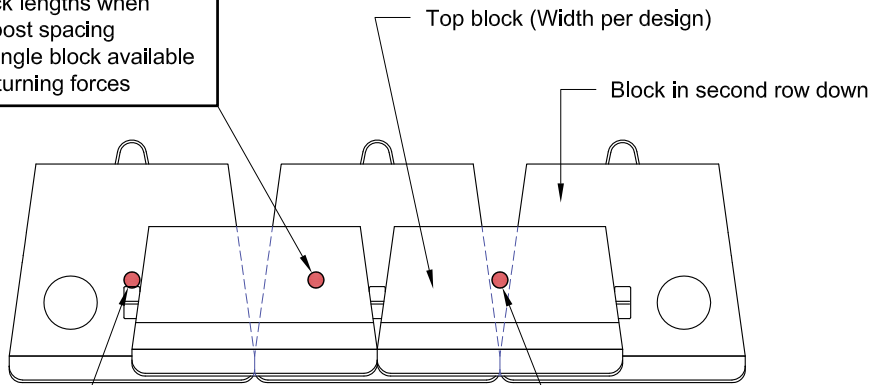

Top View

Connection Option #2
Grout posts in v-shaped opening between top blocks

- Spacing in multiples of 46 1/8" (1172 mm)
- Weight of a 2 adjacent blocks available to resist overturning forces

Connection Option #3
Core through top block and grout posts in V-shaped opening between lower blocks

- Spacing in multiples of 46 1/8" (1172 mm)
- Weight of a 2 adjacent blocks on second level down and 3 top row blocks available to resist overturning forces

This drawing is for reference only. Determination of the suitability and/or manner of use of any details contained in this document is the sole responsibility of the design engineer of record. Final project designs, including all construction details, shall be prepared by a licensed professional engineer using the actual conditions of the proposed site.

Freestanding Bond Beam at Top of Wall

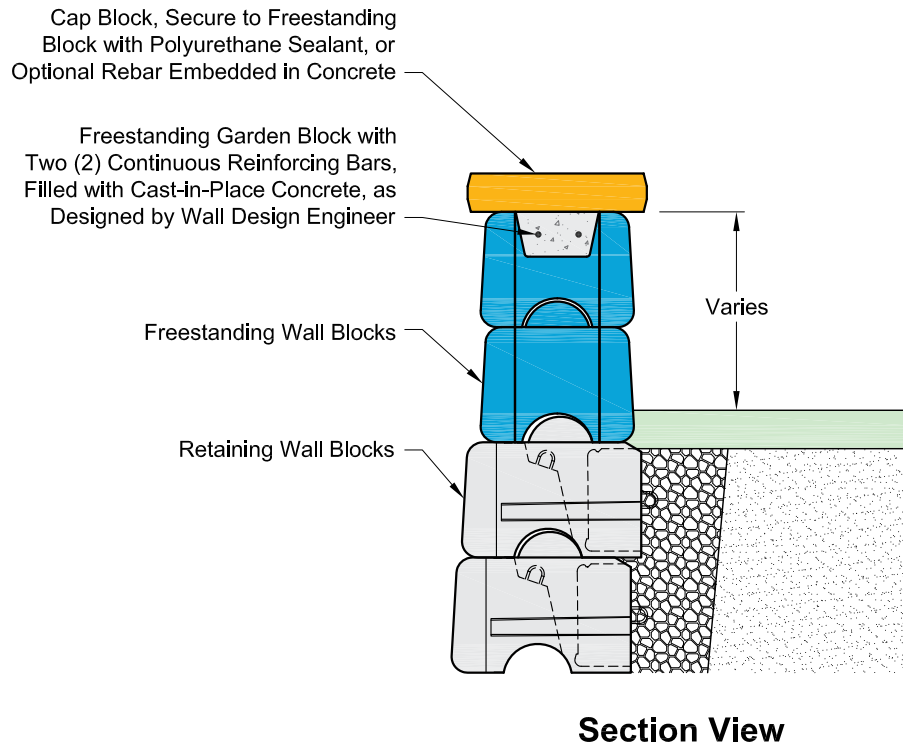

Sealant Adhesive: One-component, highly flexible, non-priming, gun grade, high performance elastomeric polyurethane sealant shall have movement of plus or minus 25% per ASTM C719, tensile strength greater than 200 psi (1.4 MPa) per ASTM D412, and adhesion to peel on concrete greater than 20 PLI per ASTM C794. Apply sealant in one and one half-inch (1.5") (38 mm) diameter round "hersey kiss" shaped dollops located in two rows at the top of the Freestanding blocks at 8" (203 mm) on center.

This drawing is for reference only. Determination of the suitability and/or manner of use of any details contained in this document is the sole responsibility of the design engineer of record. Final project designs, including all construction details, shall be prepared by a licensed professional engineer using the actual conditions of the proposed site.

Typical Cantilever Wall Section

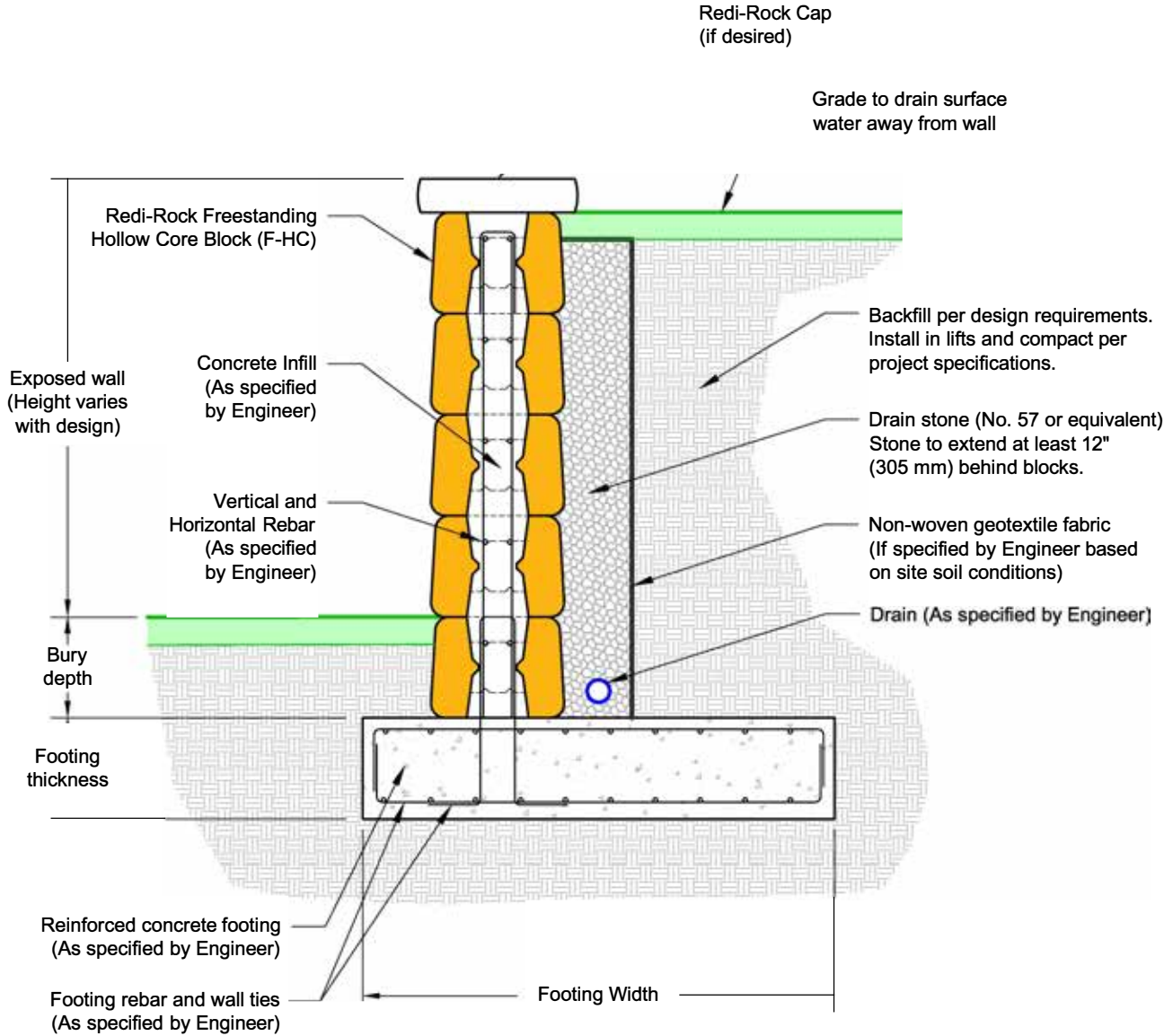

This drawing is for reference only. Determination of the suitability and/or manner of use of any details contained in this document is the sole responsibility of the design engineer of record. Final project designs, including all construction details, shall be prepared by a licensed professional engineer using the actual conditions of the proposed site. Final wall design must address both internal and external drainage and all modes of wall stability.

Freestanding Block Continuous Corner Detail

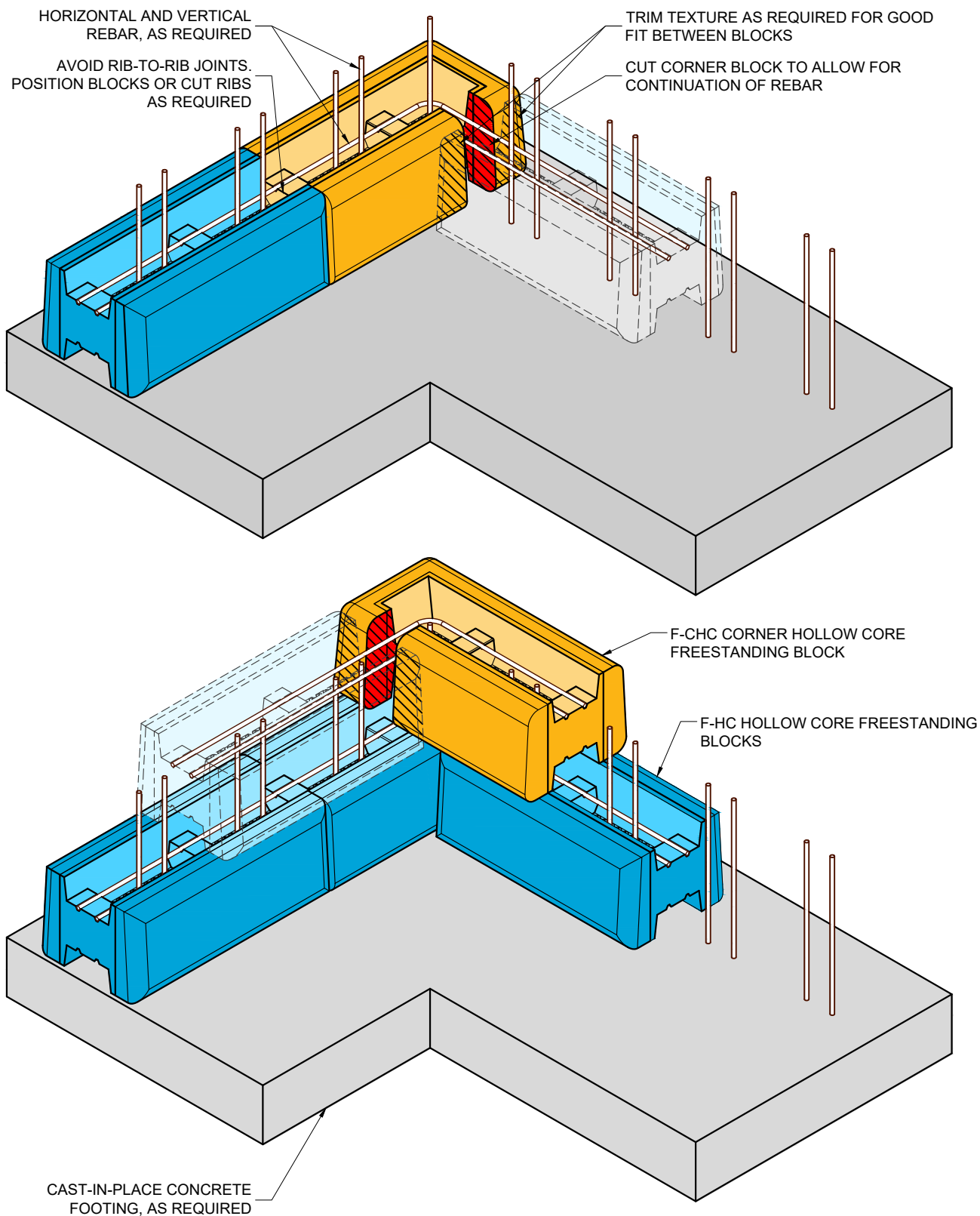

Freestanding Block Coping with Fence Attachment

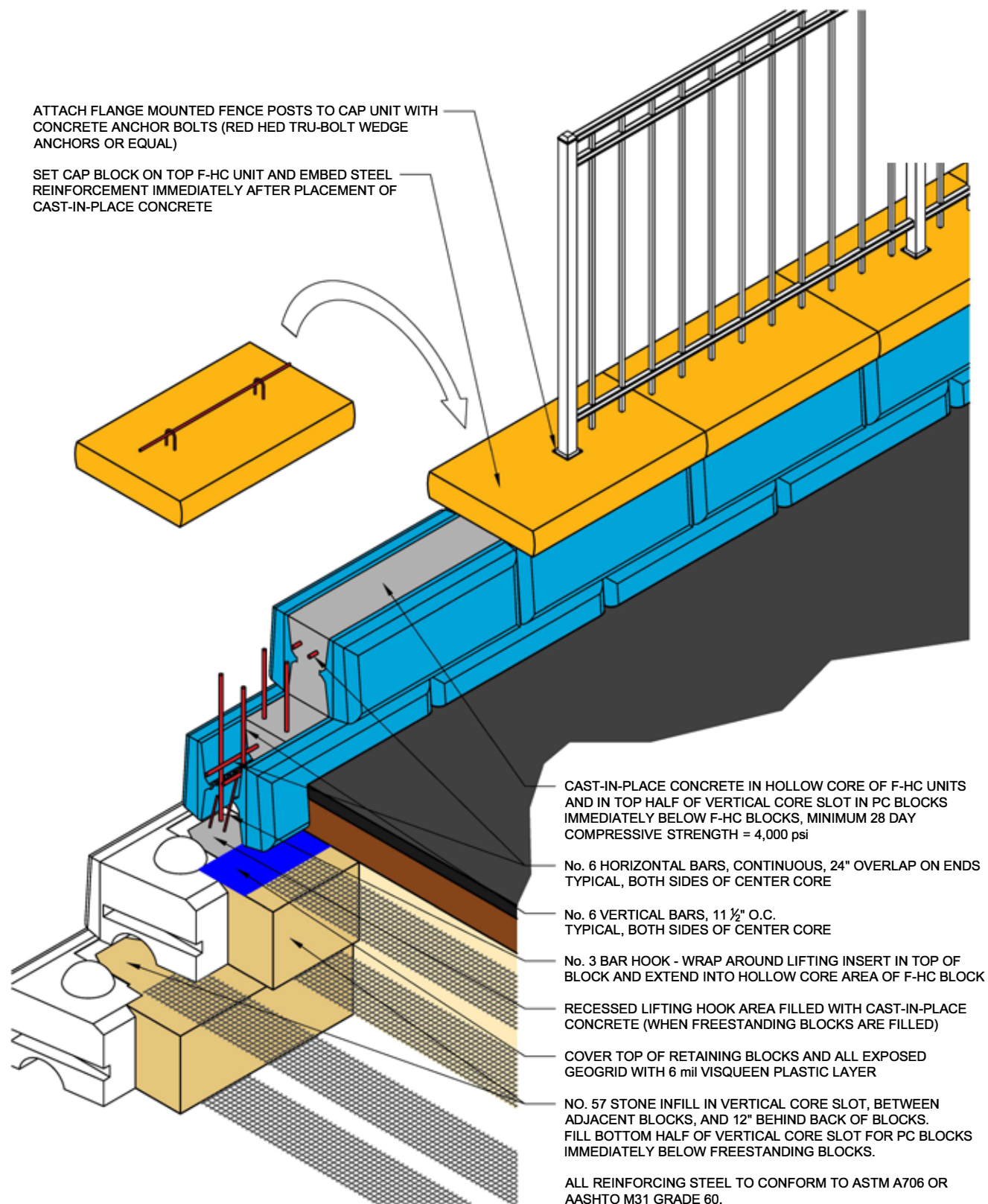

Freestanding Block Coping with Fence Attachment

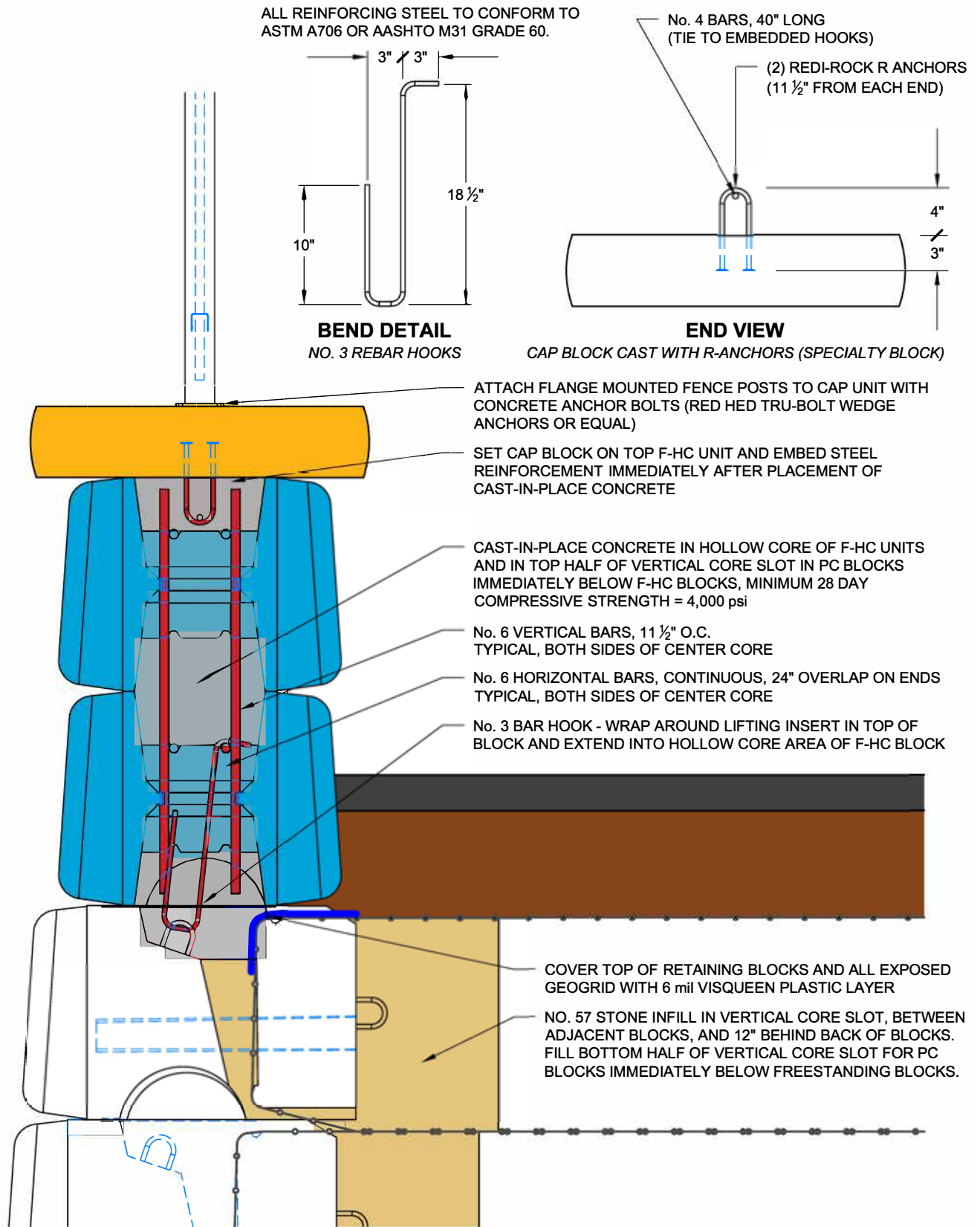

Post and Beam Guardrail

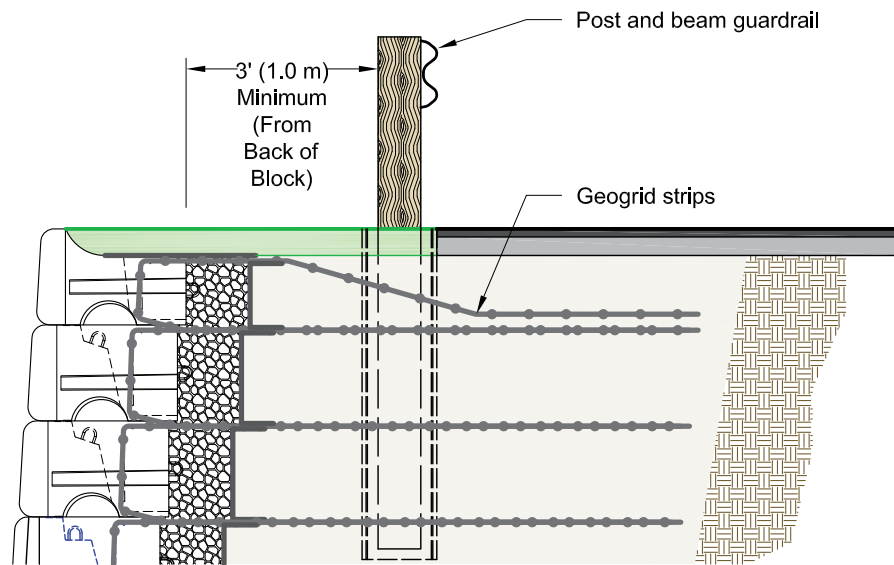

Section View

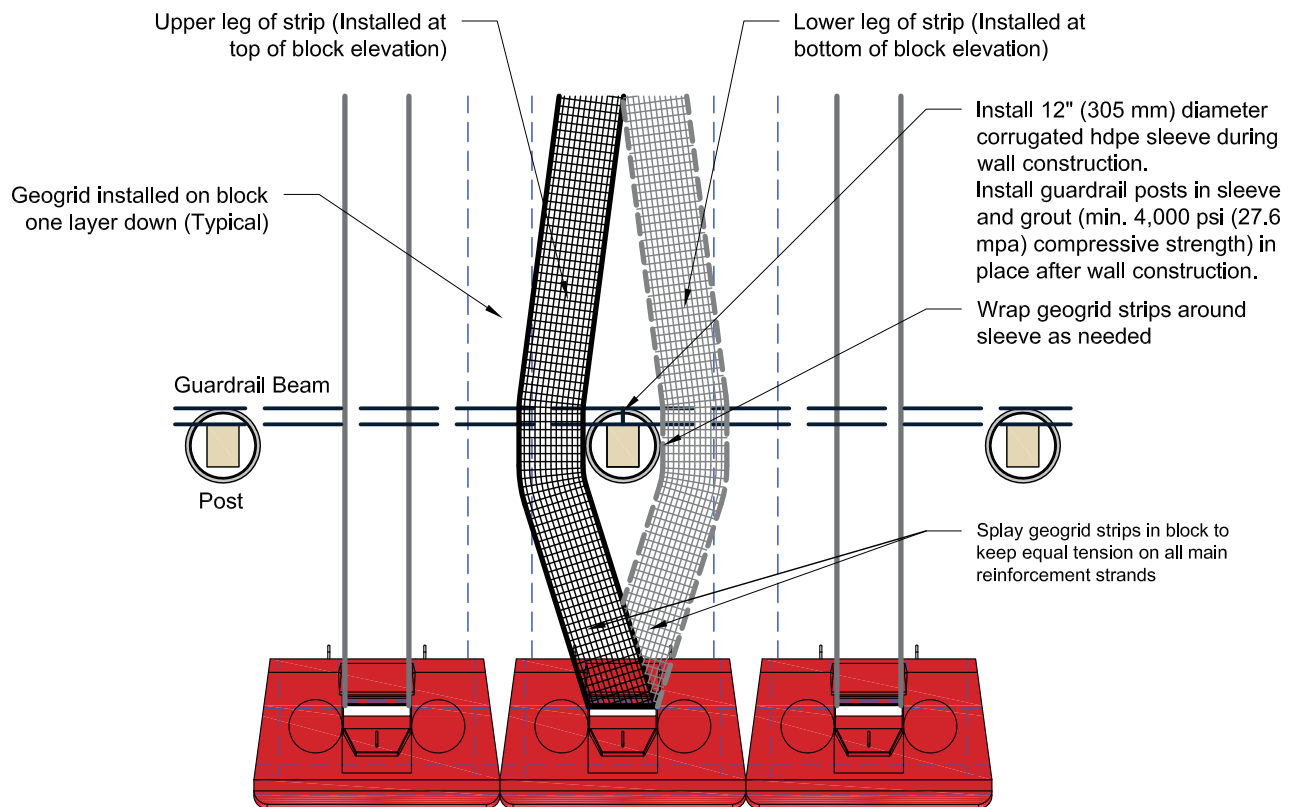

Top View

This drawing is for reference only. Determination of the suitability and/or manner of use of any details contained in this document is the sole responsibility of the design engineer of record. Final project designs, including all construction details, shall be prepared by a licensed professional engineer using the actual conditions of the proposed site.

Cast-in-Place Moment Slab Traffic Barrier - Flat Grade Installation

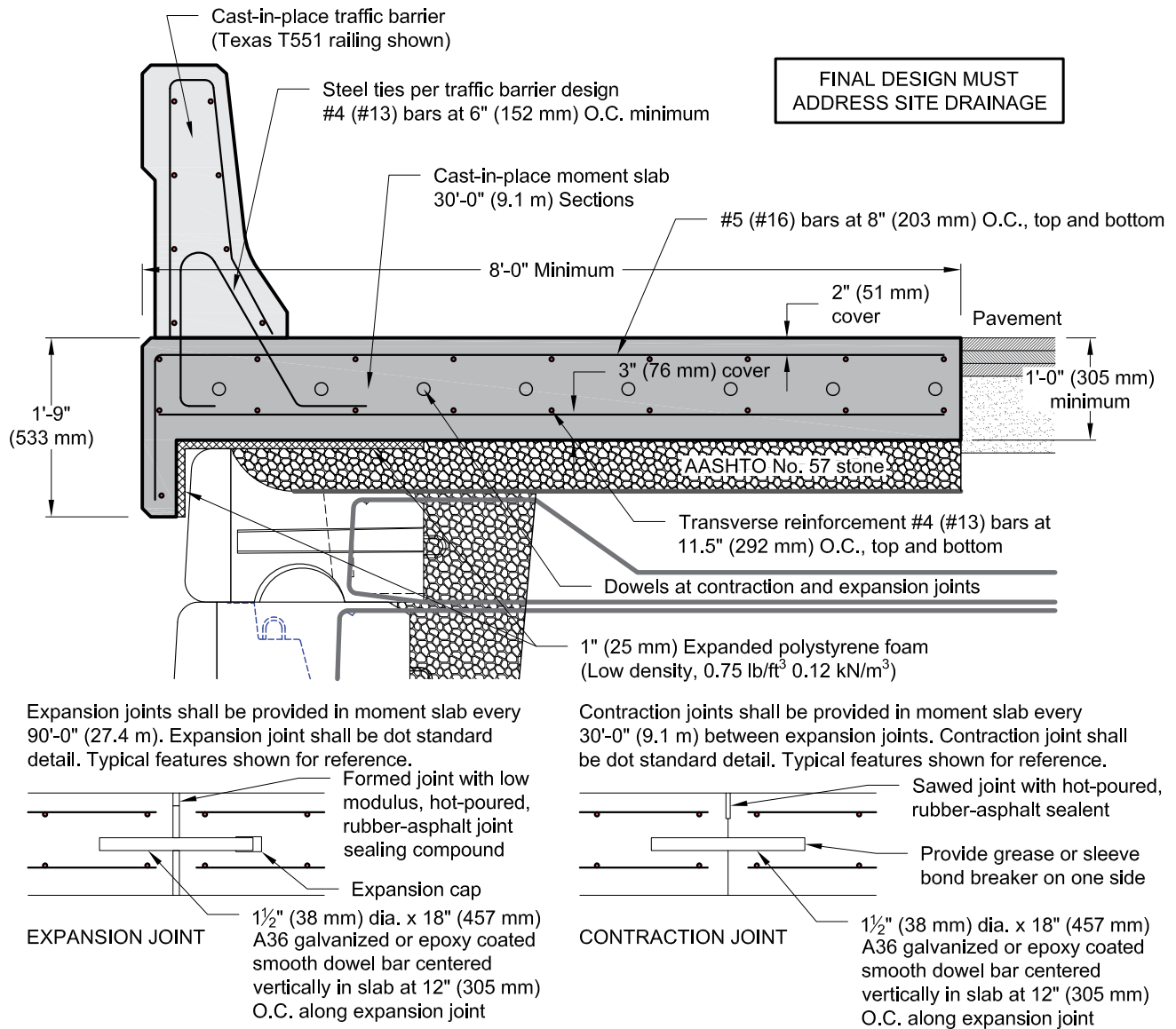

Materials

Concrete for cast-in-place barrier and moment slab shall be dot standard structure mix. Minimum 28 day compressive strength shall be 4,000 psi (27.6 mpa) or higher as specified. Reinforcing steel shall conform to ASTM A706 or AASHTO M31 Grade 60 (420 MPa).

Design

Moment slab shown is dimensioned based on an equivalent static load of 10,000 lbs (44.5 kN) per NCHRP Report 663. Moment slab reinforcement shown is based on AASHTO LRFD Bridge Design Specifications, 5th edition, 2010, TL-4 loading detailed in Table A13.2.1.

The selection and use of this detail, while designed in accordance with generally accepted engineering principles and practices, is the sole responsibility of the registered professional engineer in charge of the project.

This drawing is for reference only. Determination of the suitability and/or manner of use of any details contained in this document is the sole responsibility of the design engineer of record. Final project designs, including all construction details, shall be prepared by a licensed professional engineer using the actual conditions of the proposed site.

Cast-in-Place Moment Slab Traffic Barrier - Sloping Installation

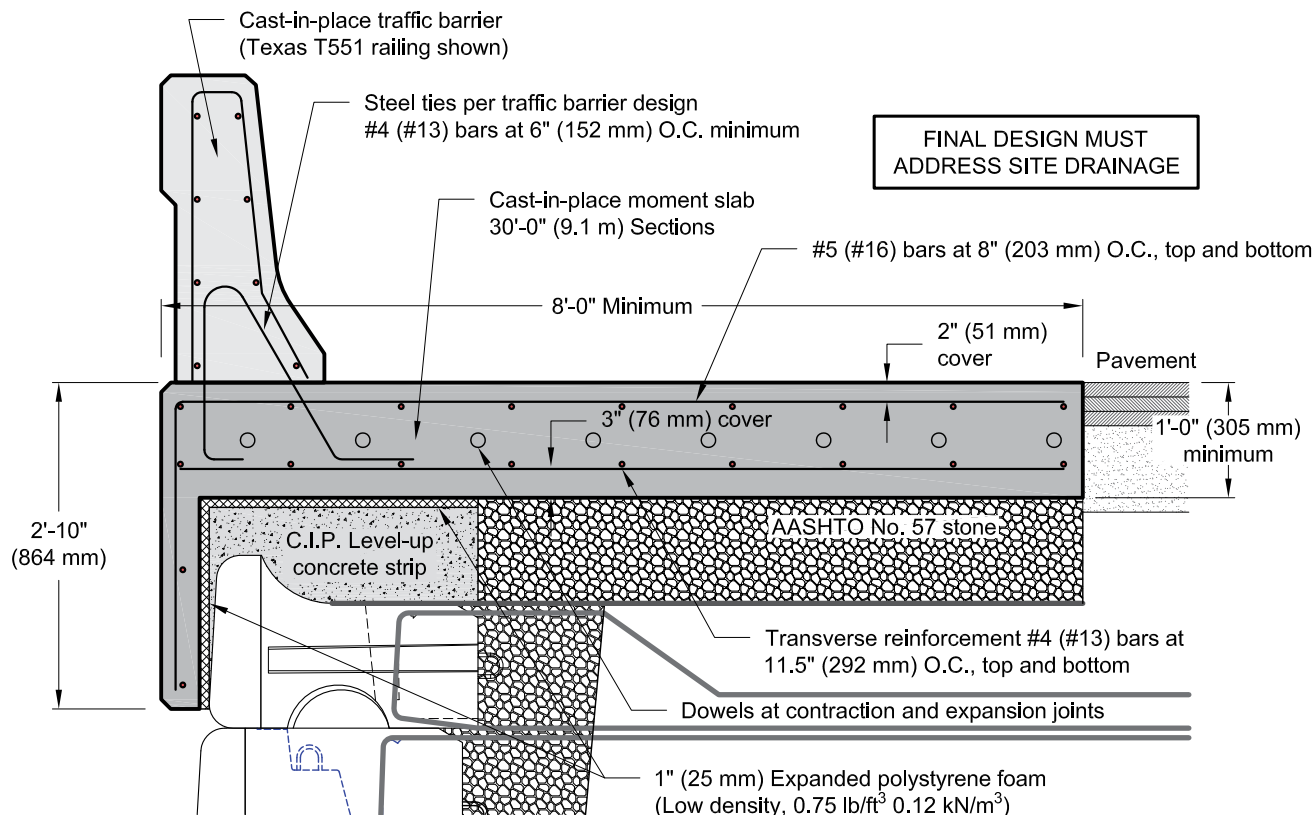

Expansion joints shall be provided in moment slab every 90'-0" (27.4 m). Expansion joint shall be dot standard detail. Typical features shown for reference.

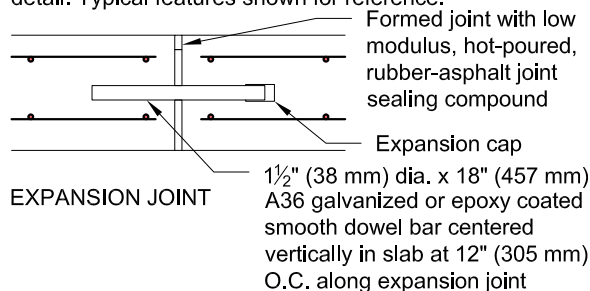

Materials

Concrete for cast-in-place barrier and moment slab shall be dot standard structure mix. Minimum 28 day compressive strength shall be 4,000 psi (27.6 mpa) or higher as specified. Cast-In-Place level up concrete shall be manufactured in accordance with ASTM C94. Minimum 28 day compressive strength shall be 3,500 psi (24.1 MPa) or higher as specified. Reinforcing steel shall conform to ASTM A706 or AASHTO M31 Grade 60 (420 MPa).

Design

Moment slab shown is dimensioned based on an equivalent static load of 10,000 lbs (44.5 kN) per NCHRP Report 663. Moment slab reinforcement shown is based on AASHTO LRFD Bridge Design Specifications, 5th edition, 2010, TL-4 loading detailed in Table A13.2.1.

The selection and use of this detail, while designed in accordance with generally accepted engineering principles and practices, is the sole responsibility of the registered professional engineer in charge of the project.

This drawing is for reference only. Determination of the suitability and/or manner of use of any details contained in this document is the sole responsibility of the design engineer of record. Final project designs, including all construction details, shall be prepared by a licensed professional engineer using the actual conditions of the proposed site.

Contraction joints shall be provided in moment slab every 30'-0" (9.1 m) between expansion joints. Contraction joint shall be dot standard detail. Typical features shown for reference.

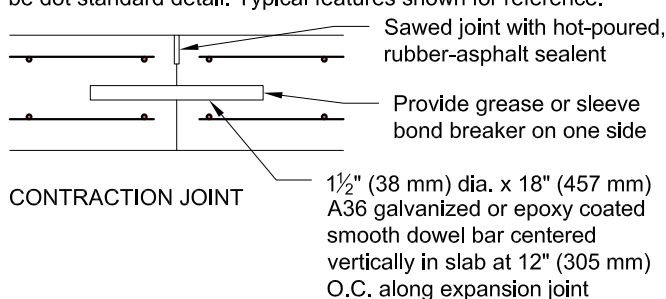

Precast Barrier Block

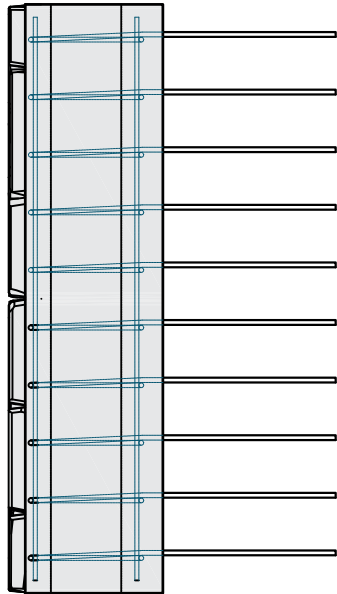

Top View

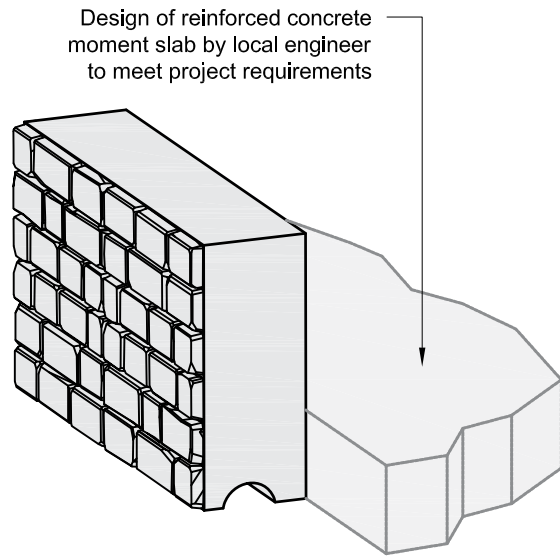

Isometric View

Rebar shown in barrier block meets AASHTO TL-3 loading requirements. Rebar design in barrier block is intended to be modified as necessary to meet other loading conditions. All reinforcing steel shall be grade 60 (414 MPa) deformed rebar. All concrete shall have a minimum 28 day compressive strength of 4000 psi (27.6 MPa).

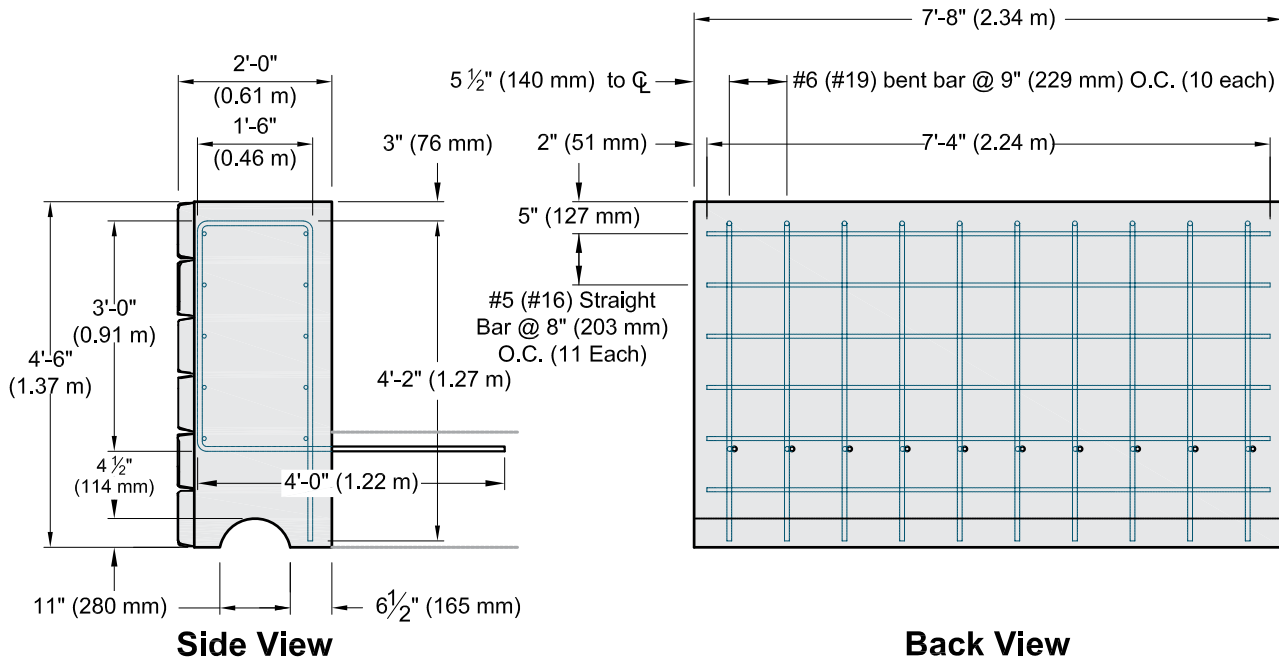

Side View

Back View

This drawing is for reference only. Determination of the suitability and/or manner of use of any details contained in this document is the sole responsibility of the design engineer of record. Final project designs, including all construction details, shall be prepared by a licensed professional engineer using the actual conditions of the proposed site.







Every Redi-Rock Manufacturer/Distributor is independently owned and operated.

©2019 Redi-Rock International