

WARRANTY: ALL TANKS MUST BE BACKFILLED AND COMPACTED PRIOR TO FILLING OR WARRANTY IS VOID.

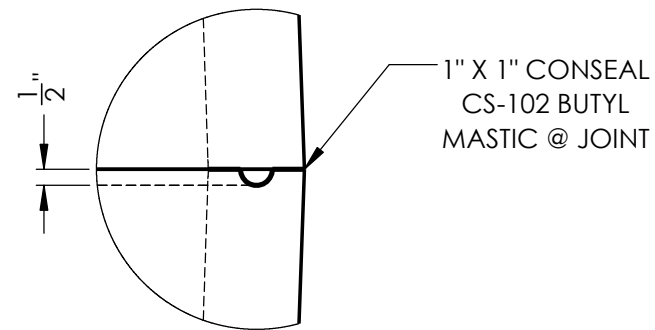

JOINT DETAIL A

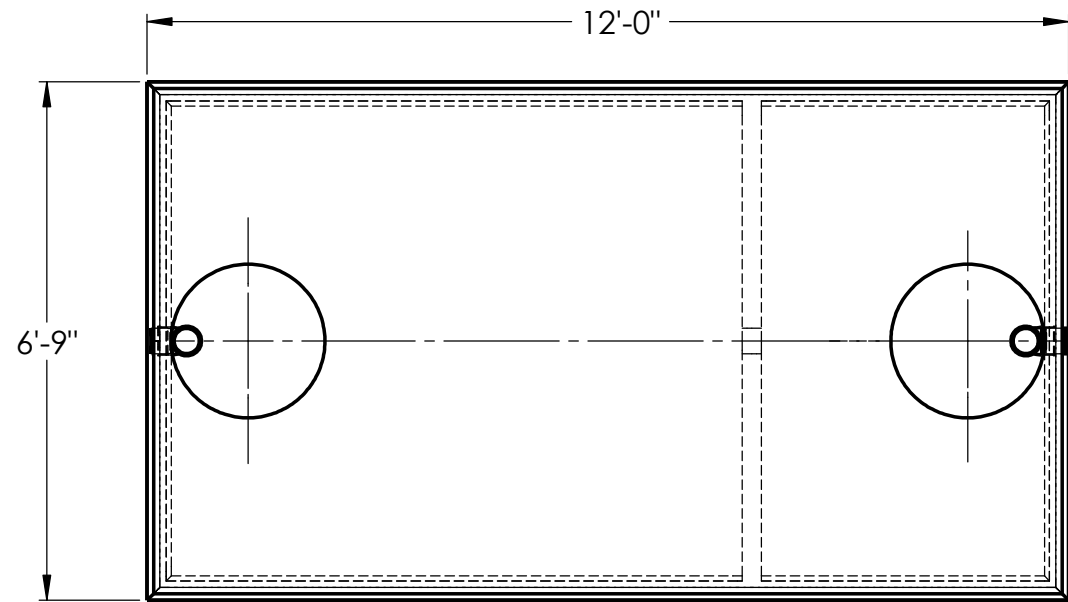
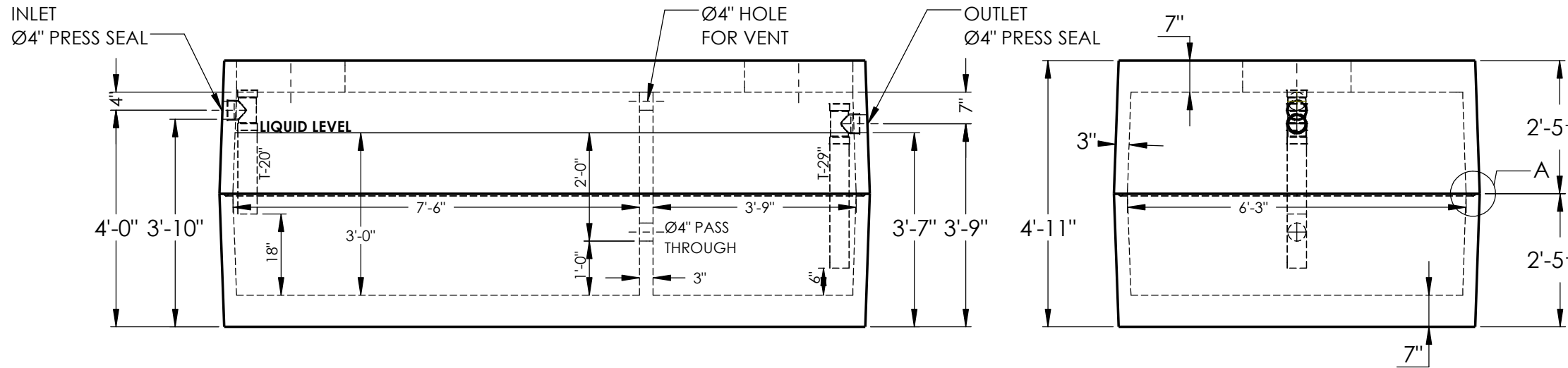
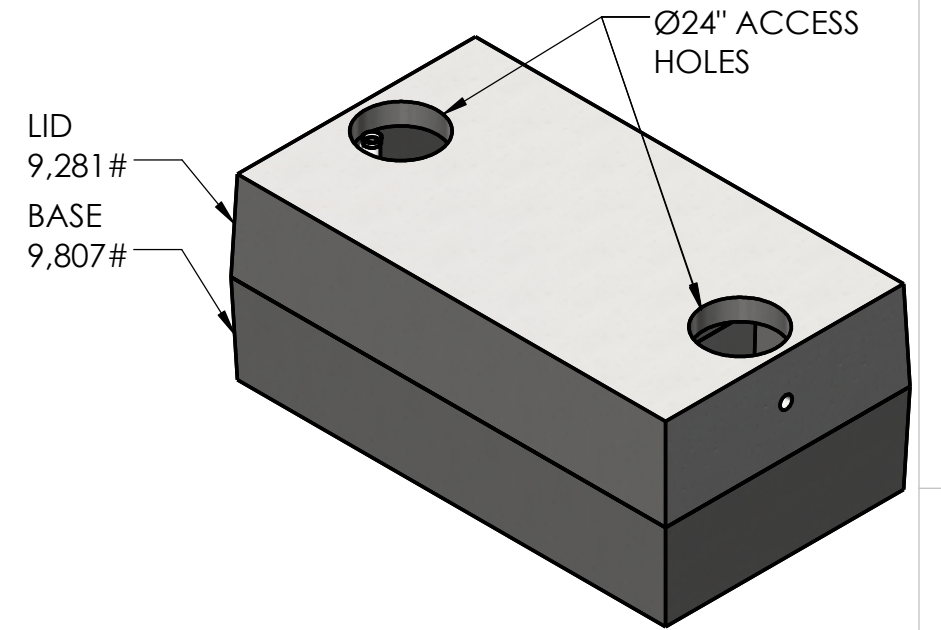

CONCRETE:

TANK CONSTRUCTION UTILIZES 4000 PSI CONCRETE AND GRADE 60 REBAR.

GALLON CALCS:

6'-3"W x 7'-6"L x 3'-0" x 7.48 = 1,052 GALLONS
 6'-3"W x 3'-9"L x 3'-0" x 7.48 = 526 GALLONS

RISERS:

PVC: Ø24" & FIBER COVER (TO GRADE)
 CONCRETE: Ø24" x 8" OR 12" (6" BELOW GRADE)

BEDDING:

4" PEA GRAVEL (NO WATER PRESENT)

EXCAVATION:

12" LARGER EACH WAY THAN TANK DIM.
 MAX COVER ON TOP 3'-0"

NOTES:

REINFORCEMENT:
 -#4 BARS @ 6" O.C.E.W. U-BARS IN TOP,
 (2) #4 EACH SIDE OF ACCESS
 -#4 BARS @ 6" O.C.E.W. IN SIDES
 -#4 BARS @ 6" O.C.E.W. U-BARS IN BOTTOM



**2215 E. BROOKLYN AVE
 SPOKANE, WA 99217
 TOLL FREE 1-800-888-4573
 (509) 325-4573 FAX (509) 325-5098
 SPOKANE - LEWISTON - YAKIMA
 www.wilbertprecast.com**

TITLE:

1500 GALLON DOUBLE COMPARTMENT
 2-PIECE OIL/WATER SEPARATOR - LOW PROFILE - HEAVY

SIZE

B

DWG. NO.

#1634OWTB 4"

SCALE:

NTS

DATE:

6/5/2018

DRAWN BY:
 CEB