

Top- Product #444-TH

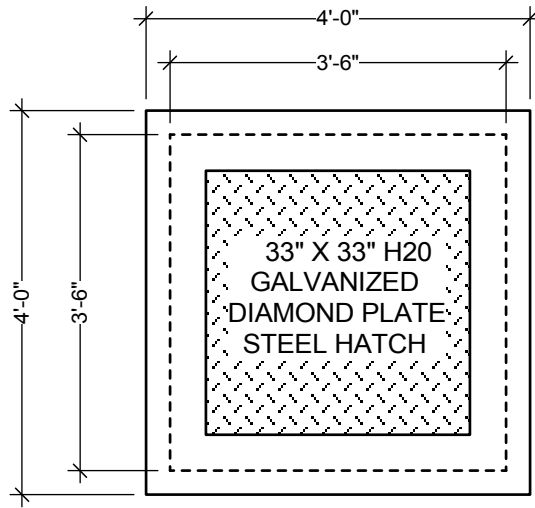

TOP VIEW

Base- Product # 444-B

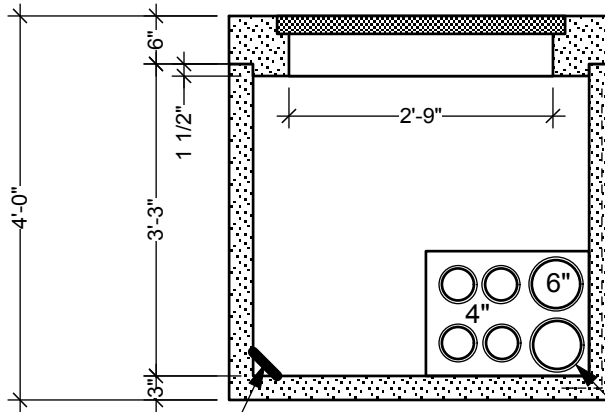

REINFORCEMENT:
 TOP: #3 BAR ALL AROUND
 BASE: 4X4 W5 WW
 WALLS: 6X6 10-GAUGE WW W/ #3 BAR
 IN CORNERS

Galvanized Pulling Bar Typ. All Corners

Duct Terminators
Layout and Size Per
Customer Specs

SECTION VIEW

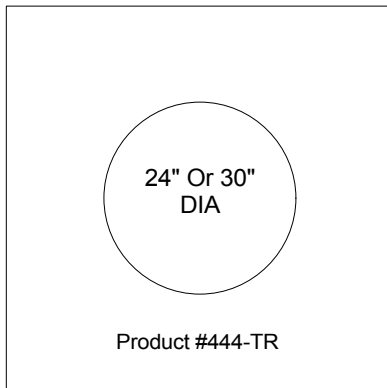

Optional Tops

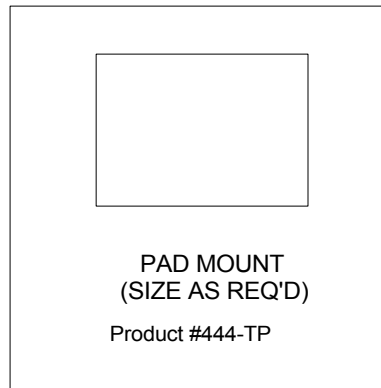

Riser Sections
Available in 1', 2', 3'
and 4' Sections

Scale: 1/2" = 1'-0"

3'6" x 3'6" x 3'3" UTILITY VAULT
 WITH ACCESS HATCH
 PRODUCT #444

WILBERT PRECAST, INC

2215 EAST BROOKLYN - SPOKANE, WASHINGTON 99217

(509) 325-4573

TOLL FREE 1-800-888-4573

FAX (509) 325-5098

SPOKANE - WENATCHEE - LEWISTON - YAKIMA