

**PRODUCT #: 601**  
**WEIGHT #: 1,289 LBS**

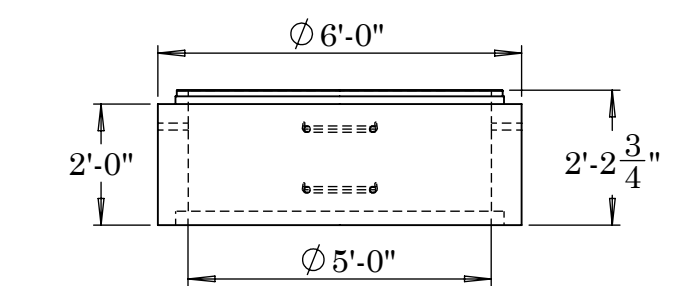

STEPS ADDED  
TO ALL RISERS

**PRODUCT #: 602**  
**WEIGHT #: 2,585 LBS**

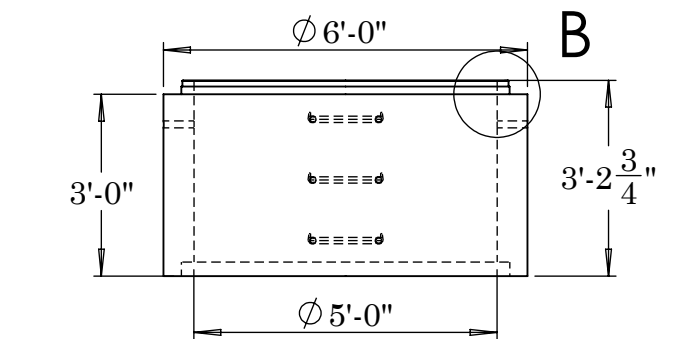

**PRODUCT #: 603**  
**WEIGHT #: 3,880 LBS**

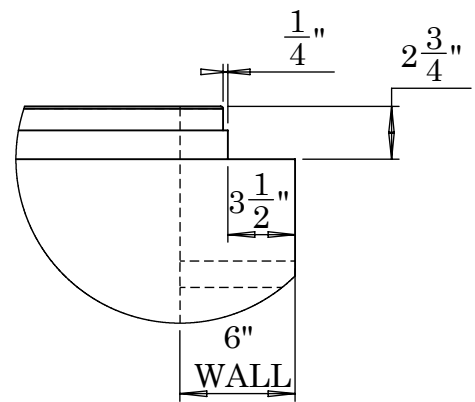

**SHIPLAP DETAIL B**  
**(SAME FOR ALL SIZES)**

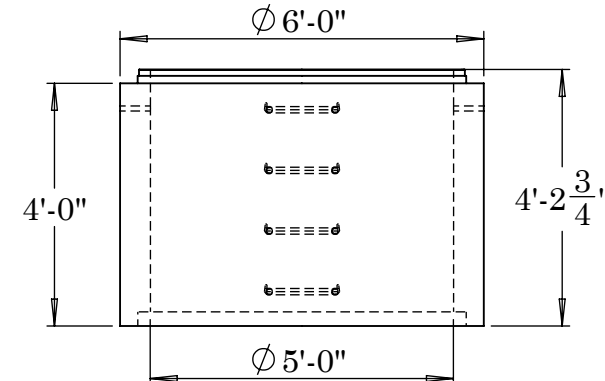

**PRODUCT #: 604**  
**WEIGHT #: 5,176 LBS**

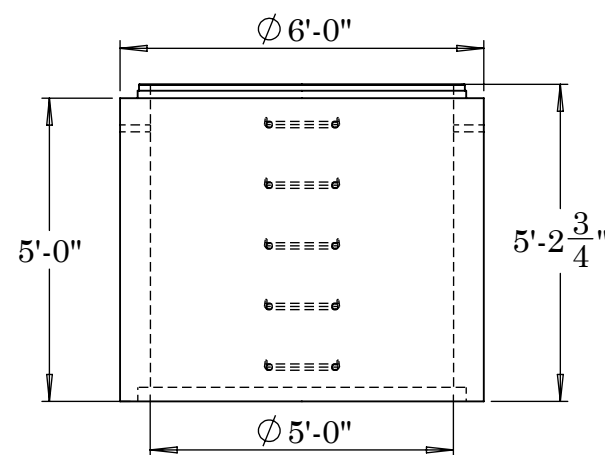

(2) LIFTING HOLES  
ON ALL RISERS

**PRODUCT #: 605**  
**WEIGHT #: 6,471 LBS**

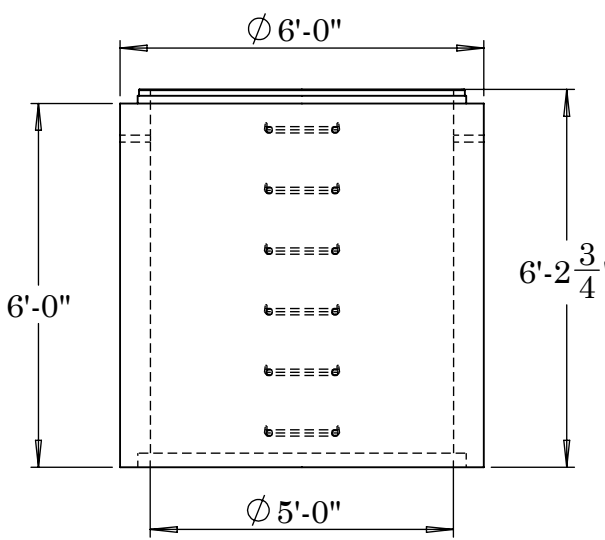

**PRODUCT #: 606**  
**WEIGHT #: 7,766 LBS**

**REINFORCEMENT:**  
-4X8 W4/W1.7 WIRE CAGE THROUGHOUT



**2215 E. BROOKLYN AVE**  
**SPOKANE, WA 99217**  
**TOLL FREE 1-800-888-4573**  
**(509) 325-4573 FAX (509) 325-5098**  
**SPOKANE - LEWISTON - YAKIMA**  
**www.wilbertprecast.com**

**TITLE:** Ø60" MANHOLE RISER PRODUCT SIZES

<b>SIZE</b> <b>B</b>	<b>DWG. NO.</b> Ø60" MH	<b>SCALE:</b> NTS	<b>DATE:</b> 10/17/2025
-------------------------	----------------------------	----------------------	----------------------------

**DRAWN BY:**  
TH