

WARRANTY: ALL TANKS MUST BE BACKFILLED AND COMPACTED PRIOR TO FILLING OR WARRANTY IS VOID.

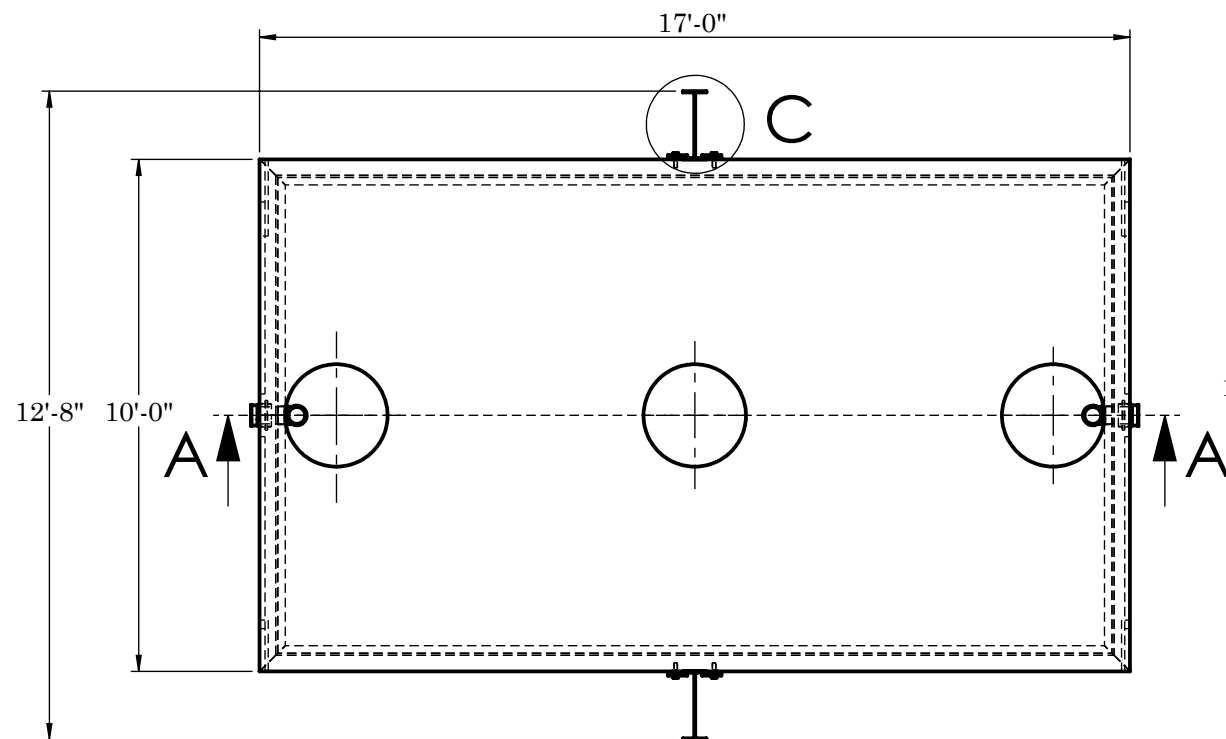

TOP VIEW

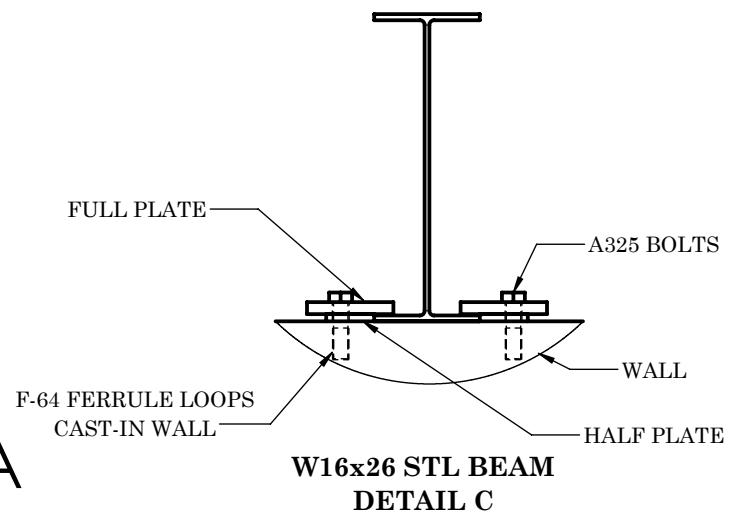

W16x26 STL BEAM DETAIL C

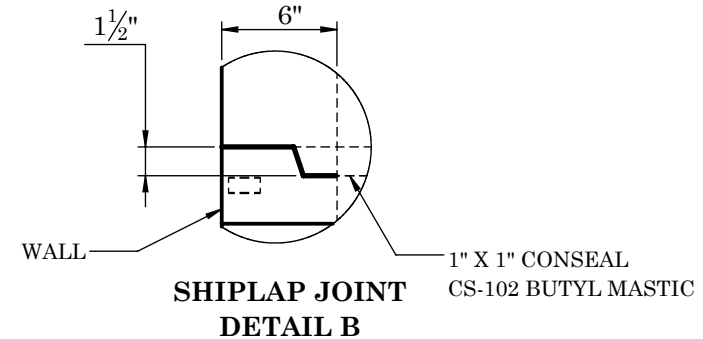

SHIPLAP JOINT DETAIL B

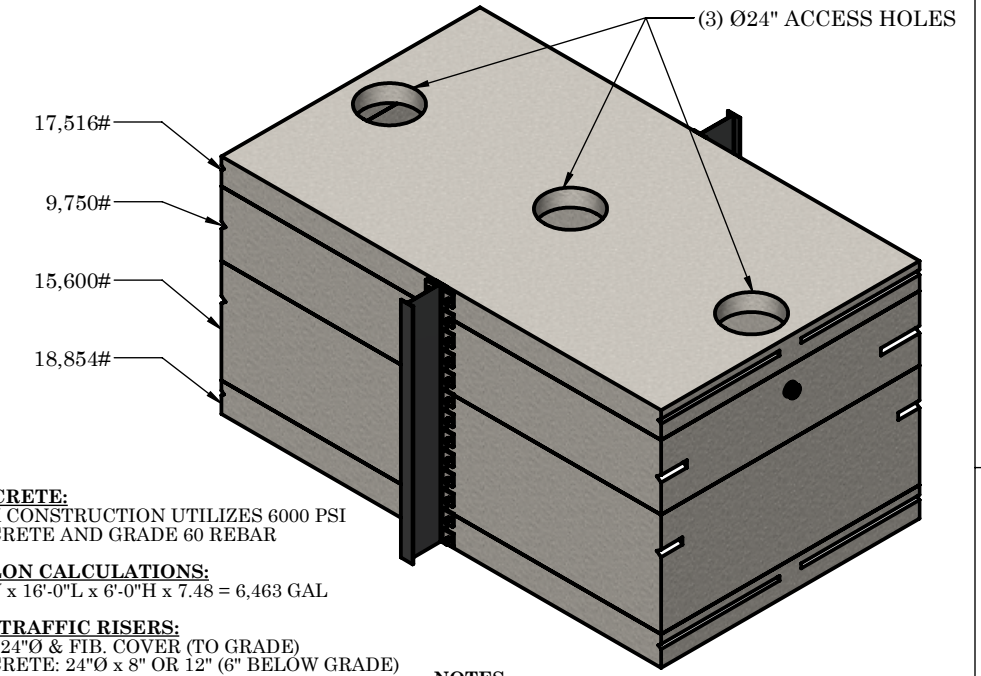

CONCRETE:
TANK CONSTRUCTION UTILIZES 6000 PSI CONCRETE AND GRADE 60 REBAR

GALLON CALCULATIONS:
9'-0"W x 16'-0"L x 6'-0"H x 7.48 = 6,463 GAL

NON-TRAFFIC RISERS:
PVC: 24"Ø & FIB. COVER (TO GRADE)
CONCRETE: 24"Ø x 8" OR 12" (6" BELOW GRADE)

TRAFFIC RISERS/COVERS:
24"Ø GRADE RINGS (2", 3", 4", 5", 6", 13")
4" x 24"Ø CAST-IRON GASKETED BOLT-DOWN

UPLIFT RINGS:
BURY DEPTH WITH WATER AT GRADE ~ 4'
BURY DEPTH WITH WATER AT TOP OF TANK ~ 2'

BEDDING:
4" PEA GRAVEL OR COMPACTED CRUSHED GRAVEL (NO WATER PRESENT)

EXCAVATION:
12" LARGER EACH WAY THAN TANK DIMENSION

BURY:
MAXIMUM BURY DEPTH 5'-0"

- NOTES:**
- 1077 GALLONS/VERTICAL FOOT CAPACITY
 - ON-SITE CRANE SUPPLIED BY CONTRACTOR (20,000# PICK TO CENTER OF EXCAVATION)
 - WIDE FLANGE INSTALLED BY CONTRACTOR. PLATE & BOLT SPACING @ EVERY 8"

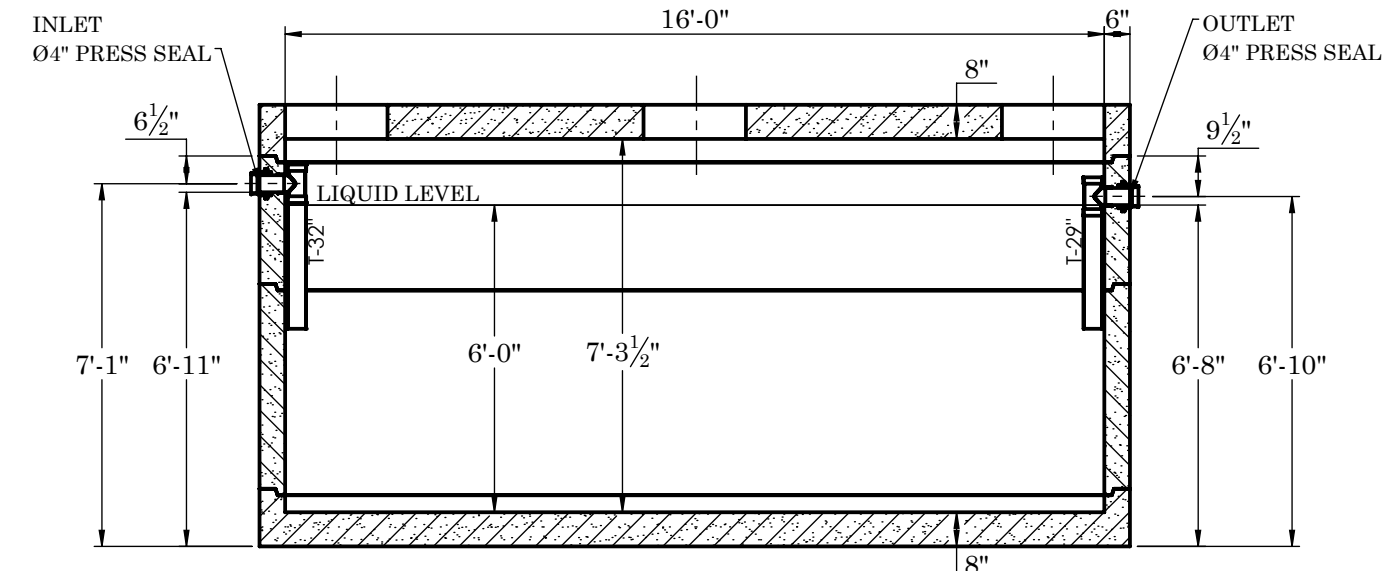

FRONT SECTION VIEW A-A

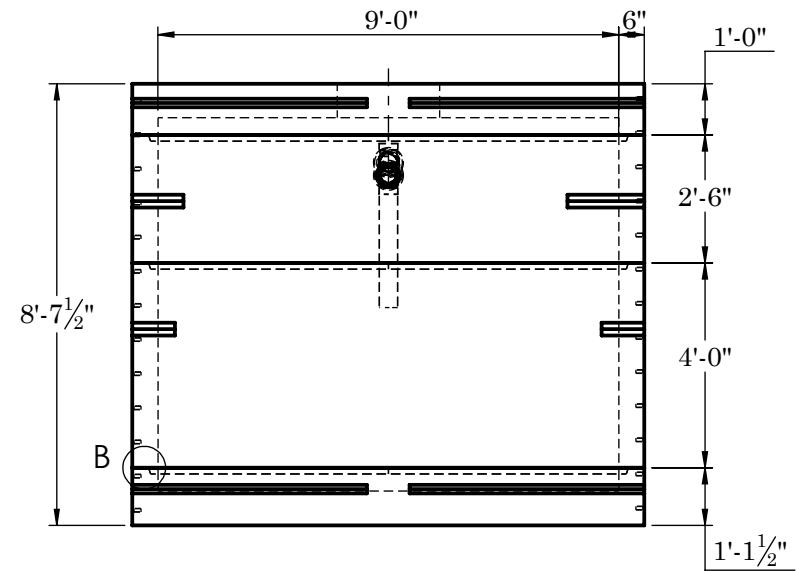

RIGHT VIEW

REINFORCEMENT:

WALLS:
#6 @ 6" O.C. HORIZONTAL
#4 @ 10" O.C. VERTICAL

TOP & BOTTOM
#6 @ 6" O.C. SHORT DIRECTION
#5 @ 12" O.C. LONG DIRECTION, (2) #5 BAR LONG SIDE OF ACCESS, (2) #6 BAR SHORT SIDE



2215 E. BROOKLYN AVE
SPOKANE, WA 99217
TOLL FREE 1-800-888-4573
(509) 325-4573 FAX (509) 325-5098
SPOKANE - LEWISTON - YAKIMA
www.wilbertprecast.com

TITLE:
6000 GALLON SINGLE COMPARTMENT TANK
TRAFFIC BEARING

SIZE B	DWG. NO. 916-6S	SCALE: NTS	DATE: 6/29/2026
-------------------------	---------------------------	----------------------	---------------------------

DRAWN BY:
TH